



Designation: E2218 – 14

## Standard Test Method for Determining Forming Limit Curves<sup>1</sup>

This standard is issued under the fixed designation E2218; the number immediately following the designation indicates the year of original adoption or, in the case of revision, the year of last revision. A number in parentheses indicates the year of last reapproval. A superscript epsilon ( $\epsilon$ ) indicates an editorial change since the last revision or reapproval.

### 1. Scope

1.1 This method gives the procedure for constructing a forming limit curve (FLC) for a metallic sheet material by using a hemispherical deformation punch test and a uniaxial tension test to quantitatively simulate biaxial stretch and deep drawing processes.

1.2 FLCs are useful in evaluating press performance by metal fabrication strain analysis.

1.3 The method applies to metallic sheet from 0.5 mm (0.020 in.) to 3.3 mm (0.130 in.).

1.4 The values stated in SI units are to be regarded as the standard. The inch-pound equivalents are approximate.

1.5 *This standard does not purport to address all of the safety concerns, if any, associated with its use. It is the responsibility of the user of this standard to establish appropriate safety and health practices and determine the applicability of regulatory limitations prior to use.*

### 2. Referenced Documents

2.1 *ASTM Standards:*<sup>2</sup>

A568/A568M Specification for Steel, Sheet, Carbon, Structural, and High-Strength, Low-Alloy, Hot-Rolled and Cold-Rolled, General Requirements for

E6 Terminology Relating to Methods of Mechanical Testing  
E8/E8M Test Methods for Tension Testing of Metallic Materials

E517 Test Method for Plastic Strain Ratio  $r$  for Sheet Metal

E646 Test Method for Tensile Strain-Hardening Exponents ( $n$ -Values) of Metallic Sheet Materials

### 3. Terminology

3.1 Terminology E6 shall apply including the special terms used in this method shown in 3.2.

<sup>1</sup> This method is under the jurisdiction of ASTM Committee E28 on Mechanical Testing and is the direct responsibility of Subcommittee E28.02 on Ductility and Formability.

Current edition approved April 1, 2014. Published June 2014. Originally published in 2002. Last previous edition approved in 2008 as E2218–02(2008). DOI: 10.1520/E2218-14.

<sup>2</sup> For referenced ASTM standards, visit the ASTM website, www.astm.org, or contact ASTM Customer Service at service@astm.org. For *Annual Book of ASTM Standards* volume information, refer to the standard's Document Summary page on the ASTM website.

#### 3.2 Definitions:

3.2.1 *biaxial stretching*—a mode of metal sheet forming in which positive strains are observed in all directions at a given location.

3.2.1.1 *Discussion*—See Fig. 1.

3.2.2 *deep drawing*—a metal sheet forming operation in which strains on the sheet surface are positive in the direction of the punch travel ( $e_1$ ) and negative at 90° to that direction.

3.2.2.1 *Discussion*—Deep drawing, see Fig. 1, occurs in the walls of a drawn cylinder or the corner walls of a deep drawn part when the flange clamping force is sufficient to restrain metal movement and wrinkling, while permitting the punch to push the center area of the blank into the cavity of the die. Strain conditions that can cause wrinkling or thickening are shown in Fig. 2.

3.2.2.2 *Discussion*—In forming a square pan shape, metal from an area of the flange under a reduced clamping force is pulled into the die to form the side wall of the part.

3.2.3 *forming limit diagram (FLD)*—a graph on which the measured major ( $e_1$ ) and associated minor ( $e_2$ ) strain combinations are plotted to develop a forming limit curve.

3.2.3.1 *Discussion*—See Fig. 2.

3.2.4 *forming limit curve (FLC)*—an empirically derived curve showing the biaxial strain levels beyond which localized through-thickness thinning (necking) and subsequent failure occur during the forming of a metallic sheet. See Fig. 3.

3.2.4.1 *Discussion*—The curve of Fig. 3 is considered the forming limit for the material when the metal is subjected to a stamping press operation. It was obtained for a drawing quality aluminum killed steel sheet. The curve of Fig. 3 correlates with the upper curve of Fig. 2, a generic curve representing a metallic sheet material with a  $FLD_0$  of 40 %.

3.2.4.2 *Discussion*—The strains are given in terms of percent major and minor strain measured after forming a series of test specimen blanks by using a grid pattern. The gauge lengths before and after forming the part are measured to obtain the percent strain. The curve for negative ( $e_2$ ) strains will generally follow a constant surface area relationship to the associated ( $e_1$ ) strain.

3.2.4.3 *Discussion*—The range of possible major strain ( $e_1$ ) is from 0 % to over 200 %. The range of possible minor strain ( $e_2$ ) is from –40 % to over +60 %.

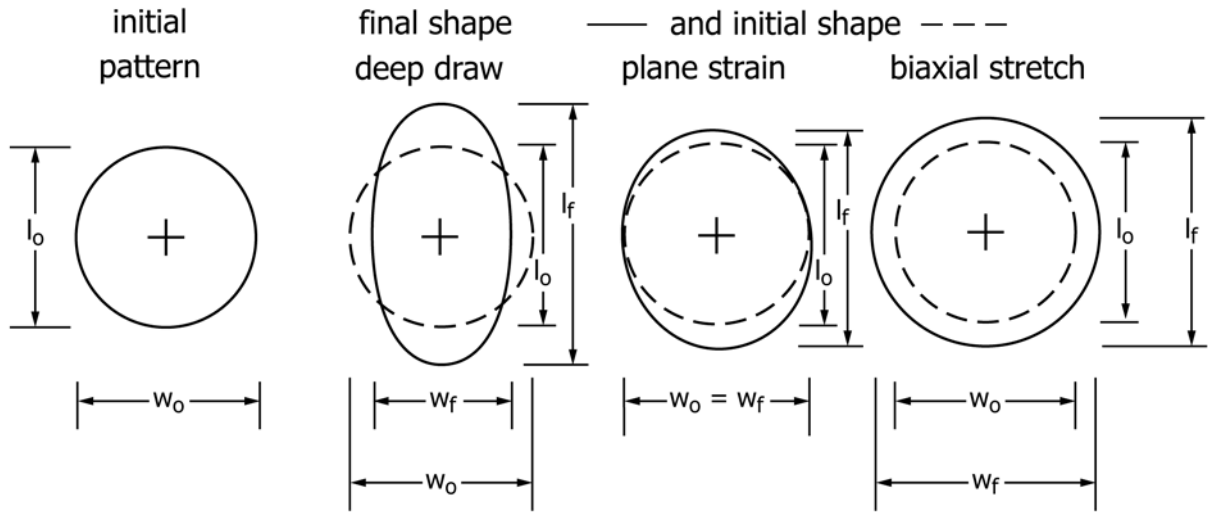
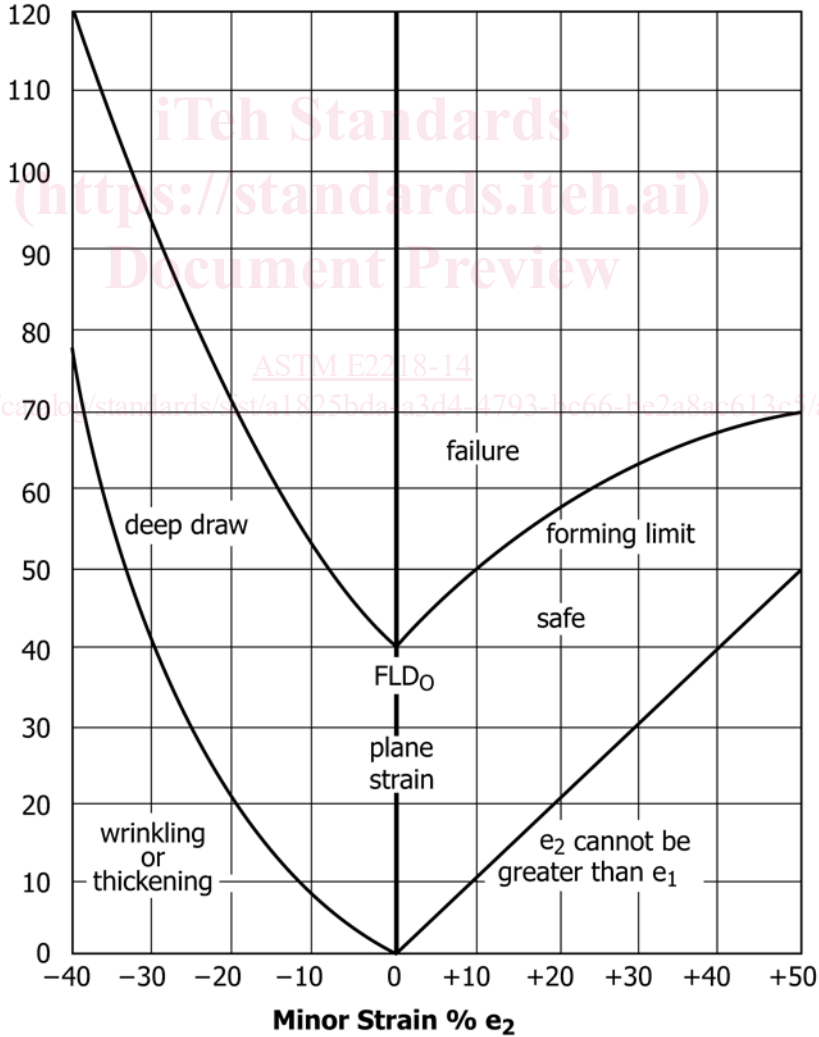

FIG. 1 Possible Changes in Shape of the Grid Pattern Caused by Forming Operations on Metallic Sheet Products

**Major Strain**  
%  $e_1$



NOTE 1—The upper curve is representative of the forming limit. Strains below the lower curve do not occur during forming metallic sheet products in the most stamping press operations. Curves to the left of %  $e_2 = 0$  are for constant area of the sheet surface.

FIG. 2 Forming Limit Diagram

**Major Strain**

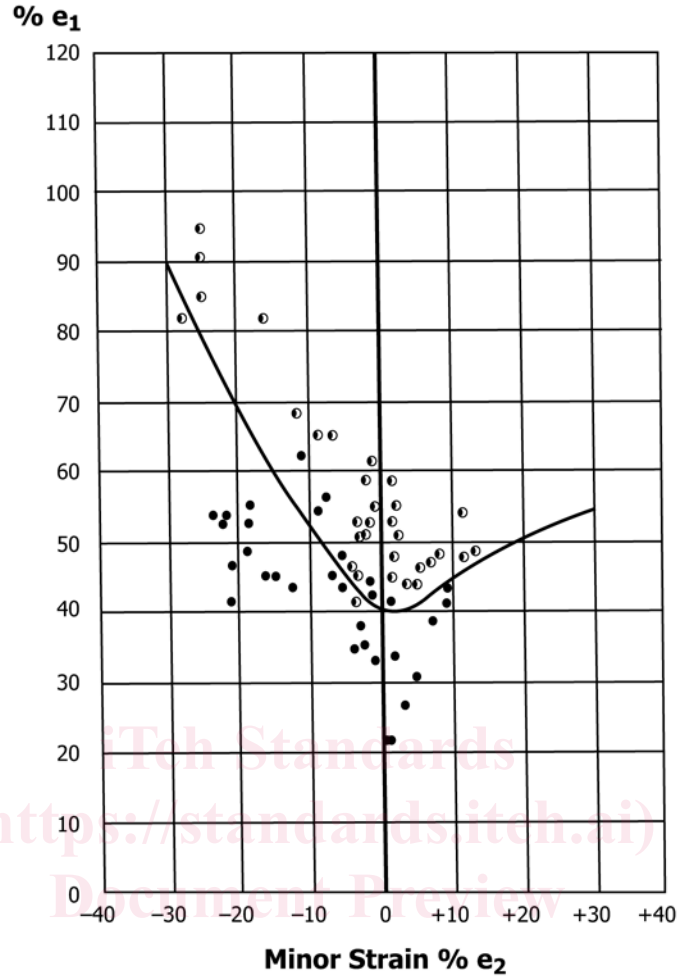

itech Standards  
 (http://standards.iteh.ai)  
 Document Preview

ASTM E2218-14

<https://standards.iteh.ai/catalog/standards/sist/a1825bda-a3d4-4793-bc66-be2a8ac613c5/astm-e2218-14>

Code: ● good ○ Marginal (necked)

**Material properties:**

Thickness 0.866 mm (0.034 in.)  
 Strain hardening (n) 0.230  
 Plastic Strain (r) 1.710

Cold Rolled Drawing Quality Aluminum Killed Steel  
 Longitudinal Mechanical Properties

Thickness		Yield Strength		Tensile Strength		% El in 50 mm	n Value	r Value
mm	(in.)	MPa	(ksi)	MPa	(ksi)			
0.866	(0.034)	163.4	(23.7)	304.7	(44.2)	43.5	0.230	1.71

Chemical Composition

Element Percent	C	S	N	Mn	Al	P	Si
	0.035	0.006	0.006	0.19	0.29	0.006	0.004

**FIG. 3 Forming Limit Curve (FLC) for a Cold Rolled Drawing Quality Aluminum Killed Steel Sheet.**

3.2.5 *limiting dome height (LDH) test*—an evaluative test for metal sheet deformation capability employing a hemispherical punch and a circumferential clamping force sufficient to prevent metal from the surrounding flange being pulled into the die cavity.

3.2.6 *major strain*—the largest strain ( $e_1$ ) developed at a given location in the sheet specimen surface.

3.2.6.1 *Discussion*—The major strain ( $e_1$ ) is measured along the stretched line of a square pattern, or along the major axis of the ellipse resulting from deformation of a circular grid pattern.

3.2.7 *minor strain*—the strain ( $e_2$ ) in the sheet surface in a direction perpendicular to the major strain.

3.2.7.1 *Discussion*—The minor strain ( $e_2$ ) is measured at 90° to the major strain, along the shorter dimension of the final rectangular shape of a part formed using a square pattern, or the shorter axis of the ellipse resulting from deformation of a circular grid pattern. If a square pattern becomes skewed into a parallelogram shape, it shall not be used to measure strain.

3.2.8 *plane strain*—the condition in metal sheet forming that maintains a near zero (0 to +5 %) minor strain ( $e_2$ ) while the major strain ( $e_1$ ) is positive (in tension). It is sometimes referred to as  $FLD_o$ . See Fig. 2 and Fig. 1.

### 3.3 Definitions of Terms Specific to This Standard:

3.3.1 *grid pattern*—a pattern applied to the surface of a metal sheet to provide an array of precisely spaced gauge points prior to forming the metal into a final shape by the application of a force.

3.3.2 *major strain—the largest strain ( $e_1$ )*—developed at a given location in the sheet specimen surface.

3.3.2.1 *Discussion*—The major strain ( $e_1$ ) is measured along the stretched line of a square pattern, or along the major axis of the ellipse resulting from deformation of a circular grid pattern.

3.3.3 *minor strain*—the strain ( $e_2$ ) in the sheet surface in a direction perpendicular to the major strain.

3.3.3.1 *Discussion*—The minor strain ( $e_2$ ) is measured at 90° to the major strain, along the shorter dimension of the final rectangular shape of a part formed using a square pattern, or the shorter axis of the ellipse resulting from deformation of a circular grid pattern.

3.3.4 *plane strain,  $FLD_o$* —the condition in metal sheet forming that maintains a near zero (0 to +5 %) minor strain ( $e_2$ ) while the major strain ( $e_1$ ) is positive (in tension)

3.3.4.1 *Discussion*—Plane strain is the most severe deformation mode and causes a low point in the forming limit curve (FLC). For convenience, many FLCs are shown with the low point at 0 % ( $e_2$ ), however, such an abrupt reversal of ( $e_1$ ) strain does not occur. See Fig. 3 and Figs. X2.1-X2.3.

## 4. Summary of Test Method

4.1 The procedure for determining a forming limit curve (FLC) involves the following:

4.1.1 Using a hemispherical punch testing machine (LDH tester). Sometimes called a bulge tester. The LDH test employs a 100 mm (4 in.) diameter machined surface punch.

4.1.1.1 A universal testing machine for tension load application and a sub-press for against the metal sheet surface

loading with a ball punch of 75 mm (3 in.), 100 mm (4 in.), or larger diameter can be used in place of the LDH test equipment.

4.1.2 Preparing a series of grid pattern blanks with different widths and a common length suitable for being securely gripped in the test apparatus.

4.1.2.1 All specimens for a series shall have their long dimension in the same orientation, relative to the original process rolling direction of the sample and that direction noted in the report.

4.1.3 Lubricating the contact surfaces of the blank and punch for the hemispherical punch test.

4.1.4 Securely clamping the flanges of a blank in the serrated, or lock bead, blank-holder dies of the hemispherical punch test.

4.1.5 Stretching the central area of the blank biaxially over the nose of the hemispherical punch, or pulling in the tension test, without interrupting the force.

4.1.5.1 Negative ( $e_2$ ) strains may be obtained using sheared narrow strips stretched over the punch of the LDH tester.

4.1.6 Stopping the punch advance or the force when a localized through thickness neck (localized necking) is observed, if possible, or as soon as the specimen fractures.

4.1.7 Removing the specimen from the testing machine grips and then proceeding with another, different width, blank in the test series of the same material.

4.1.8 Measuring and recording the ( $e_1$ ) and the ( $e_2$ ) strains of the grid pattern on the surface area near the neck of all the test specimens for the series.

4.1.8.1 These measurements may include good (no localized necking), marginal (localized necking), and fracture areas.

4.1.8.2 If other than good (no localized necking) locations are included, each measured point shall be visually evaluated and noted as illustrated in Fig. 3.

4.1.9 Plotting the measured strain combinations on a  $FLD_o$ . See Fig. 3.

4.1.10 Establishing the forming limit curve (FLC) by connecting the uppermost good (no localized necking) ( $e_1$ ) strains over the associated ( $e_2$ ) strain range used in the study.

4.1.10.1 For practical purposes, the specimens that have been strained to a localized neck-down, or through thickness fracture, condition may be measured at a location on the opposite side of the hemispherical bulge from the fracture, in a good (no localized necking) location, to obtain values to establish the FLC.

4.1.10.2 Another acceptable procedure is to measure the grid near the necked, or fracture, location and identify these data points in determining the forming limit curve. This procedure was used in locating the FLC of Fig. 3.

4.1.10.3 Establishing the FLC depends on judgement. Note that in Fig. 3 there are several good (no localized necking) data points above the FLC and two marginal points below the FLC.

4.1.10.4 The FLC curve shall not include an area where there is a preponderance of marginal data points at an ( $e_1$ ) strain level below the measured good (no localized necking) data points.

## 5. Significance and Use

5.1 A forming limit curve (FLC) defines the maximum (limiting) strain that a given sample of a metallic sheet can undergo for a range of forming conditions, such as deep drawing, stretching and bending over a radius in a press and die drawing operation, without developing a localized zone of thinning (localized necking) that would indicate incipient failure.

5.1.1 FLCs may be obtained empirically by using a laboratory hemispherical punch biaxial stretch test and also a tension test to strain metal sheet specimens from a material sample beyond their elastic limit, just prior to localized necking and fracture.

5.1.1.1 Since this cannot be predetermined, one or both surfaces of specimens are covered with a grid pattern of gauge lengths usually as squares or small diameter circles, by a suitable method such as scribing, photo-grid, or electro-etching, and then each specimen is formed to the point of localized necking, or fracture.

5.1.2 Strains in the major ( $e_1$ ) and minor ( $e_2$ ) directions are measured using points on the grid pattern in the area of the localized necking or fracture.

5.1.2.1 Blanks of varied widths are used to produce a wide range of strain states in the minor ( $e_2$ ) direction.

5.1.2.2 The major ( $e_1$ ) strain is determined by the capacity of the material to be stretched in one direction as simultaneous surface forces either stretch, do not change, or compress, the metal in the ( $e_2$ ) direction.

5.1.2.3 In the tension test deformation process, the ( $e_2$ ) strains are negative and the metal is narrowed both through the thickness and across its width.

5.1.3 These strains are plotted on a forming limit diagram (FLD) and the forming limit curve (FLC) is drawn to connect the highest measured ( $e_1$  and  $e_2$ ) strain combinations that include good data points.

5.1.3.1 When there is intermixing and no clear distinction between good and necked data points, a best fit curve is established to follow the maximum good data points as the FLC.

5.1.4 The forming limit is established at the maximum ( $e_1$ ) strain attained prior to necking.

5.1.5 The FLC defines the limit of useful deformation in forming metallic sheet products.

5.1.6 FLCs are known to change with material (specifically with the mechanical or formability properties developed during the processing operations used in making the material), and the thickness of the sheet sample.

5.1.6.1 The strain hardening exponent ( $n$  value), defined in Test Method E646, affects the forming limit. A high  $n$  value will raise the limiting major strain ( $e_1$ ), allowing more stretch under positive ( $+e_2$ ) strain conditions.

5.1.6.2 The plastic strain ratio ( $r$  value), defined in Test Method E517, affects the capacity of a material to be deep drawn. A high  $r$  value will move the minor ( $-e_2$ ) strain into a less severe area to the left of the  $FLD_0$ , thus permitting deeper draws for a given major ( $e_1$ ) strain.

5.1.6.3 The thickness of the material will affect the FLC since a thicker specimen has more volume to respond to the forming process.

5.1.6.4 The properties of the steel sheet product used in determining the FLC of Fig. 3 included the  $n$  value and the  $r$  value.

5.1.7 FLCs serve as a diagnostic tool for material strain analysis and have been used for evaluations of stamping operations and material selection.

5.1.8 The FLC provides a graphical basis for comparison with strain distributions on parts formed by sequential press operations.

5.1.9 The FLC obtained by this method follows a constant proportional strain path where there is a fixed ratio of major ( $e_1$ ) to minor ( $e_2$ ) strain.

5.1.9.1 There is no interrupted loading, or reversal of straining, but the rate of straining may be slowed as the specimen approaches neck-down, or fracture.

5.1.9.2 The FLC can be used for conservatively predicting the performance of an entire class of material provided the  $n$  value,  $r$  value and thickness of the material used are representative of that class.

5.1.10 Complex forming operations, in which the strain path changes, or the strain is not homogeneous through the metal sheet thickness, may produce limiting strains that do not agree with the forming limit obtained by this method.

5.1.11 Characterization of a material's response to plastic deformation can involve strain to fracture as well as to the onset of necking. These strains are above the FLC.

5.1.12 The FLC is not suitable for lot-to-lot quality assurance testing because it is specific to that sample of a material which is tested to establish the forming limit.

## 6. Apparatus

6.1 Data points for minor strains ( $e_2$ ) near 0 % and for positive strains ( $+e_2$ ) associated with major strains ( $e_1$ ) may be obtained using a hemispherical punch testing machine such as a LDH tester, a sub press in a universal testing machine, or a hydraulic bulge testing machine.

NOTE 1—The LDH test was designed to give a repeatable measure of punch movement among specimens of a specific metal sheet sample; thus the only measured value would be the punch height at incipient fracture. Problems with maintaining a secure clamp result in variation of the measured LDH value. A modification of the LDH test using a strip in the range of 200 mm (8 in.) wide was found to give ( $e_1$ ) values near 0 % ( $e_2$ ), when the surface strains were measured using a grid pattern. On this basis, a test was developed to use a sheared strip of metal sheet 200 mm (8 in.) wide and sufficiently long to be securely clamped in the LDH test fixture. The height at incipient fracture was to correlate with  $FLD_0$ . The test was not sufficiently repeatable to be employed for evaluation of metal sheet samples. The equipment is used to stretch specimens, with grid patterns that have been sheared to various widths and is one method to obtain a range of ( $e_2$ ) and associated ( $e_1$ ) values for plotting a FLC on a FLD.

6.1.1 The hydraulic bulge may employ a liquid or a soft elastic material as the forming force.

6.2 Data points for the negative minor ( $-e_2$ ) strain associated with a major ( $e_1$ ) strain may be obtained using various width strips in a LDH tester and also a universal testing

machine and Test Method E8/E8M for a tension test of a specimen that has a grid pattern on the surface.

6.2.1 A series of specimens having different widths of reduced parallel sections or a series of sheared full length strips with grid patterns may be used to obtain a range of ( $e_2$ ) strains.

6.3 The press apparatus shall be capable of securely clamping the test blank to prevent, or minimize, draw-in of flange metal.

6.3.1 Serrated dies work well with equipment using 75 mm (3 in.), or 100 mm (4 in.) diameter punches. If an interlocking ring bead is used, the fit between the two clamping parts shall be such that no area of the specimen flange is pulled-in by the forming force.

NOTE 2—Restriction of the pull-in of flange metal is not critical in obtaining strips for measuring ( $e_1$ ) and associated ( $e_2$ ) strains to establish the forming limit.

6.3.2 Secure clamping of the flange is critical for the LDH test in which only the punch height is recorded.

6.4 The test system shall have sufficient force and stroke to ensure the hemispherical punch can be driven until the metal sheet ruptures.

6.5 The apparatus shall produce sufficient force to both hold down the flanges and advance the punch to complete the deformation of the blank.

6.6 Although no punch displacement or load measuring capabilities are required for determining data, such devices are helpful in conducting the test.

6.7 The hemispherical punch is advanced against the center of the clamped specimen at a constant rate until the material exhibits localized necking (through thickness thinning) and a fracture appears in the surface of the specimen.

6.7.1 The punch advance may be slowed at the end of the forming process to aid in stopping at the start of localized necking, or when fracture begins.

6.7.2 The nominal punch speed shall be measured and reported.

6.7.3 Unless there is a defect in the material, it should not split across the nose of the punch. Instead, when the punch is advanced beyond the forming limit of the material, necking or fracturing, or both, will occur in a ring encircling the round cap of the formed region.

NOTE 3—Lubrication improves sliding of the material over the surface of the punch and causes rupture to occur closer to the top. This does not

change the forming limit, as the minor ( $e_2$ ) strain adjusts to the increased major ( $e_1$ ) strain.

6.8 The punch shall have a hemispherical nose with a nominal diameter of at least 75 mm (3 in.). Diameters of 100 mm (4 in.) and 200 mm (8 in.) have been used.

6.8.1 The 100 mm (4 in.) diameter limiting dome height (LDH) testing equipment is well suited to straining narrow strips and full size (square, or round) specimen blanks to obtain data for determining the forming limit curve (FLC).

6.8.2 A 75mm (3 in.) round ball seated in a spherical mount can be used as a hemispherical nose punch.

6.9 Clearance between the forming punch and hold down dies shall be large enough to prevent pinching of the metal if the punch advances to full penetration of the die.

6.10 The draw approach radius of the hold down die shall be sufficient to avoid fracture of the test blank in that area during stretching.

6.10.1 Wide blanks may wrinkle or produce an edge tear in the periphery near the hold down bead areas. This is not considered a failure.

6.11 The punch nose and hold down dies shall have a hardness of 50.0 HRC  $\pm$  5.0.

## 7. Materials

### 7.1 Grid Pattern:

7.1.1 An array of squares, or circles, or both, is printed on the surface of the specimen. Suggested patterns are shown in Fig. 4. The pattern shall adhere to the metal so that it will not be moved on the surface or rubbed off by the forming operation. Refer to Specification A568/A568M, Appendix X4—Procedures for Determining the Extent of Plastic Deformation Encountered in Forming or Drawing, for procedures to apply photographic and electrochemically printed grid patterns and a review of strain analysis.

7.1.2 Suggested dimensions for the gauge lengths are 2.5 mm (0.100 in.) for the sides of a square pattern, or diameter of a circle pattern. After the part has been formed, critical areas are measured for the resulting gauge length changes in the long dimension from ( $l_o$ ) to ( $l_f$ ) of the pattern, and in the width dimension ( $w_o$ ) to ( $w_f$ ) at 90° to the long dimension as shown in Fig. 1. The major strain ( $e_1$ ) and associated minor strain ( $e_2$ ) at 90° to ( $e_1$ ) are calculated from these gauge length changes. The strains may be either engineering strain based on the original gauge length, or true strain.

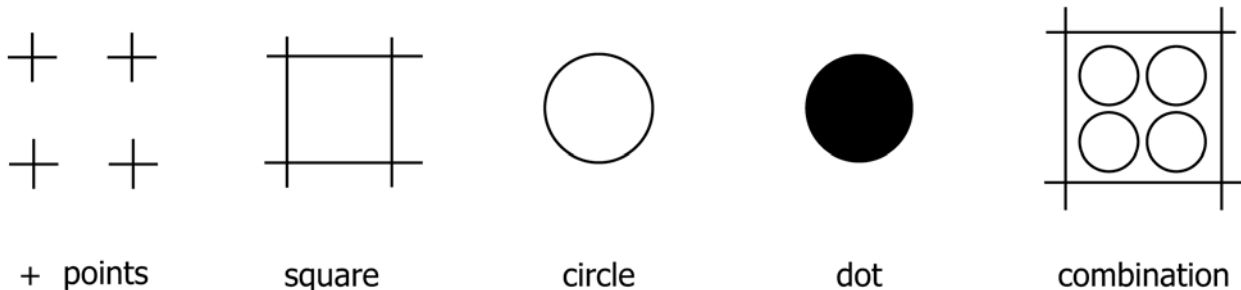

NOTE 1—The basic pattern is repeated over the area of the part to be studied on a flat specimen blank.

FIG. 4 Examples of patterns for Gauge Length measurement units used in Determining Forming Limit Curves (FLC)