



Designation: **F1927–07 F1927 – 14**

## Standard Test Method for Determination of Oxygen Gas Transmission Rate, Permeability and Permeance at Controlled Relative Humidity Through Barrier Materials Using a Coulometric Detector<sup>1</sup>

This standard is issued under the fixed designation F1927; the number immediately following the designation indicates the year of original adoption or, in the case of revision, the year of last revision. A number in parentheses indicates the year of last reapproval. A superscript epsilon ( $\epsilon$ ) indicates an editorial change since the last revision or reapproval.

### 1. Scope

1.1 This test method covers a procedure for determination of the rate of transmission of oxygen gas, at steady-state, at a given temperature and %RH level, through film, sheeting, laminates, co-extrusions, or plastic-coated papers or fabrics. This test method extends the common practice dealing with zero humidity or, at best, an assumed humidity. Humidity plays an important role in the oxygen gas transmission rate ( $O_2$ GTR) of many materials. This test method provides for the determination of oxygen gas transmission rate ( $O_2$ GTR), the permeance of the film to oxygen gas ( $P^{\circ}\Theta(PO_2)$ ), the permeation coefficient of the film to its thickness ( $P\Theta(P''O_2)$ ), and oxygen permeability coefficient ( $P^{\circ}\Theta(P'O_2)$ ) in the case of homogeneous materials at given temperature and %RH level(s).

1.2 The values stated in SI units are to be regarded as the standard.

1.3 *This standard does not purport to address all of the safety concerns, if any, associated with its use. It is the responsibility of the user of this standard to establish appropriate safety and health practices and determine the applicability of regulatory limitations prior to use. Specific precautionary statements are given in Section 9.*

### 2. Referenced Documents

2.1 *ASTM Standards:*<sup>2</sup>

[D1898 Practice for Sampling of Plastics](#) (Withdrawn 1998)<sup>3</sup>

[D3985 Test Method for Oxygen Gas Transmission Rate Through Plastic Film and Sheeting Using a Coulometric Sensor](#)

[E104 Practice for Maintaining Constant Relative Humidity by Means of Aqueous Solutions](#)

[E691 Practice for Conducting an Interlaboratory Study to Determine the Precision of a Test Method](#)

### 3. Terminology

3.1 *Definitions:*

3.1.1 *oxygen permeability coefficient* ( $P^{\circ}\Theta(P'O_2)$ )—the product of the permeance and the thickness of the film. The permeability is meaningful only for homogeneous materials, in which case it is a property characteristic of the bulk material. This quantity should not be used unless the relationship between thickness and permeance has been verified on tests using several different thicknesses of the material. The SI unit of oxygen permeability is the  $\frac{\text{mol}\cdot\text{m}}{\text{m}^2\cdot\text{s}\cdot\text{Pa}\cdot\text{mol}/(\text{m}\cdot\text{s}\cdot\text{Pa})}$ . The test conditions (see [3.1.43.1.4](#)) must be stated.

3.1.2 *oxygen permeance* ( $P^{\circ}\Theta(PO_2)$ )—the ratio of  $O_2$ GTR to the difference between the partial pressure of  $O_2$  on the two sides of the film. The SI unit of permeance is the  $\frac{\text{mol}/\text{m}^2\cdot\text{s}}{\text{Pa}\cdot\text{s}\cdot\text{Pa}}$ . The test conditions (see [3.1.43.1.4](#)) must be stated.

3.1.3 *oxygen permeation coefficient* ( $P\Theta(P''O_2)$ )—the ratio of  $O_2$ GTR to the thickness of the film. The SI unit of permeance is the  $\frac{\text{mol}/\text{m}^2\cdot\text{s}}{\text{cm}\cdot\text{s}\cdot\text{cm}}$ . The permeation coefficient is meaningful only for homogeneous materials, in which case it is a property characteristic of the bulk material. This quantity should not be used unless the relationship between thickness and transmission rate is known.

<sup>1</sup> This test method is under the jurisdiction of ASTM Committee F02 on Flexible Barrier Packaging and is the direct responsibility of Subcommittee F02.10 on Permeation. Current edition approved Aug. 1, 2007 April 1, 2014. Published August 2007 June 2014. Originally approved in 1998. Last previous edition approved in 2004/2007 as F1927–98 (2004) F1927–07. DOI: 10.1520/F1927-07.10.1520/F1927-14.

<sup>2</sup> For referenced ASTM standards, visit the ASTM website, [www.astm.org](http://www.astm.org), or contact ASTM Customer Service at [service@astm.org](mailto:service@astm.org). For *Annual Book of ASTM Standards* volume information, refer to the standard's Document Summary page on the ASTM website.

<sup>3</sup> The last approved version of this historical standard is referenced on [www.astm.org](http://www.astm.org).

3.1.4 *oxygen transmission rate*—at a given temperature and %RH ( $O_2$ GTR), the quantity of oxygen gas passing through a unit area of the parallel surfaces of a plastic film per unit time under the conditions of test. The SI unit of transmission rate is the  $\text{mol}/\text{mmol}/(\text{m}^2 \cdot \text{s} \cdot \text{s})$ . The test conditions, including temperature, %RH and oxygen partial pressure on both sides of the film must be stated.

3.1.5 *transmission rate* ( $O_2$ GTR)—a commonly used metric unit of  $O_2$ GTR is the  $\text{cm}^3$  (STP)/ $\text{m}(\text{STP})/(\text{m}^2 \cdot \text{d} \cdot \text{d})$  at one atmosphere pressure differential where:  $1 \text{ cm}^3$  (STP) is  $44.62 \text{ } \mu\text{mol}$ ,  $1 \text{ atm}$  is  $0.1013 \text{ MPa}$ , at Standard Temperature and Pressure (STP =  $273.15\text{K}$ ;  $1.013 \times 10^5 \text{ Pa}$ ) is  $44.62 \text{ } \mu\text{mol}$  and one day is  $86.4 \times 10^3 \text{ s}$ .  $O_2$ GTR in SI units is obtained by multiplying the value in metric units by  $5.165 \times 10^{-10}$  or the value in inch-pound units [ $(\text{cm}^3/\text{STP}/100(\text{STP})/100 \text{ in.}^2 \cdot \text{d})$ ] by  $8.005 \times 10^{-9}$ .

#### 4. Summary of Test Method

4.1 The oxygen gas transmission rate is determined after the sample has equilibrated in a given temperature and humidity environment.

4.2 The specimen is mounted as a sealed semi-barrier between two chambers at ambient atmospheric pressure. One chamber is slowly purged by a stream of nitrogen at a given temperature and %RH and the other chamber is purged by a stream of oxygen at the same temperature as the  $N_2$  stream but may have a different %RH than the  $N_2$  stream. In this case the environment would more closely simulate actual shelf conditions. As oxygen gas permeates through the film into the nitrogen carrier gas, it is transported to the coulometric detector where it produces an electrical current, the magnitude of which is proportional to the amount of oxygen flowing into the detector per unit time.

#### 5. Significance and Use

5.1  $O_2$ GTR at a given temperature and %RH is an important determinant of the packaging protection afforded by barrier materials. It is not, however the sole determinant, and additional tests, based on experience, must be used to correlate packaging performance with  $O_2$ GTR. It is suitable as a referee method of testing, provided that purchaser and seller have agreed on sampling procedures, standardization procedures, test conditions and acceptance criteria.

#### 6. Interferences

6.1 The presence of certain interfering substances in the carrier gas stream may give rise to unwanted electrical outputs and error factors. Interfering substances include free chlorine and some strong oxidizing agents. Exposure to carbon dioxide should also be minimized to avoid damage to the sensor through reaction with the potassium hydroxide electrolyte.

#### 7. Apparatus

7.1 *Oxygen Gas Transmission Apparatus*, as diagramed in [Fig. 1](#) and described following. Alternative systems need to be evaluated to ensure equivalent performance.

7.1.1 *Diffusion Cell*, consisting of two metal halves, that, when closed upon the test specimen, will accurately define a circular area. Typical acceptable diffusion cell areas are  $100$  and  $50 \text{ cm}^2$ . The volume enclosed by each cell half, when clamped, is not critical: it should be small enough to allow for rapid gas exchange, but not so small that an unsupported film which happens to sag or bulge will contact the sides of the cell. The diffusion cell shall be provided with a temperature measuring and controlling capability and a means to measure and control relative humidity.

7.1.1.1 Temperature control is critical because RH can vary as much as  $5 \text{ \% RH}/^\circ\text{C}$  in certain temperature regions. A compact design of the diffusion cell structure with associated controls would lend itself to better temperature control. The temperature should be controlled to  $\pm 0.5^\circ\text{C}$  or better.

7.1.1.2 *O-Ring*—An appropriately sized groove, machined into the oxygen (or test gas) side of the diffusion cell, retains a neoprene O-ring. The test area is considered to be that area established by the inside contact diameter of the compressed O-ring when the diffusion cell is clamped shut against the test specimen. The area,  $A$ , can be obtained by measuring the inside diameter of the imprint left by the O-ring on the specimen after it has been removed from the diffusion cell.

7.1.1.3 The nitrogen (or carrier gas) side of the diffusion cell shall have a flat raised rim. Since this rim is a critical sealing surface against which the test specimen is pressed, it shall be smooth and flat, without radial scratches.

7.1.1.4 *Diffusion Cell Pneumatic Fittings*—Each half of the diffusion cell shall incorporate suitable fittings for the introduction and exhaust of gasses without significant loss or leakage.

7.1.1.5 Experience has shown that arrangements using multiple diffusion cells are a practical way to increase the number of measurements which can be obtained from a coulometric sensor. A valving manifold shall connect the carrier gas side of each individual diffusion cell to the sensor in a preselected pattern. Carrier gas is continually purging the carrier gas sides of those cells that are not connected to the sensor. Either test gas or carrier gas, as is appropriate, purges the test gas chamber of any individual cell.

7.1.2 *Catalyst Bed*—Should be used on the carrier gas ( $N_2$ ) side of the diffusion cell assembly to provide an essentially oxygen free carrier gas. Palladium catalyst on alumina converts  $O_2$  molecules into  $H_2O$ , thus virtually eliminating  $O_2$  molecules in the carrier gas.

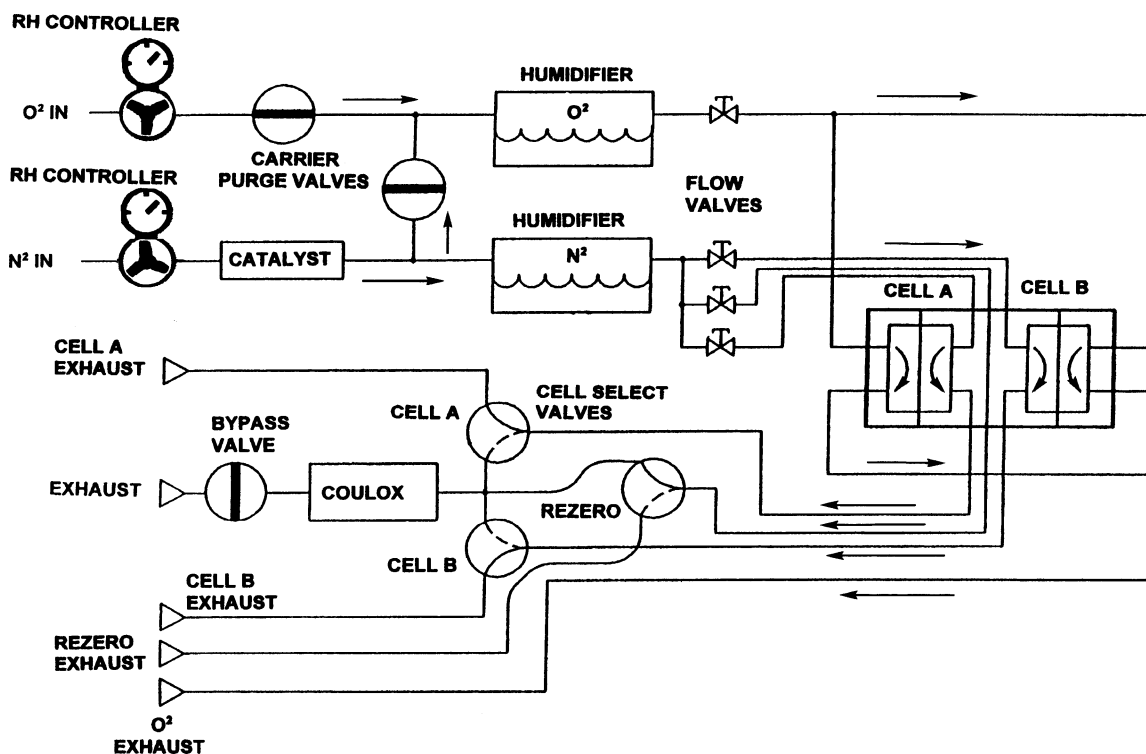

FIG. 1 A Practical Arrangement of Components for the Measurement of Oxygen Transmission Rate Under Precise Relative Humidity Conditions Using the Coulometric Method

7.1.3 Oxygen gas transmission apparatus shall have the capability of measuring, at a variety of relative levels including, zero RH to 90 % RH at a wide range of temperatures.

7.1.4 Package testing at given temperature and %RH levels to be optional if it is not included in the basic configuration.

7.1.5 *Coulometric Sensor*—An oxygen-sensitive coulometric sensor operating at an essentially constant efficiency shall be used to monitor the quantity of oxygen transmitted.

7.1.6 With computer controlled systems, the results are printed out giving final results, time-history of equilibration, ambient conditions of test, material being tested and date. Should a failure occur, the time of this occurrence and its cause and correction taken should be documented for operator analysis as to the validity of continued testing.

7.1.7 *RH Detectors*—Water sensitive solid-state devices are used to monitor the relative humidity of the gases directly in the upper and lower halves of the cell.

7.1.7.1 Placement of the RH detectors in the diffusion cells is important because relative humidity will change whenever the temperature of the relative humidity source and diffusion cells differ.

7.1.7.2 The RH detectors should periodically be calibrated against saturated salt solutions (see Practice E104) or NIST traceable devices.<sup>4</sup>

## 8. Reagents and Materials

8.1 *Nitrogen Carrier Gas*, consisting of a nitrogen and hydrogen mixture in which the percentage of hydrogen shall fall between 0.5 and 3.0 volume %. The carrier gas shall be dry and contain not more than 100 ppm of oxygen. A commercially available mixture known as “forming gas” is suitable.

8.2 *Oxygen Test Gas*, shall be dry and contain not less than 99.5 % oxygen (except as provided in 14.10).

8.3 *Water to Generate %RH*—Double or triple-distilled water is recommended (not deionized water) for precise relative humidity generation and to avoid scale build up.

8.4 *Sealing Grease*—A high-viscosity hydrocarbon grease<sup>5</sup> (preferred) or a high-vacuum grease is required for sealing the specimen film in the diffusion cell.

<sup>4</sup> Hasegawa, S. (NIST) “National Basis of Accuracy in Humidity Measurements,” *ISA Transactions*, Vol 25, No. 3, 1986, pp. 15–24.

<sup>5</sup> The sole source of supply of the apparatus, a suitable hydrocarbon grease such as Apiezon T-T is known to the committee at this time is, Biddle Instruments, 510 Township Road, Blue Bell, PA 19422-time. If you are aware of alternative suppliers, please provide this information to ASTM Headquarters. Your comments will receive careful consideration at a meeting of the responsible technical committee that you may attend.