



Designation: ~~C1242 – 12a~~^{ε1} C1242 – 14

Standard Guide for Selection, Design, and Installation of Dimension Stone Attachment Systems¹

This standard is issued under the fixed designation C1242; the number immediately following the designation indicates the year of original adoption or, in the case of revision, the year of last revision. A number in parentheses indicates the year of last reapproval. A superscript epsilon (ϵ) indicates an editorial change since the last revision or reapproval.

~~ε¹ NOTE—Sections 5 through 9 were editorially reordered to follow a logical sequence in April 2013.~~

INTRODUCTION

Natural building stone is chosen as a building's cladding for its beauty which endures with minimal maintenance. Stone is durable when used properly. Exercising good judgment when selecting the particular stone, determining the quarrying and fabrication techniques, designing the method of attachment, and installing all components correctly maximizes these benefits. A properly executed stone cladding is designed and installed within the capabilities and limitations of the stone and support system to resist all forces that work on them.

This guide presents design principles that require consideration when designing anchorages and evaluating exterior stone to be compatible with its proposed use. It is an overview of current techniques and a review of minimum requirements for sound stone engineering and construction. The guide does not list all possible methods of attachment nor does it provide a step-by-step procedure for stone anchor engineering. Knowledge gained from new engineering designs, testing of applications, and the investigation of existing problems are continually reviewed to update this guide. Comment from users is encouraged.

Good judgment by architects, engineers, and contractors when specifying, designing, engineering, and constructing stone and other work that interfaces stone is necessary to use this guide. Users of this guide should combine known performance characteristics of the stone, the building's structural behavior, and knowledge of materials and construction methods with proven engineering practice.

1. Scope

1.1 This guide covers the categories of anchors and anchoring systems and discusses the design principles to be considered in selecting anchors or systems that will resist gravity loads and applied loads.

1.2 This guide sets forth basic requirements for the design of stone anchorage and provides a practical checklist of those design considerations.

1.3 This guide pertains to:

1.3.1 The anchoring of stone panels directly to the building structure for support,

1.3.2 The anchoring of stone panels to subframes or to curtainwall components after these support systems are attached to the building structure,

1.3.3 The anchoring of stone panels to subframes or to curtainwall components with stone cladding preassembled before these support systems are attached to the building structure, and

1.3.4 The supervision and inspection of fabrication and installation of the above.

1.4 Observe all applicable regulations, specific recommendations of the manufacturers, and standards governing interfacing work.

1.5 The values stated in inch-pound units are to be regarded as standard. The values given in parentheses are mathematical conversions to SI units that are provided for information only and are not considered standard.

¹ This guide is under the jurisdiction of ASTM Committee C18 on Dimension Stone and is the direct responsibility of Subcommittee C18.06 on Attachment Components and Systems.

Current edition approved ~~June 15, 2012~~ May 1, 2014. Published ~~July 2012~~ June 2014. Originally approved in 1993. Last previous edition approved in 2012 as ~~C1242 – 12~~ C1242 – 12a^{ε1}. DOI: ~~10.1520/C1242-12AEO1~~ 10.1520/C1242-14.

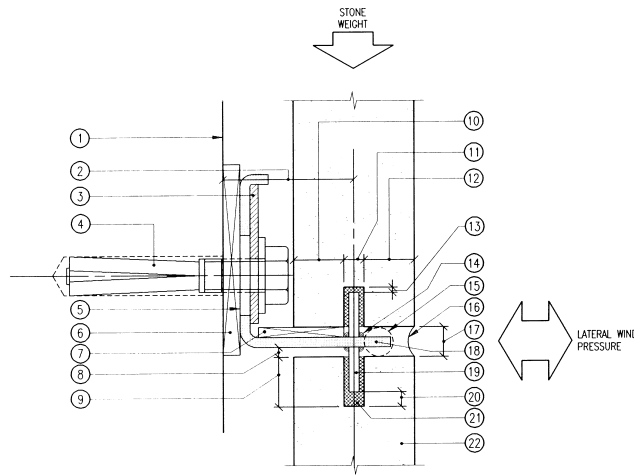

ANCHOR IN HORIZONTAL JOINT CAN SUPPORT GRAVITY AND LATERAL LOADS (FIGURE AS SECTION VIEW)
 ANCHOR IN VERTICAL JOINT CAN SUPPORT ONLY LATERAL LOADS (FIGURE AS PLAN VIEW)

- | | |
|---|---|
| <p>① SUPPORT ANCHORAGE ON COMPATIBLE, STABLE BACKUP.</p> <p>② MINIMIZE DISTANCE TO MINIMIZE ECCENTRIC WEIGHT ON ANCHORAGE AND TO REDUCE FASTENER (PART 4) PULLOUT AND SUPPORT ANGLE (PART 17) DISPLACEMENT. ALLOW FOR FABRICATION, CONSTRUCTION AND INSTALLATION TOLERANCES.</p> <p>③ PREVENT SLIP OF THE CONNECTION AFTER VERTICAL ADJUSTMENT WITH DIAGONALLY SLOTTED WASHER PLATE, WELD WASHER WITH WELD, OR SERRATED ANCHOR AND WASHER. DO NOT RELY ON FRICTION.</p> <p>④ ATTACH ANCHOR WITH FASTENER TO BACKUP.</p> <p>⑤ USE HORIZONTAL SLOT TO ALIGN DOWEL WITH HOLE. VERTICAL SLOT TO ALLOW FOR HEIGHT ADJUSTMENT AND FASTENER PLACEMENT.</p> <p>⑥ PLACE PLASTIC OR METAL ADJUSTMENT BEARING SHIM SLIGHTLY LARGER THAN ANCHOR'S FASTENED FACE. REQUIRED TO SEPARATE AND ADJUST POSITION OF ANCHOR RELATIVE TO FRAMING. MINIMIZE THICKNESS TO MINIMIZE BENDING ON FASTENER (PART 4). THICKNESS AFFECTS FASTENER (PART 4) CAPACITY.</p> <p>⑦ PLACE PLASTIC OR STIFF RUBBER BEARING SHIM FOR LEVELING, SEPARATION, AND TO PREVENT BEARING OF STONE ON DOWEL WELD. ADJUST ANCHOR VERTICALLY WITH PART 3, NOT SHIMS.</p> <p>⑧ MAINTAIN CLEARANCE TO AVOID CONTACT AND WEIGHT TRANSFER (UNLESS DESIGNED TO STACK). ALLOW FOR MOVEMENT, CREEP, EXPANSION, AND FABRICATION AND INSTALLATION TOLERANCES.</p> <p>⑨ MINIMIZE HOLE DEPTH. INCLUDING VARIANCES PER PART 20, MAINTAIN 3/8 IN. (10mm) ENGAGEMENT OR TESTED MINIMUM GREATER ENGAGEMENT DOES NOT NECESSARILY INCREASE ANCHOR CAPACITY.</p> <p>⑩ VERIFY INTERIOR EDGE DISTANCE. STONE HERE RESISTS NEGATIVE (OUTWARD AND SUCTION) PRESSURE. MAINTAIN SUFFICIENT WIDTH FROM MINIMUM PANEL THICKNESS.</p> <p>⑪ LOCATE HOLE IN CENTER THIRD OF PANEL THICKNESS. MINIMIZE DIAMETER TO MAXIMIZE EDGE DISTANCE (PARTS 10 AND 12).</p> | <p>⑫ VERIFY EXTERIOR EDGE DISTANCE. STONE HERE RESISTS POSITIVE (INWARD) PRESSURE. KEEP THIS DIMENSION CONSTANT FROM OUTSIDE FACE TO KEEP PANEL FACES ALIGNED.</p> <p>⑬ MAINTAIN CLEARANCE TO AVOID POINT LOADING ON DOWEL END. DIMENSION TO EQUAL OR EXCEED PART 7.</p> <p>⑭ WELD AT FIXED DOWEL. MINIMUM DIAMETER HOLE ONLY FOR CLEARANCE AT DROP (LOOSE) DOWEL.</p> <p>⑮ BOND BREAKER AT ANCHOR AND BACKER ROD BEYOND TO PREVENT THREE SIDED SEALANT BOND.</p> <p>⑯ FILL JOINTS BETWEEN PANELS WITH COMPRESSIBLE GASKET OR SEALANT WITH PROPER PROFILE AND COMPATIBILITY.</p> <p>⑰ SIZE JOINTS TO ALLOW FOR HARDWARE, TOLERANCES, CLEARANCES, APPROPRIATE MOVEMENT, AND JOINT FILLER CAPABILITY. ISOLATE DYNAMIC BUILDING MOVEMENTS FROM THIS TYPE OF ANCHOR.</p> <p>⑱ CONNECT DOWEL TO BACKUP WITH METAL LATERAL AND GRAVITY SUPPORT ANGLE (BRAKE-FORMED SHAPED SHOWN). CAN ALSO BE ROLLED OR EXTRUDED SHAPE.</p> <p>⑲ ENGAGE PANEL EDGE WITH A FIXED OR DROP (LOOSE) METAL DOWEL. AVOID DOWEL MISALIGNMENT IN HOLE AND RESULTING PRYING ON STONE PANEL.</p> <p>⑳ MAINTAIN CLEARANCE TO AVOID POINT LOADING ON DOWEL ENDS. DIMENSION TO EQUAL OR EXCEED PART 8. DO NOT ALLOW FLOOR-TO-FLOOR MOVEMENTS TO OCCUR IN THE HOLES.</p> <p>㉑ FILL HOLES WITH COMPRESSIBLE MATERIAL TO PREVENT MOISTURE ACCUMULATION, TO FIX POSITION, AND TO CUSHION BEARING OF DOWEL ON SIDES OF HOLE. WAX, GREASE, WRAP TAPE ON DOWEL OR BED A SLEEVE FOR THE DOWEL TO SLIDE ON WHERE ADHESION IS NOT DESIRED.</p> <p>㉒ DIMENSION STONE CLADDING FACE PANEL.</p> |
|---|---|

FIG. 1 Dowel Anchor

1.6 This standard does not purport to address all of the safety concerns, if any, associated with its use. It is the responsibility of the user of this standard to establish appropriate safety and health practices and determine the applicability of regulatory limitations prior to use. (See Tables 1 and 2.)

2. Referenced Documents

2.1 ASTM Standards:²

- C97 Test Methods for Absorption and Bulk Specific Gravity of Dimension Stone
- C99 Test Method for Modulus of Rupture of Dimension Stone
- C119 Terminology Relating to Dimension Stone
- C170 Test Method for Compressive Strength of Dimension Stone
- C406 Specification for Roofing Slate
- C482 Test Method for Bond Strength of Ceramic Tile to Portland Cement Paste
- C503 Specification for Marble Dimension Stone
- C509 Specification for Elastomeric Cellular Preformed Gasket and Sealing Material
- C568 Specification for Limestone Dimension Stone
- C615 Specification for Granite Dimension Stone

² For referenced ASTM standards, visit the ASTM website, www.astm.org, or contact ASTM Customer Service at service@astm.org. For Annual Book of ASTM Standards volume information, refer to the standard's Document Summary page on the ASTM website.

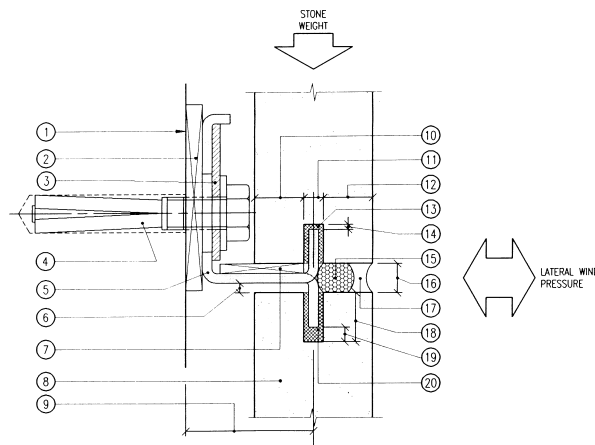

ANCHOR IN HORIZONTAL JOINT CAN SUPPORT GRAVITY AND LATERAL LOADS (FIGURE AS SECTION VIEW)
 ANCHOR IN VERTICAL JOINT CAN SUPPORT ONLY LATERAL LOADS (FIGURE AS PLAN VIEW)

- | | |
|--|---|
| <ul style="list-style-type: none"> ① SUPPORT ANCHORAGE ON COMPATIBLE, STABLE BACKUP. ② PLACE PLASTIC OR METAL ADJUSTMENT BEARING SHIM SLIGHTLY LARGER THAN ANCHOR'S FASTENED FACE. REQUIRED TO SEPARATE DISSIMILAR MATERIALS AND ADJUST TO FRAMING. MINIMIZE THICKNESS TO MINIMIZE BENDING ON FASTENER (PART 4). ③ PREVENT SLIP OF THE CONNECTION AFTER VERTICAL ADJUSTMENT WITH DIAGONALLY SLOTTED WASHER PLATE, WELD WASHER WITH WELD, OR SERRATED ANCHOR AND WASHER. DO NOT RELY ON FRICTION. ④ ATTACH ANCHOR WITH FASTENER TO BACKUP. ⑤ KERF ANCHOR (BRAKE-FORMED SPLIT-EAR SHAPE SHOWN) OR EXTRUDED SHAPE THAT FITS INTO SAWN KERF. AVOID MISALIGNMENT AND RESULTING PRYING ON KERF FROM INACCURATE FABRICATION OR INSTALLATION. SHOULD NOT BE CONTINUOUS ACROSS PANEL JOINTS. CAPACITY OF CONNECTION IS NOT DIRECTLY PROPORTIONAL TO ANCHOR LENGTH. ⑥ MAINTAIN CLEARANCE TO AVOID CONTACT AND WEIGHT TRANSFER (UNLESS DESIGNED TO STACK). ALLOW FOR MOVEMENT, CREEP, EXPANSION, AND FABRICATION AND INSTALLATION TOLERANCES. ⑦ PLACE PLASTIC OR STIFF RUBBER BEARING SHIM FOR LEVELING, SEPARATION, AND TO PREVENT BEARING OF STONE KERF FIN ON ANCHOR RADIUS. ADJUST ANCHOR VERTICALLY WITH PART 3, NOT SHIMS. ⑧ DIMENSION STONE CLADDING FACE PANEL. ⑨ MINIMIZE DISTANCE TO MINIMIZE ECCENTRIC WEIGHT ON ANCHOR - REDUCES FASTENER (PART 4) PULLOUT AND SUPPORT ANCHOR (PART 5) DISPLACEMENT. ⑩ VERIFY INTERIOR KERF FIN. STONE HERE RESISTS NEGATIVE (OUTWARD OR SUCTION) PRESSURE. MAINTAIN SUFFICIENT WIDTH FROM MINIMUM PANEL THICKNESS. | <ul style="list-style-type: none"> ⑪ LOCATE CONTINUOUS OR INTERMITTENT SAWCUT KERF IN CENTER THIRD OF THICKNESS. CONTROL WIDTH TO ALLOW TOLERANCE WITH KERF ANCHOR. MINIMIZE WIDTH TO MAXIMIZE EDGE DISTANCES (PARTS 10 AND 12). ⑫ VERIFY EXTERIOR KERF FIN (3/8 IN. (10mm) MINIMUM) STONE HERE RESISTS POSITIVE (INWARD) PRESSURE. KEEP THIS DIMENSION CONSTANT TO KEEP STONE FACES ALIGNED. ⑬ FILL KERF IN BOTTOM EDGE OF STONE ONLY AT ANCHORS WITH SEALANT TO SET POSITION AND TO CUSHION BEARING. ⑭ MAINTAIN CLEARANCE TO AVOID POINT LOADING AT TOP AND BOTTOM. DIMENSION TO EQUAL OR EXCEED PART 6. DO NOT ALLOW FLOOR-TO-FLOOR MOVEMENTS TO OCCUR IN THE KERF. ⑮ PLACE BACKER ROD OR FOAM TAPE AT PROPER DEPTH TO PREVENT THREE-SIDED SEALANT BOND. ⑯ SIZE JOINTS TO ALLOW FOR HARDWARE, TOLERANCES, CLEARANCES, APPROPRIATE MOVEMENT, AND JOINT FILLER CAPABILITY. ISOLATE DYNAMIC BUILDING MOVEMENTS FROM THIS TYPE OF ANCHOR. ⑰ FILL JOINTS BETWEEN PANELS WITH COMPRESSIBLE GASKET OR SEALANT WITH PROPER PROFILE AND COMPATIBILITY. ⑱ MINIMIZE KERF DEPTH TO MINIMIZE PRYING AND MAXIMIZE CAPACITY. MAINTAIN 3/8 IN. (10mm) MINIMUM OR TESTED MINIMUM ENGAGEMENT. ⑲ MAINTAIN CLEARANCE TO AVOID POINT LOADING AT KERF IN TOP OF STONE. DIMENSION TO EQUAL OR EXCEED PART 6. DO NOT ALLOW DYNAMIC DISPLACEMENTS TO OCCUR IN THE KERF. ⑳ FILL KERF IN TOP EDGE OF STONE CONTINUOUSLY WITH SEALANT TO TOP OF KERF TO PREVENT MOISTURE ACCUMULATION, SET POSITION, AND CUSHION BEARING OF ANCHOR ON SIDES OF KERF. |
|--|---|

FIG. 2 Kerf Anchor

[C616 Specification for Quartz-Based Dimension Stone](#)

[C629 Specification for Slate Dimension Stone](#)

[C864 Specification for Dense Elastomeric Compression Seal Gaskets, Setting Blocks, and Spacers](#)

[C880 Test Method for Flexural Strength of Dimension Stone](#)

[C1115 Specification for Dense Elastomeric Silicone Rubber Gaskets and Accessories](#)

[C1193 Guide for Use of Joint Sealants](#)

[C1201 Test Method for Structural Performance of Exterior Dimension Stone Cladding Systems by Uniform Static Air Pressure Difference](#)

[C1354 Test Method for Strength of Individual Stone Anchorages in Dimension Stone](#)

[C1496 Guide for Assessment and Maintenance of Exterior Dimension Stone Masonry Walls and Facades](#)

[C1526 Specification for Serpentine Dimension Stone](#)

[C1527 Specification for Travertine Dimension Stone](#)

[E632 Practice for Developing Accelerated Tests to Aid Prediction of the Service Life of Building Components and Materials](#)

3. Terminology

3.1 *General Definitions*—For definitions of terms used in this guide, refer to Terminology [C119](#).

3.2 Specific definitions used in the design process are listed in [7.4](#).

4. Significance and Use

4.1 This guide is intended to be used by architects, engineers, and contractors who either design or install exterior stone cladding for architectural structures.

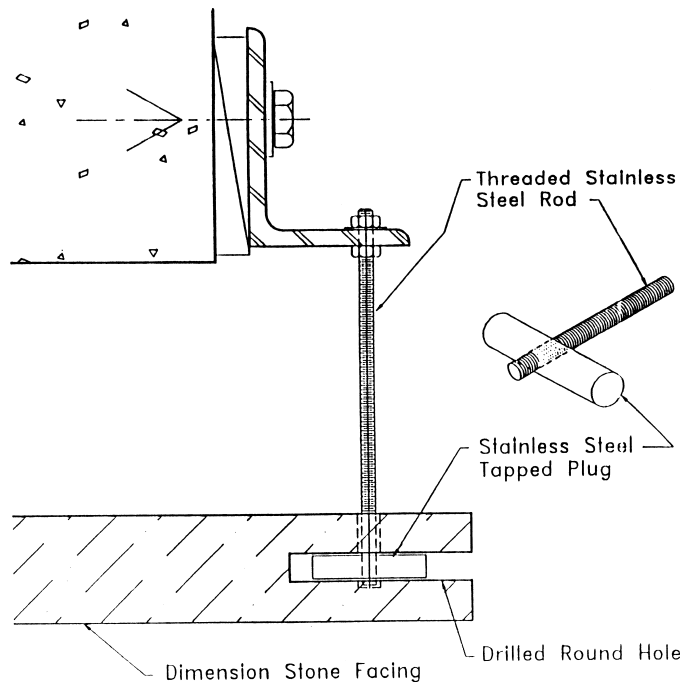

FIG. 3 Rod and Plug Anchor

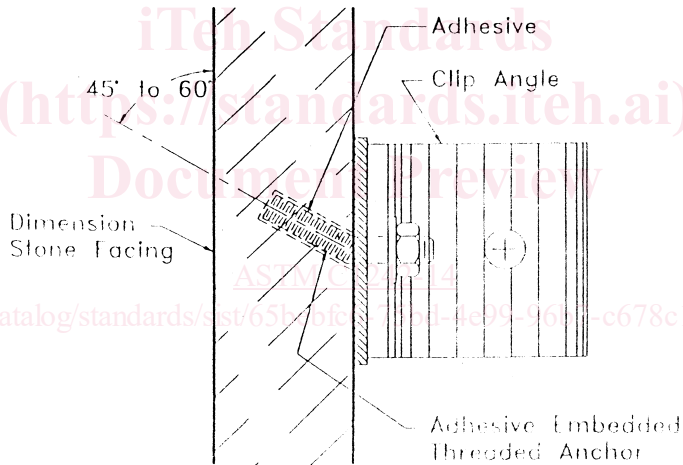

FIG. 4 Adhesive Embedded Threaded Anchor

4.2 This guide is an industry standard for engineering design considerations, documentation, material considerations, anchor type applications, and installation workmanship to assist designers and installers to achieve a proper and durable stone cladding.

4.3 Stone and its support systems are part of a building's skin and shall be compatible with the behavior and performance of other interfacing systems, such as the curtainwall and superstructure frame.

4.3.1 Every stone work application shall comply with applicable building codes.

4.3.2 It is not the intent of this Guide to supercede published recommendations for specific stone types. Provisions of other dimension stone industry publications should be reviewed and considered in addition to this Guide's recommendations. All industry information should be considered with respect to project specifications and requirements. If provisions of such publications differ from those in this Guide, it is acceptable practice to follow the publication's provisions if recommended by the stone specialist defined in 4.4 for the specific conditions of the individual project.

4.3.3 Because stone properties vary, the range and variability of pertinent properties of the stone proposed for use should be determined by testing and statistical methods that are evaluated using sound engineering principles. Use recent test data where applicable. Always reference proven performance of relevant existing structures.

4.3.4 Changes in properties over time shall be considered.

4.3.5 Overall behaviors of all building systems and components including the stone shall be interactively compatible.

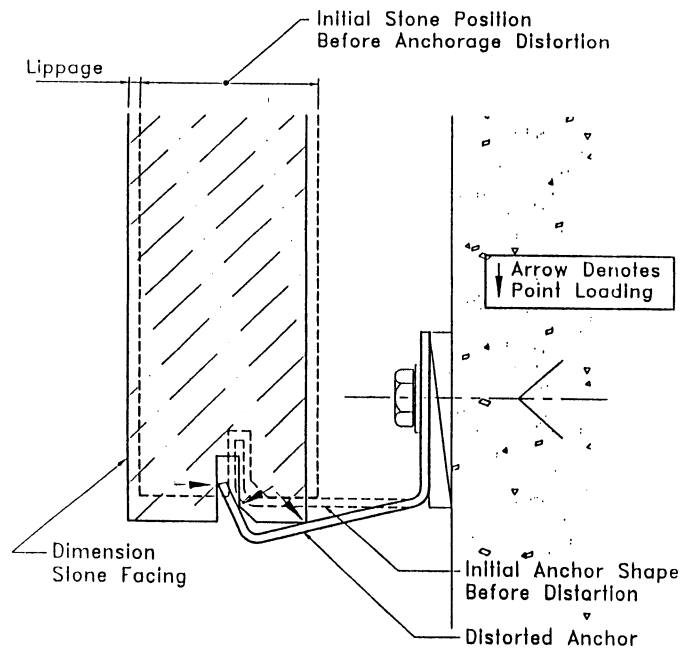

FIG. 5 Point Loading Prevention

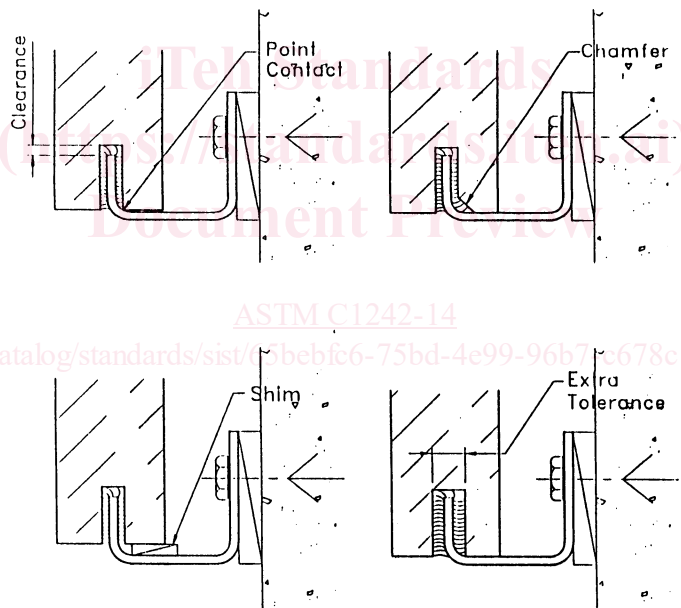

FIG. 5 Point Loading Prevention (continued)

4.4 *Stone Specialist*—Some conditions require professional expertise to select and plan a proper anchoring system, establish appropriate testing requirements, interpret tests, design and engineer the anchoring system, or monitor its fabrication and installation. A specialist is a person that complements the capabilities of the project team by contributing specific expert experience with the use, selection, design, and installation of dimension stone.

4.4.1 Particular conditions where special expertise is suggested to achieve a reliable installation:

- 4.4.1.1 Where complex connections or anchoring methods of unknown or questionable performance records are likely to be considered or specified;
- 4.4.1.2 Where the performance record of the specified systems and materials is not known or questionable;
- 4.4.1.3 When multiple cladding materials occur on the same facade;
- 4.4.1.4 If the supporting structure or backup is more flexible than $L/600$ in any direction;
- 4.4.1.5 If extreme loading could be caused by seismic, hurricane, tornado, or installation and handling methods;
- 4.4.1.6 When special building code requirements prevail.
- 4.4.1.7 If provisions of stone industry publications or project specifications differ from this guide.

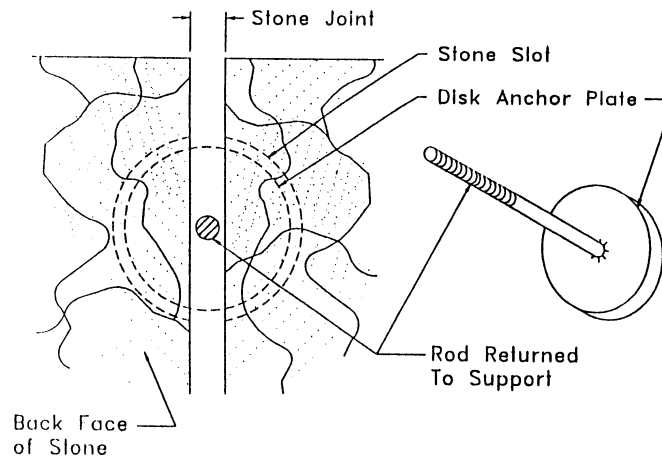

FIG. 6 Disc Anchor

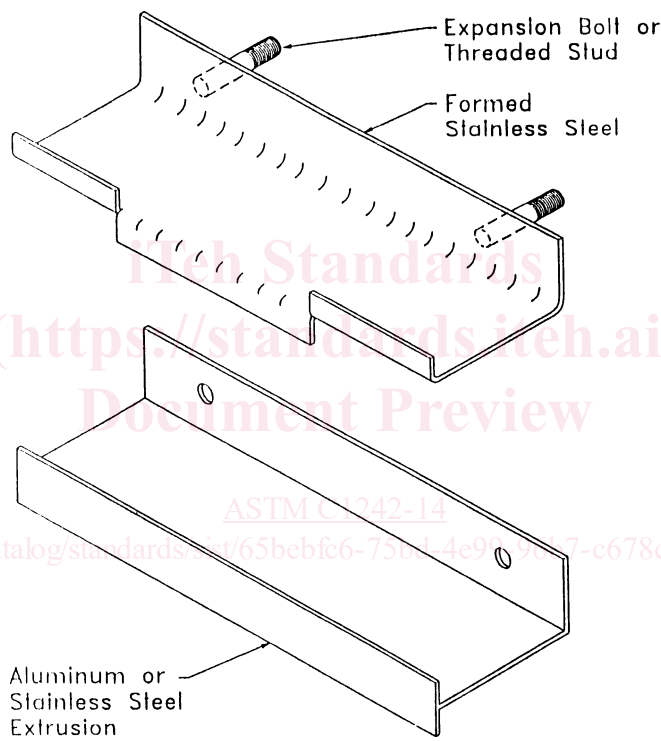

FIG. 7 Combined Anchor

5. Selection Considerations

5.1 Review the following factors before selecting a stone material, an anchoring system and subframe system from those options being considered:

5.1.1 Have the stone materials under consideration performed well on existing buildings in similar exposures?

5.1.2 Have the different anchoring and subframe systems under consideration performed well on existing buildings in similar exposures?

5.1.3 How is the performance of the anchor and its engagement into the stone affected by installation and handling procedures?

5.1.4 How are the performance and appearance of the subframe, the anchor's connection to the subframe, and the subframe's connections to the building structure affected by differential movements?

5.1.5 Do the physical characteristics of the stone measured by standard tests show the material has structural limitations? Which physical properties are important to the application, and which test methods measure those properties and their variability? Refer to [Table 2](#) for standard test methods and properties they measure.

TABLE 1 Dimension Stone Specifications

Stone Type	ASTM Specification
Calcite ^A	C503
Dolomite ^A	C503
Granite	C615
Limestone ^B	C568
Marble (exterior) ^B	C503
Quartz-Based ^B	C616
Quartzite ^A	C616
Quartzitic Sandstone ^A	C616
Sandstone ^A	C616
Serpentine ^A	C503
Serpentine	C1526
Slate (roof)	C406
Slate (walls)	C629
Travertine ^A	C1527

^A This stone type is a subclassification.

^B This stone type has subclassifications or grades.

TABLE 2 Dimension Stone Test Methods

Measures	ASTM Test Method
liquid porosity and relative density	C97
combined shear with tensile unit strength from bending	C99
ultimate crushing unit strength	C170
primary tensile unit strength from bending	C880
capacity and deflections of panels assembled with their anchors onto their supporting backup structure	C1201
individual anchor strength	C1354
accelerated production of service life	E632

5.1.6 Do the physical characteristics of the stone not measured by standard tests suggest the material may have long-term durability concerns? Other properties, including (but not limited to) resistance to chemical attack, weather-related strength reduction, and dimensional changes, might be evaluated by special laboratory tests designed to obtain data under simulated conditions.

5.1.7 Does the project location or shape develop exceptional design wind, or seismic loads, or does the stone material require higher safety factors than other stones not anticipated by statutory codes?

5.1.8 Do the anchor and subframe system accommodate building dimensional changes caused by wind and seismic sway, thermal and elastic deformation, creep and shrinkage, and their combined effects?

5.1.9 Will contiguous facade elements such as windows, other claddings, window supports, or window-washing and wall maintenance provisions influence the stone cladding, its anchoring or subframe system?

5.1.10 Do the anchor or subframe systems penetrate waterproofing, facilitate internal moisture collection, or penetrate wall insulation and cavity ventilation?

5.1.11 Do the materials used resist corrosion, galvanic and chemical reactions?

5.2 The following general rules are helpful in the design of anchors and connections:

5.2.1 The simplest connections are usually the best.

5.2.2 Make connections with the fewest components.

5.2.3 Use the fewest possible anchor connection types in any particular project.

5.2.4 Provide for adjustability in connections to accommodate tolerances in materials and construction.

5.2.5 Distribute the weight of stone or panel systems on no more than two points of connection where possible.

5.2.6 Make anchor connection locations accessible to the craftsman.

5.2.7 Design connection components and stone sinkages to avoid entrapping moisture.

5.2.8 At friction connections with slotted holes parallel to the direction of load, specify proper bolts, washers, slot size, and bolt installation procedure.

5.3 *Safety Factors*—In order to design an anchoring system, the variabilities of the materials being considered should be known and compensated. This is accomplished through the use of an appropriate safety factor to be applied to the stone, the anchorage, and the backup structure.

5.3.1 **Table 3** shows generally accepted Safety Factors for stone cladding by stone type. These factors are recognized by industry specialists and publications and are based upon past successful practice. These factors are based on a maximum coefficient of variation of 20 % when project samples are tested in accordance with Test Methods C99 or C880 for sedimentary stones in thicknesses of 2 in. (50 mm) or greater. Safety factors could be changed when conditions listed under 5.3.2 or 5.3.3 exist in the project.

TABLE 3 Generally Accepted Safety Factors for Stone Cladding by Stone Type

Stone Type	Specification	Safety Factor
granite	C615	3
limestone	C568	6
group A marble	C503	5
travertine	C1527	8
sandstone	C616	6
slate	C629	5

5.3.2 *Exemplar Availability:* A safety factor could be modified if the long-term performance of the stone material, anchor and backup system cannot be verified by well-performing exemplars. Consult a stone specialist as defined in 4.4 for the appropriate change in safety factor.

5.3.3 *Structural Variables:* A safety factor could be modified if specific conditions exist on the project different from those upon which Table 3 values are based. Consult a stone specialist as defined in 4.4 for the appropriate change in safety factor. Some specific conditions are:

- 5.3.3.1 Critical material strength tests show increased variability;
- 5.3.3.2 Life expectancy of project exceeds forty years;
- 5.3.3.3 Stone material loses significant strength over time;
- 5.3.3.4 When designing stone at anchors;
- 5.3.3.5 Anchor capacity tests show increased variability;
- 5.3.3.6 Anchors will not be inspected in final position on building;
- 5.3.3.7 Anchors require varied installation techniques or varied positions;
- 5.3.3.8 Panel is used in higher-risk position such as a soffit, overhang, liner block, assembled on backup before being erected or other similar position.

6. Anchor Types

6.1 *Precast Anchors (see Fig. 8):*

6.1.1 Smooth dowels, wire hairpins (preformed wire spring-type anchors), threaded rods or bolts are used as anchors to attach stone cladding to precast concrete panels. Adhesives compatible with the stone may be used in conjunction with such anchors. However, relying solely on adhesives to support stone is not recommended.

6.1.1.1 The number of dowels is determined by analysis and testing.

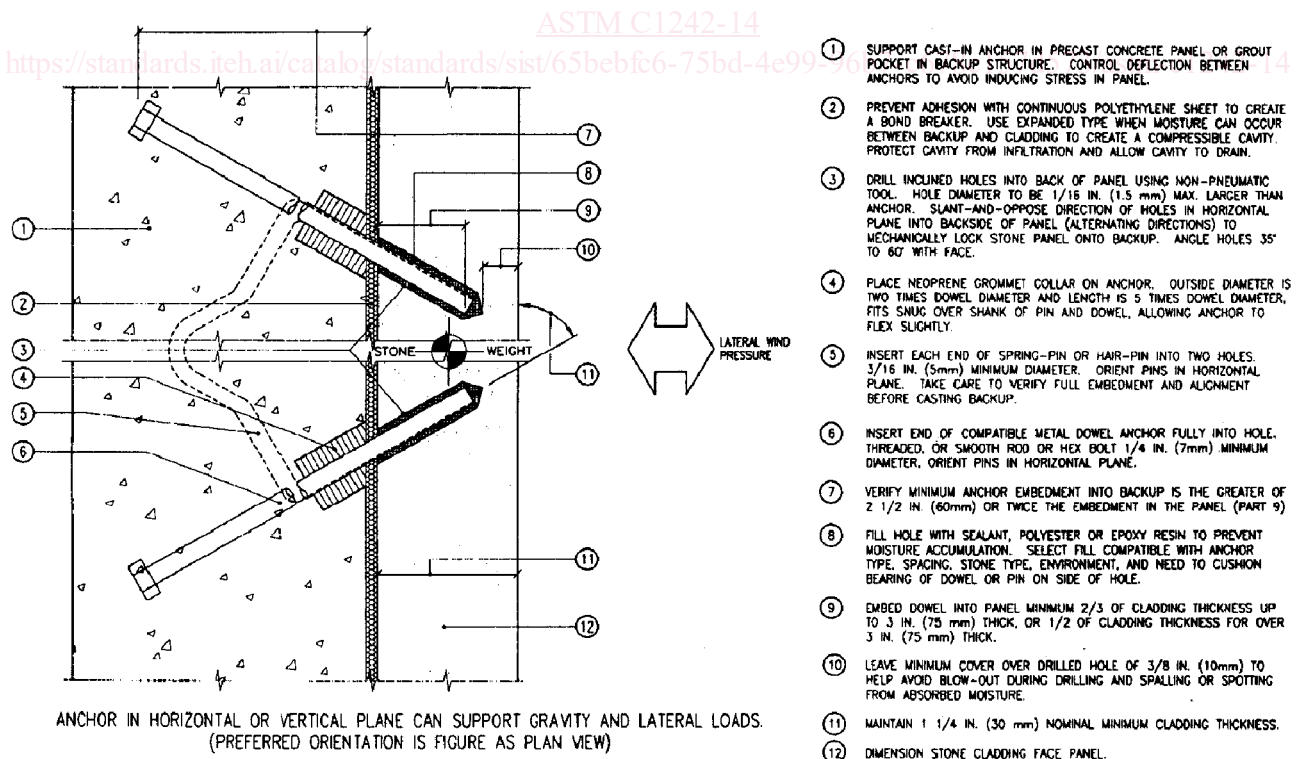

FIG. 8 Cast-In Anchors

6.1.1.2 The dowels anchor the cladding to the concrete backup. The angle of the dowel to the stone is usually 45°, angled into the precast, with the patterns opposing each other within the same stone. The holes for the dowels should be jig-drilled with diamond core bits. (See Fig. 8.)

6.1.1.3 The dowel embedment in to the stone should be a minimum of two-thirds of the thickness of the stone. The bottom of the dowel hole should not be closer than 3/8 in. (9.5 mm) to the face of the stone. The embedded section of the dowel into the precast concrete backup should not be less than 2 1/2 in. (64 mm).

6.1.1.4 All dowels should be within the limits of the concrete reinforcing cage when viewed in elevation.

6.1.1.5 The recommended minimum diameter of dowels is 3/16 in. (4.8 mm).

6.1.2 Number of anchors should be a minimum of two per individual panel and should follow the general rules of 5.2. Use Test Method C1354 anchor testing or panel bending analysis to determine number of anchors required.

6.1.2.1 The anchor embedment into the back of the stone is usually 3/4 in. (19.1 mm) deep. Two opposing holes are drilled into the back of the stone at an angle of 45° to the plane of the back. These holes are either angled toward or away from each other, depending upon the configuration of the hairpin anchor. The straight legs of the anchor are inserted into the holes, the shape of the anchor acting to keep the legs engaged. The recommended minimum distance between the bottom of the anchor hole and the finished face of the stone is 3/8 in. (9.5 mm). (See Fig. 8.)

6.1.3 The precast panel must be stiffer than the stone panel so that it will deform less than the stone panel under the same load conditions.

6.1.3.1 No strength value is assigned or considered between the cladding stone and the concrete backup. A bond breaker should be provided between the stone cladding and the precast backup.

6.1.4 Anchors should angle into the back of the stone between 45 and 30°, without pointing downward when the panel is in its final installed position. Separate anchors in the same panel should point in opposite directions to lock cladding onto precast. Orient anchors perpendicular to gravity load whenever possible. Particular care should be taken when anchoring soffit stones to ensure that all anchors are splayed and effectively resist vertical and lateral loads.

6.2 Wire Ties (see Fig. 9):

6.2.1 Wire ties used on vertical panels are intended to resist only lateral loads. Weight of vertical panels should be supported by bearing on a ledge, corbel, slot, shelf, or liner separate from the ties.

6.2.2 Wire ties with portland-cement based mortar spots can be used to attach stone cladding to cast-in-place concrete or masonry backup on exteriors. Wire ties with gypsum or molding plaster spots can be used to attach interior stone panels to backup.

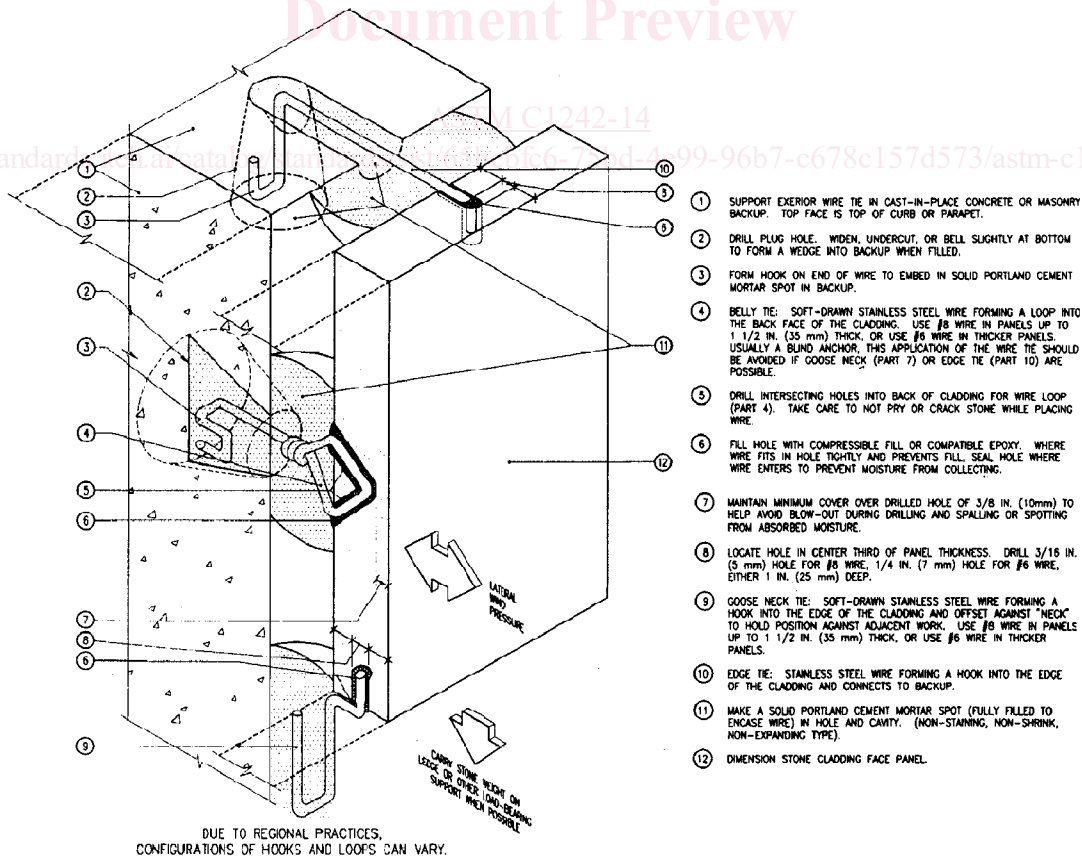

FIG. 9 Wire Ties

6.2.3 Some stones are stained by mortar or plaster spots. Verify compatibility of spot, tie and stone materials before installing to avoid staining. Also verify that wire ties can be used in the intended application.

6.2.4 Wire ties can hook into the edge of a panel or wrap through intersecting holes drilled into the side, or back of the stone, or both. Looping wire ties through intersecting holes in the back of the stone allows anchors to remain hidden. Wire ties should hook into or mechanically fasten into the backup to act as a tensile tie to the stone. The spot needs to be tight between the backup and the stone to provide for compression transfer. Fill anchor holes with portland-cement based mortar or epoxy. Plaster may be used on interior applications to hold wire firmly in stone. Set stone and clamp in place until spots cure.

6.2.5 Number of wires should be minimum of two and a maximum of four per individual panel and should follow the general rules of 5.2. If Test Method C1354 anchor testing or panel bending showed more than four anchors were required, then the backup must be made stiffer than the stone panel.

6.2.6 Drill holes following guidelines of 6.1.4. Tie embedment into stone, depth of holes and edge distances should follow the guidelines of 6.1.2.1.

6.2.7 Minimum recommended wire diameter is 0.148 in. (4 mm) for exterior, 0.0808 in. (2 mm) for interior.

6.3 *Face Anchors*—Face anchors are basically through-bolted fasteners. Their main use currently is corrective in nature, as a reinforcement for stone experiencing anchor failure, although it has some potential as a decorative feature. In this use, a decorative plate or washer is exposed at the exterior face of the stone with a bolt either passing through this washer or welded to it. A backup plate or washer should also be used at the back of stone to transfer lateral loads to the through-bolt. The bolt is then passed through the backup wall and secured with a nut at the opposite face of the wall. The load is adequately distributed by a plate or the bolt is anchored into the backup structure.

6.4 *Blind Anchors*—Blind anchors are those not available for visual examination during and after anchorage installation and should not be used unless no other options exist.

6.5 *Liners*—Liners are pieces of stone or metal attached to the back of the stone. Their function is to transfer loads from the stone to an anchor. Connections between the liners and stone are through a mechanical connection. An adhesive bond is used only to facilitate attachment of the liner to the stone. The mechanical connection should consist of two or more stainless steel fasteners per liner, set at a 30 or 45° angle both upward and downward from the back of the liner into the stone. The fasteners are installed after the liner adhesive has set. Liners can have a reglet cut into them to form a kerf to receive an anchor or can be square cut. Liners should be shop-installed by experienced shop mechanics, preferably with controlled inspection. The fasteners should be pre-cut to calculated lengths, such that when fully inserted in the designed holes, their ends are visible at the face of the liner. This will provide the installer an opportunity to verify that the fasteners are in place and fully inserted. (See Fig. 10a-c.)

6.6 Code requirements must be considered as minimums and not as viable substitutes for a completely engineered stone cladding system.

6.7 *Adhered Stone System Without Mechanical Anchors:*

6.7.1 Stone cladding secured by full adhesion without mechanical engagement of an anchor is an adhered system. Adhesion might be provided by polymer or cementitious compounds including but not limited to epoxy (polyester resins not permitted), structural sealant, portland cement mortar or modified portland cement mortars, and stone adhered to a structural backing in a manufacturing process. Use only adhesive compounds that are compatible with both the stone material and the substrate, and do not exhibit long-term creep. Do not use adhesive compounds that create staining or other long-term weathering defects. Adhered systems should conform to provisions 6.7.2 – 6.7.11.

6.7.2 Limit use of adhered stone systems to a height of 30 ft (10 m) above grade. Inspect the cladding hands-on approximately one year after installation, then at least once every four years to verify system is performing adequately in its application.

6.7.3 Only allow use of adhered stone systems on vertical planes or those that tilt backward where the cladding faces skyward. Do not use adhered stone systems overhead or on planes that tilt forward where cladding faces downward, or when bottom edge occurs directly over an opening more than 5 ft (1.5 m) above grade without supplemental mechanical anchors. Keep adhered systems a minimum 6 in. (150 mm) above grade. Do not allow the stone or setting bed's top edge, or the bonding plane, to be exposed to precipitation.

6.7.4 Total weight of stone cladding system, consisting of stone panels, joint filler, setting bed and all other lath or waterproofing adhered to the backup substrate shall not exceed 25 lb/ft² (120 kg/m²). Limit maximum stone weight to 15 lb/ft² (70 kg/m²).

6.7.5 Maximum panel size should not exceed 3 ft² (0.25 m²) and maximum height or width should not exceed 2 ft (600 mm), except for stone adhered to a structural backing in a manufacturing process. Maximum panel size can be increased to 5 ft² (0.42 m²) and maximum height or width can be increased to 3 ft (0.9 m) if the supporting substrate meets 6.7.8 stiffness criteria horizontally and vertically, and 6.7.9 adhesion parameters are visually verified for every panel during installation.

6.7.6 Use only stone material having physical properties that are suitable for mechanically-attached systems, free of cracks, seams, and any other characteristic that could compromise the structural integrity of the panel or its adhesive attachment. Clean the back surface to be adhered of all dirt, debris, loose stone or sediment before applying adhesive.

6.7.7 Provide movement joints to relieve in-plane movement stresses and prevent development of excessive in-plane shear between the cladding and backup support. To limit cracking, unless engineering analysis proves different joint spacing or joint