International Standard



3462

INTERNATIONAL ORGANIZATION FOR STANDARDIZATION • МЕЖДУНАРОДНАЯ ОРГАНИЗАЦИЯ ПО СТАНДАРТИЗАЦИИ • ORGANISATION INTERNATIONALE DE NORMALISATION

Tractors and machinery for agriculture and forestry — Seat reference point — Method of determination

Tracteurs et matériels agricoles — Point de référence du siège — Méthode de détermination

First edition — 1980-11-01

iTeh STANDARD PREVIEW
(standards.iteh.ai)

ISO 3462:1980

<https://standards.iteh.ai/catalog/standards/sist/178a37a3-3221-454d-a0dc-292f1deaf960/iso-3462-1980>

UDC 631.372 : 629.11.014

Ref. No. ISO 3462-1980 (E)

Descriptors : agricultural machinery, tractors, seats, ground vehicle seats, human factors engineering, H point.

Foreword

ISO (the International Organization for Standardization) is a worldwide federation of national standards institutes (ISO member bodies). The work of developing International Standards is carried out through ISO technical committees. Every member body interested in a subject for which a technical committee has been set up has the right to be represented on that committee. International organizations, governmental and non-governmental, in liaison with ISO, also take part in the work.

Draft International Standards adopted by the technical committees are circulated to the member bodies for approval before their acceptance as International Standards by the ISO Council.

International Standard ISO 3462 was developed by Technical Committee ISO/TC 23, *Tractors and machinery for agriculture and forestry*, and was circulated to the member bodies in January 1979.

It has been approved by the member bodies of the following countries:

Australia	Israel	South Africa, Rep. of
Austria	Italy	Spain
Belgium	Korea, Dem. P. Rep. of	Sweden
Bulgaria	Korea, Rep. of	Switzerland
Chile	Libyan Arab Jamahiriya	Turkey
Czechoslovakia	Mexico	United Kingdom
Denmark	New Zealand	USA
Finland	Poland	USSR
France	Portugal	
Germany, F. R.	Romania	

The member body of the following country expressed disapproval of the document on technical grounds:

Canada

Tractors and machinery for agriculture and forestry — Seat reference point — Method of determination

0 Introduction

This International Standard is intended to be used during a transitional period, until sufficient experience has been gained on the determination of the seat index point in accordance with ISO 5353 and on the relationship between that point and the seat reference point.

Consideration will then be given to the use of the seat index point, instead of the seat reference point, as the appropriate point of reference in relevant International Standards relating to tractors and machinery for agriculture and forestry.

The correlation between the seat index point, determined in accordance with ISO 5353, and the seat reference point, determined in accordance with this International Standard, is as follows :

The seat index point is located 97 mm above and 130 mm in front of the seat reference point.

1 Scope and field of application

This International Standard specifies a method for establishing the positions of the seat reference points for seats designed for upright seated operators of tractors and machinery for agriculture and forestry.

2 Reference

ISO 5353, *Earth-moving machinery — Seat index point*.

3 Definition

For the purpose of this International Standard, the following definition shall apply.

seat reference point : The point in the central longitudinal plane of the seat where the tangential plane of the lower back-rest and a horizontal plane intersect. This horizontal plane cuts the lower surface of the seat-pan board 150 mm in front of the plane parallel to the rear face of the lower back-rest board.

4 Apparatus

The apparatus required is a device as shown in figure 1.

5 Method of determining the seat reference point

The device shall be positioned on the seat (see figure 2), with its central longitudinal plane coincident with the central longitudinal plane of the seat. It shall then be loaded with a force of 550 N acting vertically at a point 50 mm in front of joint A, and the two parts of the back-rest board shall be lightly pressed tangentially against the back-rest.

If it is not possible to determine definite tangents to each area of the back-rest (below and above the lumbar region), the following procedure shall be adopted :

- a) no definite tangent to the lower area possible :

The lower part of the back-rest board in a vertical position shall be lightly pressed against the back-rest.

- b) no definite tangent to the upper area possible :

With both parts of the back-rest board in a vertical position, the device shall be lightly pressed against the back-rest.

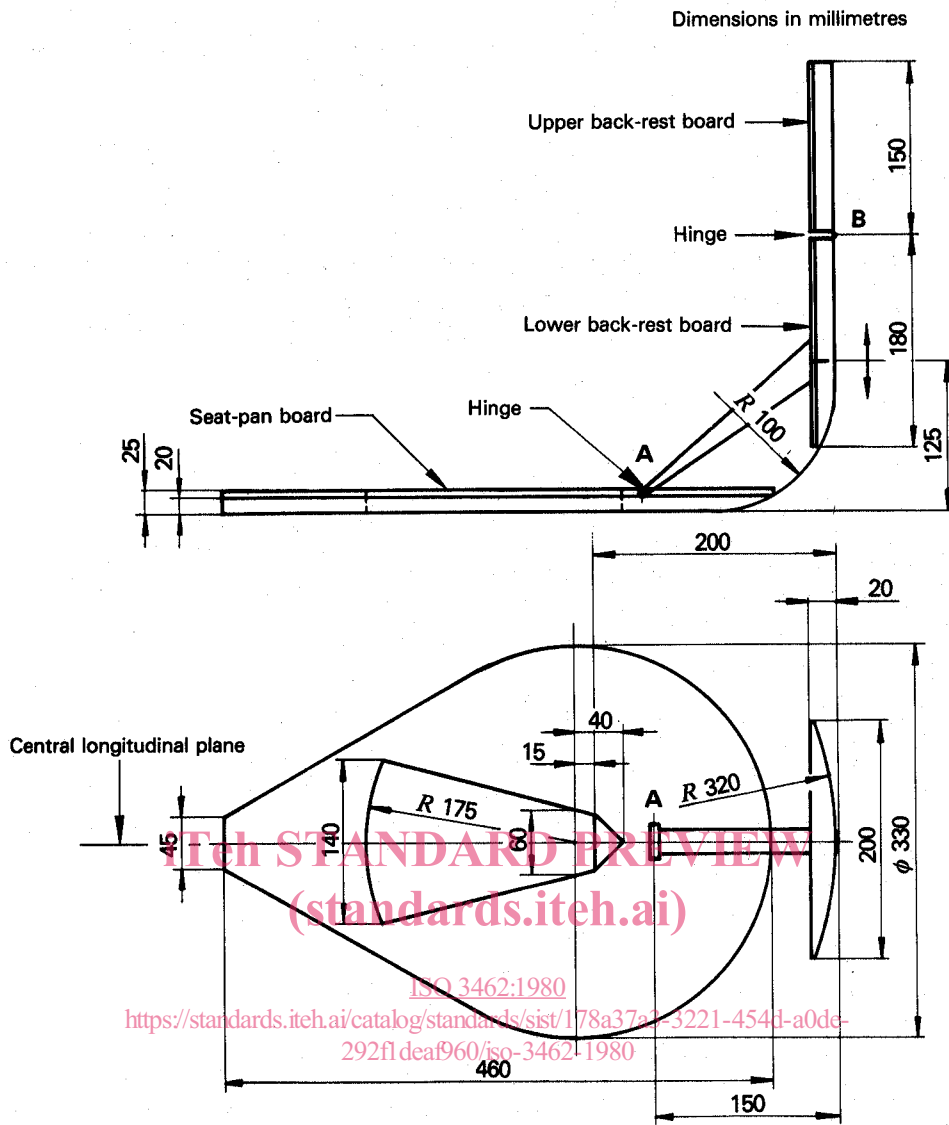

Figure 1 – Device for determining the seat reference point

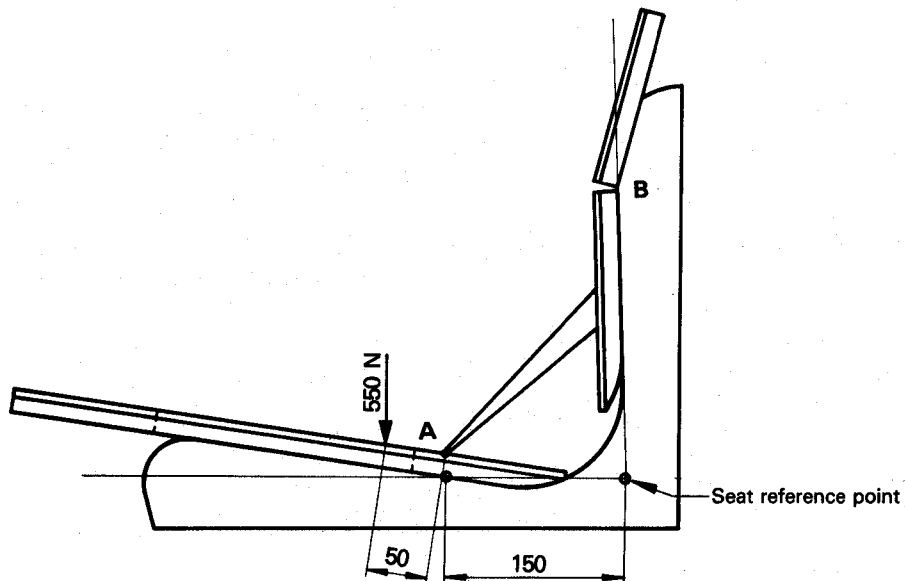

Figure 2 – Device position