



Designation: ~~C1108–99(Reapproved2006)~~ Designation: C1108 – 12

## Standard Test Method for Plutonium by Controlled-Potential Coulometry<sup>1</sup>

This standard is issued under the fixed designation C1108; the number immediately following the designation indicates the year of original adoption or, in the case of revision, the year of last revision. A number in parentheses indicates the year of last reapproval. A superscript epsilon ( $\epsilon$ ) indicates an editorial change since the last revision or reapproval.

### 1. Scope

1.1 This test method describes the determination of dissolved plutonium in solutions off from unirradiated nuclear-grade (that is, high-purity) materials by controlled-potential coulometry. Controlled-potential coulometry may be performed in a choice of supporting electrolytes, such as 0.9 M HNO<sub>3</sub>, 1 M HClO<sub>4</sub>, 1 M HCl, 5 M HCl, and 0.5 M H<sub>2</sub>SO<sub>4</sub>. Limitations on the use of selected supporting electrolytes are discussed in Section 5. Optimum quantities of plutonium for this procedure are 5 to ~~10~~20 mg.

1.2 Plutonium-bearing materials are radioactive and toxic. Adequate laboratory facilities, such as gloved boxes, fume hoods, controlled ventilation, etc., along with safe techniques must be used in handling specimens containing these materials.

1.3 The values stated in SI units are to be regarded as the standard. The values given in parentheses are for information only.

1.4 *This standard does not purport to address all of the safety concerns, if any, associated with its use. It is the responsibility of the user of this standard to establish appropriate safety and health practices and determine the applicability of regulatory limitations prior to use.*

### 2. Referenced Documents

2.1 *ASTM Standards:*<sup>2</sup>

C859 [Terminology Relating to Nuclear Materials](#)

C1009 [Guide for Establishing a Quality Assurance Program for Analytical Chemistry Laboratories Within the Nuclear Industry](#)

C1068 [Guide for Qualification of Measurement Methods by a Laboratory Within the Nuclear Industry](#)

C1128 [Guide for Preparation of Working Reference Materials for Use in Analysis of Nuclear Fuel Cycle Materials](#)

C1156 [Guide for Establishing Calibration for a Measurement Method Used to Analyze Nuclear Fuel Cycle Materials](#)

C1168 [Practice for Preparation and Dissolution of Plutonium Materials for Analysis](#)

C1210 [Guide for Establishing a Measurement System Quality Control Program for Analytical Chemistry Laboratories Within the Nuclear Industry](#)

C1297 [Guide for Qualification of Laboratory Analysts for the Analysis of Nuclear Fuel Cycle Materials](#)

E691 [Practice for Conducting an Interlaboratory Study to Determine the Precision of a Test Method](#)

### 3. Summary of Test Method

3.1 In a controlled-potential coulometric measurement, the substance being determined reacts at a stationary electrode, the potential of which is maintained at such a value that unwanted electrode reactions are precluded under the prevailing experimental conditions. Those substances which have reduction-oxidation (redox) potentials near that of the ion being determined constitute interferences. Electrolysis current decreases exponentially as the reaction proceeds, until constant background current is obtained. Detailed discussions of the theory and applications of this technique have been published (**1, 2, 3, 4, 5, 6**).<sup>3</sup> The control-potential adjustment technique (**7**) can be used to terminate the electrolysis of the specimen at constant background current without exhaustive electrolysis with considerable reduction in operating time. Use of the control-potential adjustment technique requires that the coulometer integrator be capable of operations in a bipolar mode and that the plutonium-containing solution be of high purity, that is, nuclear grade.

3.2 Plutonium(IV) is reduced to Pu(III) at a working electrode maintained at a potential more negative than the formal redox potential. Plutonium(III) is oxidized to Pu(IV) at a potential more positive than the formal redox potential. The quantity of plutonium electrolyzed is calculated from the net number of coulombs required for the electrolysis, according to Faraday's law. Corrections for incomplete reaction, derived from the Nernst equation, must be applied for electrolysis of the sample aliquot (**7, 8**).

<sup>1</sup> This test method is under the jurisdiction of ASTM Committee C26 on Nuclear Fuel Cycle and is the direct responsibility of Subcommittee C26.05 on Methods of Test. Current edition approved July 1, 2006; 2012. Published October 2006; July 2012. Originally approved in 1988. Last previous edition approved in 1999; 2006 as C1108 – 99 (2006). DOI: 10.1520/C1108-99R0612.

<sup>2</sup> For referenced ASTM standards, visit the ASTM website, www.astm.org, or contact ASTM Customer Service at service@astm.org. For *Annual Book of ASTM Standards* volume information, refer to the standard's Document Summary page on the ASTM website.

<sup>3</sup> The boldface numbers in parentheses refer to the list of references at the end of this test method.

$$W = \frac{(Q_s - Q_b) M}{nFf} \quad (1)$$

**C1108-12\_1**

where:

$W$  = grams of plutonium,

$Q_s$  = coulombs required by the electrolysis,

$Q_b$  = coulombs of background current,

$M$  = gram-atomic weight of plutonium (must be adjusted for isotopic composition),

$n$  = number of electrons involved in the electrode reaction (for Pu(III) → Pu(IV),  $n = 1$ ),

$F$  = Faraday constant, coulombs/equivalent,<sup>4</sup> and

$f$  = fraction of plutonium electrolyzed.

#### 4. Significance and Use

4.1 Factors governing selection of a method for the determination of plutonium include available quantity of sample, sample purity, desired level of reliability, and equipment.

4.1.1 This test method determines 5 to ~~±0.20~~ mg of plutonium with prior dissolution using Practice C1168.

~~4.1.2 This test method calculates plutonium assay using physical constants as reference standards.~~

~~4.1.3 Chemical standards are used for quality control when prior chemical separation of plutonium is necessary to remove interferences~~

4.1.2 This test method calculates plutonium concentration in solutions or mass fraction in solids using an electrical calibration based upon Ohm's Law and the Faraday Constant.

4.1.3 Chemical standards are used for quality control. When prior chemical separation of plutonium is necessary to remove interferences, the quality control standards should be included with each chemical separation batch (9).

4.2 *Committee C-26 Safeguards Statement*<sup>5</sup>:

4.2.1 The materials (plutonium metal, plutonium oxide or mixed oxide [(U, Pu) O<sub>2</sub>] powders and pellets) to which this test method applies are subject to nuclear safeguards regulations governing their possession and use. Materials for use by the commercial nuclear community must also meet compositional specifications.

4.2.2 The analytical method in this test method both meets U. S. Department of Energy guidelines for acceptability of a measurement method for generation of safeguards accountability measurement data and also provides data that may be used to demonstrate specification compliance in buyer-seller interactions.

#### 5. Interferences

5.1 Interference is caused by ions that are electrochemically active in the range of redox potentials used or by species that prevent attainment of 100 % current efficiency (for example, reductants, oxidants, and organic matter).

5.2 *Polymer*—Polymerized plutonium is not electrochemically active (10) and thus is neither reduced nor oxidized. The presence of polymerized plutonium will give low results. The polymer may be converted to electrochemically active species by HF treatment (10).

5.3 *Pu(VI)*—Plutonium(VI) is only partially reduced to Pu(III) in 1 M HNO<sub>3</sub>, ~~HCl, or HClO<sub>4</sub>~~, 1 M HCl, or 1 M HClO<sub>4</sub> supporting electrolyte solutions; therefore, the presence of Pu(VI) can lead to inaccurate results when present even as a small fraction of the total plutonium. Plutonium(VI) is can be completely reduced in 0.5 M H<sub>2</sub>SO<sub>4</sub> (10) or 5.5 M HCl (11) supporting electrolyte. supporting electrolyte, however, quantitative reduction has not been demonstrated when the control-potential adjustment technique used in this standard test method is applied.

5.4 *Iron*—In 0.5 M H<sub>2</sub>SO<sub>4</sub> supporting electrolyte, iron is reduced and oxidized at essentially the same formal redox potentials as the Pu(III)-Pu(IV) couple and thus constitutes a direct interference. Iron must be removed by prior separation, or the effect of its presence must be corrected by a separate measurement of the iron concentration in the sample solution. In 1 M HCl, 1 M HNO<sub>3</sub>, or 1 M HClO<sub>4</sub>, iron interferes to a much lesser extent. The effect of iron in these supporting electrolytes may be minimized by the choice of redox potentials, by a secondary titration (10), or by electrochemical correction (12, 13) .

5.5 *Nitrites*—Nitrites are electrochemically active; therefore, saturated sulfamic acid solution should be added to the electrolyte in the cell to destroy any interfering nitrites when a nitric acid supporting electrolyte is used.

5.6 *Sulfate*—Because of the complexing action of sulfate on Pu(IV) and the resultant shift in the redox potential of the Pu(III)-Pu(IV) couple, that is, the formal potential, only small amounts of sulfate are tolerable in HNO<sub>3</sub>, HCl, and HClO<sub>4</sub> electrolytes. When using these supporting electrolytes, specimens should be fumed to dryness to assure adequate removal of excess sulfate (see 4.1.3)-11.3.1.3). For aliquots of dissolved MOX fuels that have not been purified by anion exchange to remove the

<sup>4</sup> Based upon Committee C26 Safeguards Matrix (C1009, C1068, C1128, C1156, C1210, and C1297).

<sup>4</sup> Committee on Data for Science and Technology, CODATA, internationally recommended values for fundamental physical constants are available at URL <http://physics.nist.gov/cuu/Constants/index.html>.

<sup>5</sup> A Hewlett-Packard 3455A DVM has been found to exceed these specifications.

<sup>5</sup> Based upon Committee C26 Safeguards Matrix (C1009, C1068, C1128, C1156, C1210, and C1297).

uranium, the sulfate concentration after fuming will still be elevated. A formal potential should be measured for the specific U:Pu ratio and used in the calculations for these aliquots.

NOTE 1—Interference from a sulfate concentration of  $>0.004\text{ M}$  in  $1\text{ M HClO}_4$  has been reported (10).

5.7 *Fluoride*—Free fluoride cannot be tolerated and must be removed from the specimen. Evaporation of the specimen in  $\text{HNO}_3$  to a low volume and fuming with  $\text{H}_2\text{SO}_4$  are effective in removing fluoride.

5.8 *Oxygen*—In  $\text{HNO}_3$ ,  $\text{HCl}$ , and  $\text{HClO}_4$  supporting electrolytes, oxygen may be an interference. In  $\text{H}_2\text{SO}_4$ , oxygen does interfere and must be removed. Purging the specimen with high-purity argon prior to and during the coulometric determination is recommended for all electrolytes. supporting electrolyte, oxygen interferes and must be removed. In  $\text{HNO}_3$ ,  $\text{HCl}$ , and  $\text{HClO}_4$  supporting electrolytes, oxygen may be an interference, depending upon experimental conditions. Purging the specimen with high-purity argon prior to and during the coulometric determination is recommended for all electrolytes.

## 6. Apparatus

6.1 *Controlled-Potential Coulometer*—A coulometer with the following specifications is recommended to achieve highly precise and accurate results. (Room temperature stability of  $\pm 1^\circ\text{C}$  is recommended to ensure optimum instrument performance. Instruments with smaller output current or smaller voltage span may be satisfactory.)

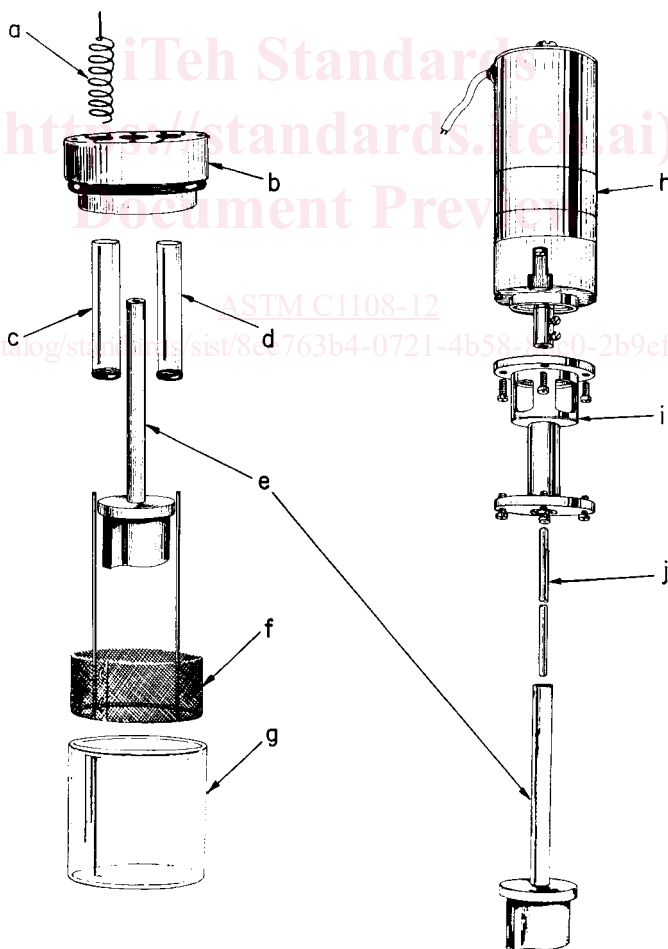

FIG. 1 Exploded View of Cell Assembly: (a) Counter Electrode, (b) Cell Head, (c) Counter Electrode Frit Tube, (d) Reference Electrode Frit Tube, (e) NBL-Designed S-Shaped Stirrer, (f) Working Electrode, (g) Sample Cell, (h) Stirrer Motor, (i) Motor Pedestal and Bearing, and (j) Stirrer Shaft

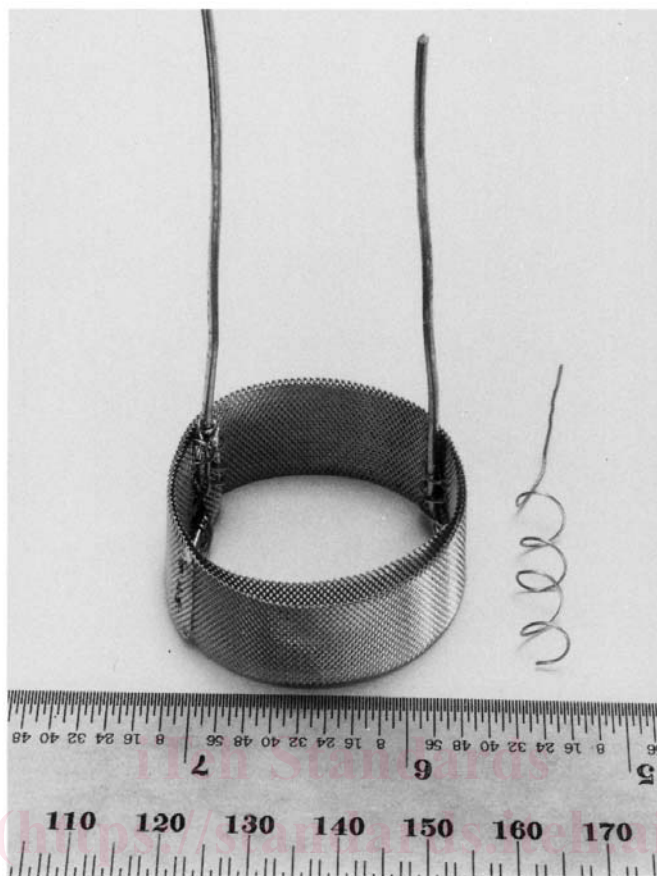

FIG. 2 Working Electrode (Top View)

Potentiostat (6)

Output voltage	>25 V
Output current	>200 mA
Open-loop response d-c gain	>10 <sup>5</sup>
Unity-gain bandwidth	>300 kHz
Full-power response	>10 kHz (slewing rate 0.5 V/μs)
Voltage zero offset stability	>1-mV long term
Input d-c resistance	>50 MΩ
Input d-c current	<50 nA
d-c control voltage span	±4 V
Resolution, hum, and drift	<1 mV
Stability through extreme of line and load variation	±5 mV

Digital Integrator (14)

Nonlinearity of V/F converter	<0.01 % full scale
—Full scale error	adjustable to zero
Full scale set-point	adjustable to ±0.01 % of full scale
—Input offset voltage error	adjustable to zero
Input offset voltage set-point	adjustable to ±0.01 % of full scale
Output readability	<1 μg Pu
Integrating capacity	>10 C
—Accuracy	<0.01 %
Bias	<0.01 %

6.2 *Digital Voltmeter*, 15-V range, 5½ digits accurate to 0.01 % of full scale on all ranges. Input resistance >10<sup>10</sup>Ω.<sup>6</sup>

6.3 *Cell Assembly*—The success of controlled-potential coulometric methods is strongly dependent on the design of the cell. The cell dimensions, electrode area, spacing, and stirring rate are important parameters in a design that will minimize the time required for titration. The following components are required for the recommended cell assembly (Fig. 1).

6.3.1 *Cell*—The coulometry cell is fabricated from a cut-off 50-mL borosilicate glass beaker with an inside diameter of 38 mm and a height of 42 mm; the cut edges are rounded and polished smooth. Other cells conforming to these dimensions are satisfactory.

<sup>6</sup> Either a test tube with unfired Vycor bottoms of Type 7930 glass obtained from Corning Glass Works, or a 0.5 cm long, 0.5 cm diameter rod of unfired Vycor Type 7930 sealed into one end of a glass tube with heat-shrinkable TFE-fluorocarbon tubing, has been found satisfactory for this application.

<sup>7</sup> A Hewlett-Packard 3455A DVM has been found to exceed these specifications.

6.3.2 *Counter Electrode and Salt Bridge Tube*—The counter electrode is a coiled length of 0.51-mm (0.020-in.) diameter platinum wire. The salt bridge tube is unfired high-silica glass<sup>7</sup> filled with the supporting electrolyte solution.

6.3.3 *Reference Electrode and Salt Bridge Tube*—The reference electrode is a miniature saturated-calomel electrode (SCE).<sup>8</sup> The salt bridge is identical to the salt bridge described in 6.3.2 and is also filled with supporting electrolyte solution.

6.3.4 *Working Electrode*, fabricated from either 8Au8-5/0 expanded annealed-gold metal or from 45-mesh platinum gauze (Fig. 2). Storage of either electrode in 8 M HNO<sub>3</sub> when not in use and rinsing with 8 M HNO<sub>3</sub> between specimens are normally adequate to maintain satisfactory electrode response. (Satisfactory response may be defined as the ability of the electrode to oxidize and reduce the supporting electrolyte to 1 to 2 μA in about 3 min with the current following an exponential curve.) If such electrode response is not obtained, the following electrode reconditioning treatments, in increasing order of severity, have been found to be successful in restoring response:

6.3.4.1 The gold electrode may be: (1) briefly dipped in cold concentrated HCl and thoroughly rinsed with 8 M HNO<sub>3</sub>; (2) briefly dipped in hot HCl and thoroughly rinsed with HNO<sub>3</sub>; (3) briefly dipped in aqua regia and thoroughly rinsed with HNO<sub>3</sub>; or (4) soaked 10 min in the sulfuric acid-hydrofluoric acid mixture (7.16), the residual acid removed by fuming and the hot electrode quenched in 8 M HNO<sub>3</sub>. After each treatment, the electrode is stored in 8 M HNO<sub>3</sub> overnight. Following overnight storage, conditioning, that is, alternating reduction and oxidation of the supporting electrolyte with and without plutonium, may be required to achieve desired electrode performance.

6.3.4.2 The platinum electrode may be subjected to any of the above treatments, or it may be: (1) heated to red heat in a gas flame and quenched in 8 M HNO<sub>3</sub> or (2) heated in a furnace to 900°C and quenched in 8 M HNO<sub>3</sub>. Do not use these latter treatments on gold electrodes as melting may occur.

6.3.4.1 Store and condition the working electrode in accordance with instruction in Section 10.

6.3.5 *Stirrer*—Several types of stirrers have performed satisfactorily. A paddle-type stirrer capable of being driven at 1800 r/min by a synchronous motor, or a magnetically driven stirring bar, is adequate. Magnetic stirring slightly simplifies the arrangement of the cell cap. For optimum stirring efficiency with freedom from losses due to splashing, an S-shaped polytetrafluoroethylene stirrer (Fig. 3) (15) driven by synchronous motor is recommended.

6.3.6 *Inert Gas Inlet Tube*—A polyvinyl chloride tube, approximately 3 mm in outside diameter (1 mm in inside diameter), is inserted so that its tip is about 10 mm above the surface of the electrolyte solution. The gas flow is adjusted so that the surface of the solution is depressed almost 3 mm. The gas is high-purity argon. While inert gas is not required for all electrolytes, it is recommended for this procedure.

6.4 *Quartz Heating Lamps*—Optimum heating or evaporating efficiency without bumping of solutions, or both, is obtained using overhead heating with quartz heat lamps<sup>9</sup> controlled by a variable power supply. However, with proper care, other conventional means of heating may be used.

6.5 *Hot Plate*—Recommended for heating during the plutonium oxidation state adjustment with hydrogen peroxide.

6.6 *Quartz Clock Timer*, accurate to 0.001 s.

6.7 *100-Ω Precision Resistor*, accurate to better than 0.01 %.<sup>10</sup>

## 7. Reagents and Materials

7.1 *Purity of Reagents*—Reagent grade chemicals shall be used in all tests. Unless otherwise indicated, it is intended that all reagents conform to the specifications of the Committee on Analytical Reagents of the American Chemical Society where such specifications are available.<sup>11</sup> Other grades may be used, provided it is first ascertained that the reagent is of sufficiently high purity to permit its use without lessening the accuracy of the determination.<sup>12</sup>

7.2 *Argon*, greater than 99.99 % purity.

7.3 *Hydrochloric Acid*, concentrated hydrochloric acid (HCl, specific gravity 1.19).

<sup>7</sup> A Fisher Calomel Reference Electrode Catalog No. 13-639-79 has been found satisfactory.

<sup>7</sup> Either a test tube with unfired Vycor bottoms of Type 7930 glass obtained from Corning Glass Works, or a 0.5 cm long, 0.5-cm diameter rod of unfired Vycor Type 7930 sealed into one end of a glass tube with heat-shrinkable TFE-fluorocarbon tubing, has been found satisfactory for this application.

<sup>8</sup> Quartz heating lamps and Quartz epiradiator lamps, Model 534 RCL, 500 watts, 120 V (Atlas Electric Supplies, P.O. Box 1300, Hialeah, Florida, 33011) have been found to be satisfactory.

<sup>8</sup> A Fisher Calomel Reference Electrode Catalog No. 13-639-79 has been found satisfactory.

<sup>9</sup> A Julie 100-Ω precision resistor number NB102A, accurate to 0.0015%, has been found satisfactory.

<sup>9</sup> Quartz heating lamps and Quartz epiradiator lamps, Model 534 RCL, 500 watts, 120 V (Atlas Electric Supplies, P.O. Box 1300, Hialeah, Florida, 33011) have been found to be satisfactory.

<sup>10</sup> Reagent Chemicals, American Chemical Society Specifications, American Chemical Society, Washington, DC. For suggestions on the testing of reagents not listed by the American Chemical Society, see *Analar Standards for Laboratory Chemicals*, BDH Ltd., Poole, Dorset, U.K., and the *United States Pharmacopeia and National Formulary*, U.S. Pharmacopeial Convention, Inc. (USPC), Rockville, MD.

<sup>10</sup> A Julie 100-Ω precision resistor number NB102A, accurate to 0.0015 %, has been found satisfactory.

<sup>11</sup> 0.9 M HNO<sub>3</sub> is used because the range from 0.8 to 1.0 M HNO<sub>3</sub> provides a stable formal potential for the Pu<sup>3+</sup>/Pu<sup>4+</sup> couple.

<sup>11</sup> Reagent Chemicals, American Chemical Society Specifications, American Chemical Society, Washington, DC. For suggestions on the testing of reagents not listed by the American Chemical Society, see *Analar Standards for Laboratory Chemicals*, BDH Ltd., Poole, Dorset, U.K., and the *United States Pharmacopeia and National Formulary*, U.S. Pharmacopeial Convention, Inc. (USPC), Rockville, MD.

<sup>12</sup> A Hewlett Packard 3458 digital multimeter has been found satisfactory.

<sup>12</sup> All reagents should be prepared with 18-MΩ-cm deionized (demineralized) water.

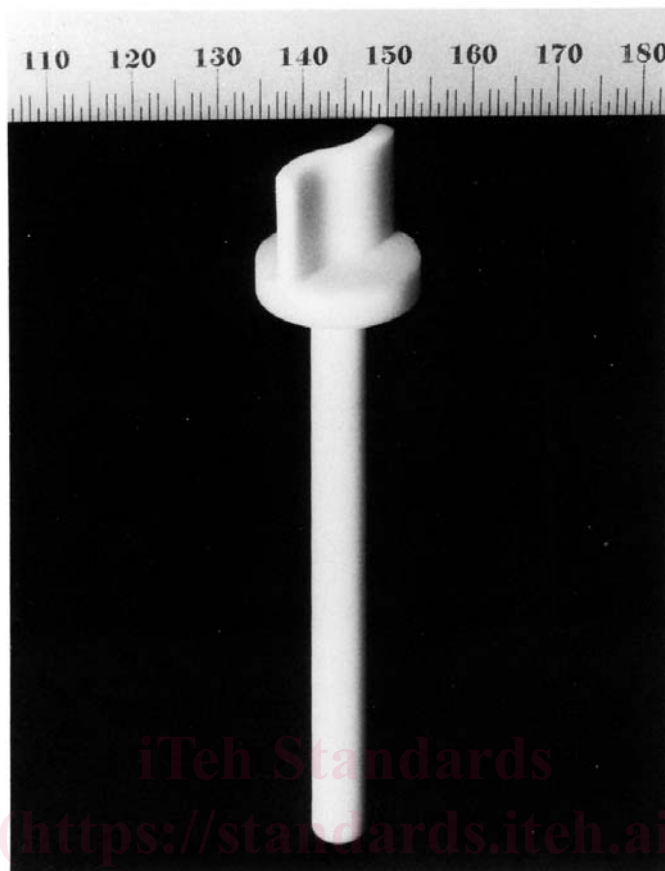

FIG. 3 S-Shaped Stirrer

7.4 *Hydrochloric Acid* (1 M), prepare by diluting 85 mL of hydrochloric acid to 1 L with water.

7.5 *Hydrochloric Acid-Nitric Acid-Hydrofluoric Acid Mixture* (5.4 M HCl-1.6 M HNO<sub>3</sub>-0.014 M HF)—Prepare by slowly adding 450 mL hydrochloric acid, 100 mL nitric acid, and 10 drops hydrofluoric acid to 450 mL water in a polytetrafluoroethylene beaker. Cool and store in a tetrafluoroethylene (TFE) fluorocarbon bottle.

7.6 *Hydrofluoric Acid*, concentrated hydrofluoric acid (HF, 48 %).

7.7 *Hydrogen Peroxide*, 30 % solution of hydrogen peroxide (H<sub>2</sub>O<sub>2</sub>).

7.8 *Nitric Acid*, concentrated nitric acid (HNO<sub>3</sub>, specific gravity 1.42).

7.9 *Nitric Acid* (8 M)—Prepare by diluting 500 mL nitric acid to 1 L with water.

7.10 *Nitric Acid* (0.9 M)—Prepare by diluting 57 mL of nitric acid to 1 L with water.<sup>13</sup>

7.11 *Perchloric Acid* (1 M)—Prepare by diluting 85 mL of perchloric acid (HClO<sub>4</sub>, specific gravity 1.76) to 1 L with water.

7.12 *Plutonium Standard Solution*—Dissolve plutonium metal (NBL CRM 126, current issue) in an Erlenmeyer flask by slow addition of approximately 30 mL of hydrochloric acid-nitric acid-hydrofluoric acid mixture. Add 30 mL of 8 M HNO<sub>3</sub>; evaporate to less than 15 mL. Transfer to a tared container with the 8 M HNO<sub>3</sub> and dilute to about 100 mL with 8 M HNO<sub>3</sub> prior to aliquotting. Proceed to 11.3.1.3.

7.13 *Sulfamic Acid* (NH<sub>2</sub>SO<sub>3</sub>H), saturated solution.

7.14 *Sulfuric Acid* (0.5 M)—Prepare by adding 28 mL of sulfuric acid (H<sub>2</sub>SO<sub>4</sub>, specific gravity 1.84) to water with constant stirring and dilute to 1 L.

7.15 *Sulfuric Acid* (3 M)—Prepare by adding 167 mL of sulfuric acid (H<sub>2</sub>SO<sub>4</sub>, specific gravity 1.84) to water with constant stirring and dilute to 1 L.

7.16 *Sulfuric Acid-Hydrofluoric Acid Mixture* (8.1 M H<sub>2</sub>SO<sub>4</sub>-2.9 M HF)—Prepare by adding 45 mL of sulfuric acid (H<sub>2</sub>SO<sub>4</sub>, specific gravity 1.84) to 45 mL of water with constant stirring. Add 10 mL of hydrofluoric acid, cool, and store in a TFE-fluorocarbon polymer bottle.

<sup>13</sup> Adjust the solution weight so that the overall weighing error of each 5 to 10-mg aliquot of plutonium is 0.01%.

<sup>13</sup> 0.9 M HNO<sub>3</sub> is used because the range from 0.8 to 1.0 M HNO<sub>3</sub> provides a stable formal potential for the Pu<sup>3+</sup>/Pu<sup>4+</sup> couple.