



Designation: C1108 – 12

Standard Test Method for Plutonium by Controlled-Potential Coulometry¹

This standard is issued under the fixed designation C1108; the number immediately following the designation indicates the year of original adoption or, in the case of revision, the year of last revision. A number in parentheses indicates the year of last reappraisal. A superscript epsilon (ϵ) indicates an editorial change since the last revision or reappraisal.

1. Scope

1.1 This test method describes the determination of dissolved plutonium from unirradiated nuclear-grade (that is, high-purity) materials by controlled-potential coulometry. Controlled-potential coulometry may be performed in a choice of supporting electrolytes, such as 0.9 M HNO₃, 1 M HClO₄, 1 M HCl, 5 M HCl, and 0.5 M H₂SO₄. Limitations on the use of selected supporting electrolytes are discussed in Section 5. Optimum quantities of plutonium for this procedure are 5 to 20 mg.

1.2 Plutonium-bearing materials are radioactive and toxic. Adequate laboratory facilities, such as gloved boxes, fume hoods, controlled ventilation, etc., along with safe techniques must be used in handling specimens containing these materials.

1.3 The values stated in SI units are to be regarded as the standard. The values given in parentheses are for information only.

1.4 *This standard does not purport to address all of the safety concerns, if any, associated with its use. It is the responsibility of the user of this standard to establish appropriate safety and health practices and determine the applicability of regulatory limitations prior to use.*

2. Referenced Documents

2.1 ASTM Standards:²

C859 Terminology Relating to Nuclear Materials

C1009 Guide for Establishing and Maintaining a Quality Assurance Program for Analytical Laboratories Within the Nuclear Industry

C1068 Guide for Qualification of Measurement Methods by a Laboratory Within the Nuclear Industry

C1128 Guide for Preparation of Working Reference Materials for Use in Analysis of Nuclear Fuel Cycle Materials

C1156 Guide for Establishing Calibration for a Measurement Method Used to Analyze Nuclear Fuel Cycle Materials

C1168 Practice for Preparation and Dissolution of Plutonium Materials for Analysis

C1210 Guide for Establishing a Measurement System Quality Control Program for Analytical Chemistry Laboratories Within the Nuclear Industry

C1297 Guide for Qualification of Laboratory Analysts for the Analysis of Nuclear Fuel Cycle Materials

E691 Practice for Conducting an Interlaboratory Study to Determine the Precision of a Test Method

3. Summary of Test Method

3.1 In a controlled-potential coulometric measurement, the substance being determined reacts at a stationary electrode, the potential of which is maintained at such a value that unwanted electrode reactions are precluded under the prevailing experimental conditions. Those substances which have reduction-oxidation (redox) potentials near that of the ion being determined constitute interferences. Electrolysis current decreases exponentially as the reaction proceeds, until constant background current is obtained. Detailed discussions of the theory and applications of this technique have been published (1, 2, 3, 4, 5, 6).³ The control-potential adjustment technique (7) can be used to terminate the electrolysis of the specimen at constant background current without exhaustive electrolysis with considerable reduction in operating time. Use of the control-potential adjustment technique requires that the coulometer integrator be capable of operations in a bipolar mode and that the plutonium-containing solution be of high purity, that is, nuclear grade.

3.2 Plutonium(IV) is reduced to Pu(III) at a working electrode maintained at a potential more negative than the formal redox potential. Plutonium(III) is oxidized to Pu(IV) at a potential more positive than the formal redox potential. The quantity of plutonium electrolyzed is calculated from the net number of coulombs required for the electrolysis, according to Faraday's law. Corrections for incomplete reaction, derived from the Nernst equation, must be applied for electrolysis of the sample aliquot (7, 8).

¹ This test method is under the jurisdiction of ASTM Committee C26 on Nuclear Fuel Cycle and is the direct responsibility of Subcommittee C26.05 on Methods of Test.

Current edition approved July 1, 2012. Published July 2012. Originally approved in 1988. Last previous edition approved in 2006 as C1108 – 99 (2006). DOI: 10.1520/C1108-12.

² For referenced ASTM standards, visit the ASTM website, www.astm.org, or contact ASTM Customer Service at service@astm.org. For *Annual Book of ASTM Standards* volume information, refer to the standard's Document Summary page on the ASTM website.

³ The boldface numbers in parentheses refer to the list of references at the end of this test method.

$$W = \frac{(Q_s - Q_b) M}{nFf} \quad (1)$$

where:

- W** = grams of plutonium,
Q_s = coulombs required by the electrolysis,
Q_b = coulombs of background current,
M = gram-atomic weight of plutonium (must be adjusted for isotopic composition),
n = number of electrons involved in the electrode reaction (for Pu(III) → Pu(IV), *n* = 1),
F = Faraday constant, coulombs/equivalent,⁴ and
f = fraction of plutonium electrolyzed.

4. Significance and Use

4.1 Factors governing selection of a method for the determination of plutonium include available quantity of sample, sample purity, desired level of reliability, and equipment.

4.1.1 This test method determines 5 to 20 mg of plutonium with prior dissolution using Practice C1168.

4.1.2 This test method calculates plutonium concentration in solutions or mass fraction in solids using an electrical calibration based upon Ohm's Law and the Faraday Constant.

4.1.3 Chemical standards are used for quality control. When prior chemical separation of plutonium is necessary to remove interferences, the quality control standards should be included with each chemical separation batch (9).

4.2 Committee C-26 Safeguards Statement⁵:

4.2.1 The materials (plutonium metal, plutonium oxide or mixed oxide [(U, Pu) O₂] powders and pellets) to which this test method applies are subject to nuclear safeguards regulations governing their possession and use. Materials for use by the commercial nuclear community must also meet compositional specifications.

4.2.2 The analytical method in this test method both meets U. S. Department of Energy guidelines for acceptability of a measurement method for generation of safeguards accountability measurement data and also provides data that may be used to demonstrate specification compliance in buyer-seller interactions.

5. Interferences

5.1 Interference is caused by ions that are electrochemically active in the range of redox potentials used or by species that prevent attainment of 100 % current efficiency (for example, reductants, oxidants, and organic matter).

5.2 *Polymer*—Polymerized plutonium is not electrochemically active (10) and thus is neither reduced nor oxidized. The presence of polymerized plutonium will give low results. The polymer may be converted to electrochemically active species by HF treatment (10).

5.3 *Pu(VI)*—Plutonium(VI) is only partially reduced to Pu(III) in 1 M HNO₃, 1 M HCl, or 1 M HClO₄ supporting

electrolyte solutions; therefore, the presence of Pu(VI) can lead to inaccurate results when present even as a small fraction of the total plutonium. Plutonium(VI) can be completely reduced in 0.5 M H₂SO₄ (10) or 5.5 M HCl (11) supporting electrolyte, however, quantitative reduction has not been demonstrated when the control-potential adjustment technique used in this standard test method is applied.

5.4 *Iron*—In 0.5 M H₂SO₄ supporting electrolyte, iron is reduced and oxidized at essentially the same formal redox potentials as the Pu(III)-Pu(IV) couple and thus constitutes a direct interference. Iron must be removed by prior separation, or the effect of its presence must be corrected by a separate measurement of the iron concentration in the sample solution. In 1 M HCl, 1 M HNO₃, or 1 M HClO₄, iron interferes to a lesser extent. The effect of iron in these supporting electrolytes may be minimized by the choice of redox potentials, by a secondary titration (10), or by electrochemical correction (12, 13).

5.5 *Nitrites*—Nitrites are electrochemically active; therefore, saturated sulfamic acid solution should be added to the electrolyte in the cell to destroy any interfering nitrites when a nitric acid supporting electrolyte is used.

5.6 *Sulfate*—Because of the complexing action of sulfate on Pu(IV) and the resultant shift in the redox potential of the Pu(III)-Pu(IV) couple, that is, the formal potential, only small amounts of sulfate are tolerable in HNO₃, HCl, and HClO₄ electrolytes. When using these supporting electrolytes, specimens should be fumed to dryness to assure adequate removal of excess sulfate (see 11.3.1.3). For aliquots of dissolved MOX fuels that have not been purified by anion exchange to remove the uranium, the sulfate concentration after fuming will still be elevated. A formal potential should be measured for the specific U:Pu ratio and used in the calculations for these aliquots.

NOTE 1—Interference from a sulfate concentration of >0.004 M in 1 M HClO₄ has been reported (10).

5.7 *Fluoride*—Free fluoride cannot be tolerated and must be removed from the specimen. Evaporation of the specimen in HNO₃ to a low volume and fuming with H₂SO₄ are effective in removing fluoride.

5.8 *Oxygen*—In H₂SO₄ supporting electrolyte, oxygen interferes and must be removed. In HNO₃, HCl, and HClO₄ supporting electrolytes, oxygen may be an interference, depending upon experimental conditions. Purging the specimen with high-purity argon prior to and during the coulometric determination is recommended for all electrolytes.

6. Apparatus

6.1 *Controlled-Potential Coulometer*—A coulometer with the following specifications is recommended to achieve highly precise and accurate results. (Room temperature stability of ±1°C is recommended to ensure optimum instrument performance. Instruments with smaller output current or smaller voltage span may be satisfactory.)

Potentiostat (6)	
Output voltage	>25 V
Output current	>200 mA

⁴ Committee on Data for Science and Technology, CODATA, internationally recommended values for fundamental physical constants are available at URL <http://physics.nist.gov/cuu/Constants/index.html>.

⁵ Based upon Committee C26 Safeguards Matrix (C1009, C1068, C1128, C1156, C1210, and C1297).

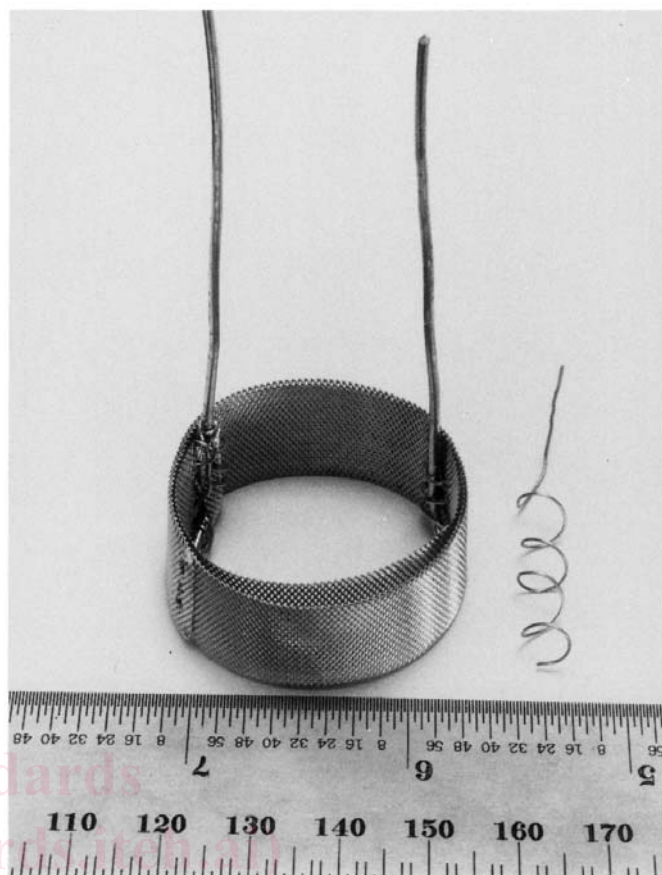
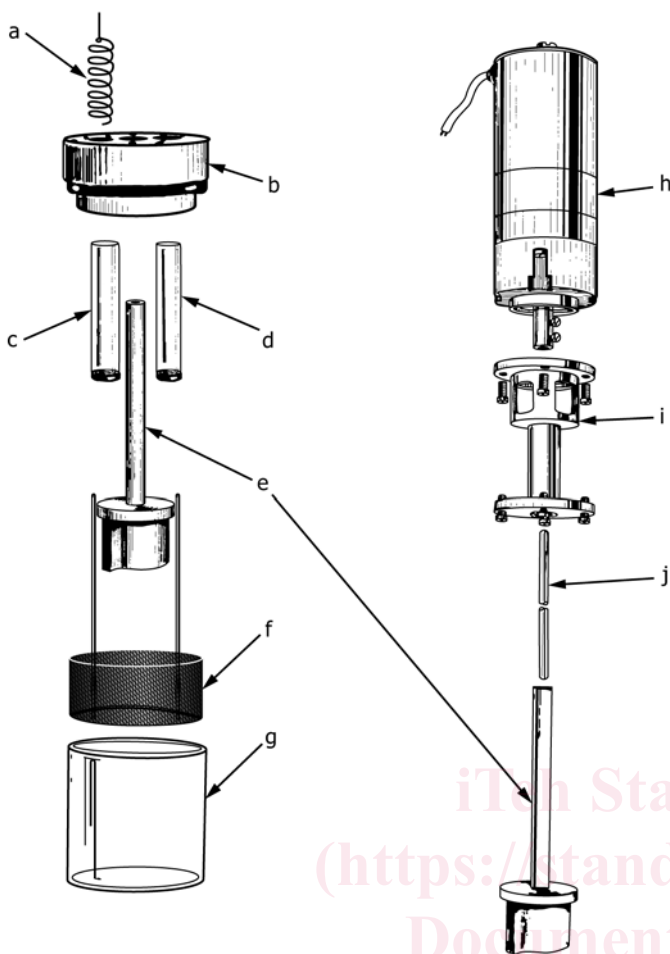

FIG. 2 Working Electrode (Top View)

FIG. 1 Exploded View of Cell Assembly: (a) Counter Electrode, (b) Cell Head, (c) Counter Electrode Frit Tube, (d) Reference Electrode Frit Tube, (e) NBL-Designed S-Shaped Stirrer, (f) Working Electrode, (g) Sample Cell, (h) Stirrer Motor, (i) Motor Pedestal and Bearing, and (j) Stirrer Shaft

Open-loop response d-c gain	>10 ⁵
Unity-gain bandwidth	>300 kHz
Full-power response	>10 kHz (slewing rate 0.5 V/μs)
Voltage zero offset stability	>1-mV long term
Input d-c resistance	>50 MΩ
Input d-c current	<50 nA
d-c control voltage span	±4 V
Resolution, hum, and drift	<1 mV
Stability through extreme of line and load variation	±5 mV
Digital Integrator (14)	
Nonlinearity of V/F converter	<0.01 % full scale
Full scale set-point	adjustable to ±0.01 % of full scale
Input offset voltage set-point	adjustable to ±0.01 % of full scale
Output readability	<1 μg Pu
Integrating capacity	>10 C
Bias	<0.01 %

6.2 *Digital Voltmeter*, 15-V range, 5½ digits accurate to 0.01 % of full scale on all ranges. Input resistance >10¹⁰ Ω.⁶

6.3 *Cell Assembly*—The success of controlled-potential coulometric methods is strongly dependent on the design of the cell. The cell dimensions, electrode area, spacing, and stirring

rate are important parameters in a design that will minimize the time required for titration. The following components are required for the recommended cell assembly (Fig. 1).

6.3.1 *Cell*—The coulometry cell is fabricated from a cut-off 50-mL borosilicate glass beaker with an inside diameter of 38 mm and a height of 42 mm; the cut edges are rounded and polished smooth. Other cells conforming to these dimensions are satisfactory.

6.3.2 *Counter Electrode and Salt Bridge Tube*—The counter electrode is a coiled length of 0.51-mm (0.020-in.) diameter platinum wire. The salt bridge tube is unfired high-silica glass⁷ filled with the supporting electrolyte solution.

6.3.3 *Reference Electrode and Salt Bridge Tube*—The reference electrode is a miniature saturated-calomel electrode (SCE).⁸ The salt bridge is identical to the salt bridge described in 6.3.2 and is also filled with supporting electrolyte solution.

6.3.4 *Working Electrode*, fabricated from either 8Au8-5/0 expanded annealed-gold metal or from 45-mesh platinum gauze (Fig. 2).

⁷ Either a test tube with unfired Vycor bottoms of Type 7930 glass obtained from Corning Glass Works, or a 0.5 cm long, 0.5-cm diameter rod of unfired Vycor Type 7930 sealed into one end of a glass tube with heat-shrinkable TFE-fluorocarbon tubing, has been found satisfactory for this application.

⁸ A Fisher Calomel Reference Electrode Catalog No. 13-639-79 has been found satisfactory.

⁶ A Hewlett-Packard 3455A DVM has been found to exceed these specifications.

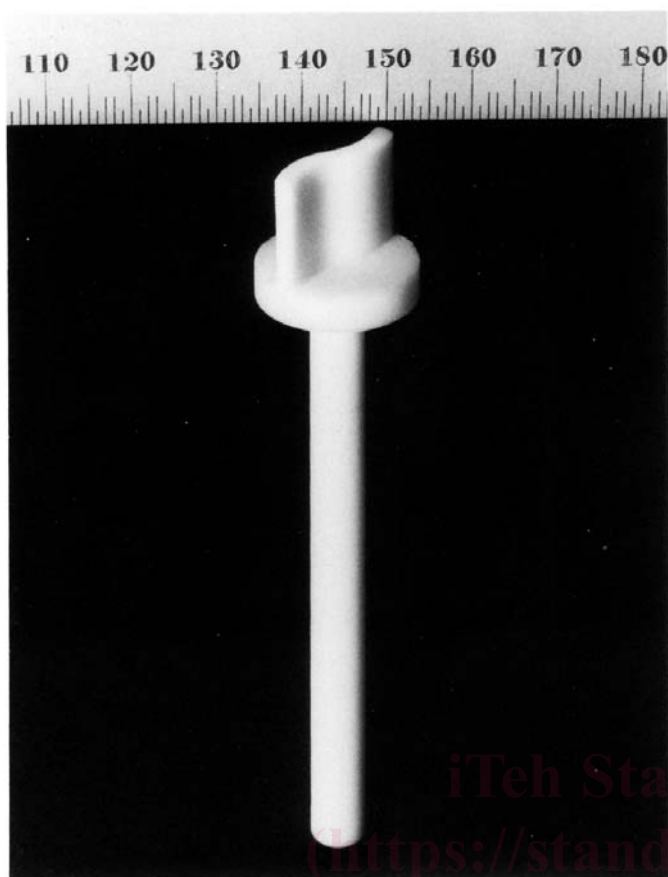

FIG. 3 S-Shaped Stirrer

6.3.4.1 Store and condition the working electrode in accordance with instruction in Section 10.

6.3.5 *Stirrer*—Several types of stirrers have performed satisfactorily. A paddle-type stirrer capable of being driven at 1800 r/min by a synchronous motor, or a magnetically driven stirring bar, is adequate. Magnetic stirring slightly simplifies the arrangement of the cell cap. For optimum stirring efficiency with freedom from losses due to splashing, an S-shaped polytetrafluoroethylene stirrer (Fig. 3) (15) driven by synchronous motor is recommended.

6.3.6 *Inert Gas Inlet Tube*—A polyvinyl chloride tube, approximately 3 mm in outside diameter (1 mm in inside diameter), is inserted so that its tip is about 10 mm above the surface of the electrolyte solution. The gas flow is adjusted so that the surface of the solution is depressed almost 3 mm. The gas is high-purity argon. While inert gas is not required for all electrolytes, it is recommended for this procedure.

6.4 *Quartz Heating Lamps*—Optimum heating or evaporating efficiency without bumping of solutions, or both, is obtained using overhead heating with quartz heat lamps⁹ controlled by a variable power supply. However, with proper care, other conventional means of heating may be used.

⁹ Quartz heating lamps and Quartz epiradiator lamps, Model 534 RCL, 500 watts, 120 V (Atlas Electric Supplies, P.O. Box 1300, Hialeah, Florida, 33011) have been found to be satisfactory.

6.5 *Hot Plate*—Recommended for heating during the plutonium oxidation state adjustment with hydrogen peroxide.

6.6 *Quartz Clock Timer*, accurate to 0.001 s.

6.7 *100-Ω Precision Resistor*, accurate to better than 0.01 %.¹⁰

7. Reagents and Materials

7.1 *Purity of Reagents*—Reagent grade chemicals shall be used in all tests. Unless otherwise indicated, it is intended that all reagents conform to the specifications of the Committee on Analytical Reagents of the American Chemical Society where such specifications are available.¹¹ Other grades may be used, provided it is first ascertained that the reagent is of sufficiently high purity to permit its use without lessening the accuracy of the determination.¹²

7.2 *Argon*, greater than 99.99 % purity.

7.3 *Hydrochloric Acid*, concentrated hydrochloric acid (HCl, specific gravity 1.19).

7.4 *Hydrochloric Acid (1 M)*, prepare by diluting 85 mL of hydrochloric acid to 1 L with water.

7.5 *Hydrochloric Acid-Nitric Acid-Hydrofluoric Acid Mixture (5.4 M HCl-1.6 M HNO₃-0.014 M HF)*—Prepare by slowly adding 450 mL hydrochloric acid, 100 mL nitric acid, and 10 drops hydrofluoric acid to 450 mL water in a polytetrafluoroethylene beaker. Cool and store in a tetrafluoroethylene (TFE) fluorocarbon bottle.

7.6 *Hydrofluoric Acid*, concentrated hydrofluoric acid (HF, 48 %).

7.7 *Hydrogen Peroxide*, 30 % solution of hydrogen peroxide (H₂O₂).

7.8 *Nitric Acid*, concentrated nitric acid (HNO₃, specific gravity 1.42).

7.9 *Nitric Acid (8 M)*—Prepare by diluting 500 mL nitric acid to 1 L with water.

7.10 *Nitric Acid (0.9 M)*—Prepare by diluting 57 mL of nitric acid to 1 L with water.¹³

7.11 *Perchloric Acid (1 M)*—Prepare by diluting 85 mL of perchloric acid (HClO₄, specific gravity 1.76) to 1 L with water.

7.12 *Plutonium Standard Solution*—Dissolve plutonium metal (NBL CRM 126, current issue) in an Erlenmeyer flask by slow addition of approximately 30 mL of hydrochloric acid-nitric acid-hydrofluoric acid mixture. Add 30 mL of 8 M

¹⁰ A Julie 100-Ω precision resistor number NB102A, accurate to 0.0015 %, has been found satisfactory.

¹¹ *Reagent Chemicals, American Chemical Society Specifications*, American Chemical Society, Washington, DC. For suggestions on the testing of reagents not listed by the American Chemical Society, see *Analar Standards for Laboratory Chemicals*, BDH Ltd., Poole, Dorset, U.K., and the *United States Pharmacopeia and National Formulary*, U.S. Pharmacopeial Convention, Inc. (USPC), Rockville, MD.

¹² All reagents should be prepared with 18-MΩ-cm deionized (demineralized) water.

¹³ 0.9 M HNO₃ is used because the range from 0.8 to 1.0 M HNO₃ provides a stable formal potential for the Pu³⁺/Pu⁴⁺ couple.