



Designation: ~~D140/D140M~~—09 D140/D140M – 14

Standard Practice for Sampling Bituminous Materials¹

This standard is issued under the fixed designation D140/D140M; the number immediately following the designation indicates the year of original adoption or, in the case of revision, the year of last revision. A number in parentheses indicates the year of last reapproval. A superscript epsilon (ϵ) indicates an editorial change since the last revision or reapproval.

This standard has been approved for use by agencies of the U.S. Department of Defense.

1. Scope

- 1.1 This practice applies to the sampling of bituminous materials at points of manufacture, storage, or delivery.
- 1.2 The values stated in either SI units or inch-pound units are to be regarded separately as standard. The values stated in each system may not be exact equivalents; therefore, each system shall be used independently of the other. Combining values from the two systems may result in non-conformance with the standard.
- 1.3 *This standard does not purport to address all of the safety concerns, if any, associated with its use. It is the responsibility of the user of this standard to establish appropriate safety and health practices and determine the applicability of regulatory limitations prior to use.*

2. Referenced Documents

- 2.1 *ASTM Standards*:²
[D346 Practice for Collection and Preparation of Coke Samples for Laboratory Analysis](#)

3. Significance and Use

- 3.1 Sampling is as important as testing, and precautions shall be taken to obtain samples to show the true nature and condition of the materials.
- 3.2 Samples are taken for either of the following two purposes:
 - 3.2.1 To represent as nearly as possible an average of the bulk of the materials sampled, or
 - 3.2.2 To ascertain the maximum variation in characteristics which the material possesses.

4. Precautions

- 4.1 Because of the numerous types and grades of bituminous materials that are alternately shipped and stored in the same or similar containers, the opportunity for contaminating these containers with residues, precipitates, or cleaning solvents is ever present. Numerous opportunities also exist for obtaining samples which are not strictly representative of the material or are contaminated after removal. Therefore, it is incumbent upon the producer, transporter, user, and sampler to exercise continuous precaution in the sampling and handling of these materials.

5. Selection of Samples

- 5.1 Whenever practicable, bituminous materials shall be sampled at the point of manufacture or storage, and at such time as to allow the tests controlling acceptance or rejection to be made in advance of shipment.
- 5.2 When the samples cannot be taken at the point of manufacture or storage, they shall be taken from the shipment immediately upon delivery.

6. Size of Samples

- 6.1 The sample size of liquid materials shall be as follows:

¹ This practice is under the jurisdiction of ASTM Committee D04 on Road and Paving Materials and is the direct responsibility of Subcommittee D04.30 on Methods of Sampling.

Current edition approved June 1, 2009; June 1, 2014. Published July 2009; June 2014. Originally approved in 1922. Last previous edition approved in 2007 as ~~D140—01 (2007):D140/D140M—09~~. DOI: ~~10.1520/D0140—D0140M—09~~; 10.1520/D0140_D0140M-14.

² For referenced ASTM standards, visit the ASTM website, www.astm.org, or contact ASTM Customer Service at service@astm.org. For *Annual Book of ASTM Standards* volume information, refer to the standard's Document Summary page on the ASTM website.



6.1.1 For routine laboratory ~~examination, examination~~ and from barrels or drums, 500 mL to 1 L [1 qt] ~~(emulsions 4 L [1 gal]); pt to 1 qt].~~

6.1.2 From bulk storage, 4 L [1 gal], ~~or gal].~~

6.1.3 ~~From barrels or drums, For emulsified products,~~ 1 L [1 qt].

6.2 The sample size of semisolid or solid materials shall be as follows:

6.2.1 From barrels, drums, or cakes, 1 to 2 kg [2 to 3 lb], ~~or lb].~~

6.2.2 From crushed or powdered material in bulk or bags, 1 to 2 kg [2 to 3 lb].

7. Containers

7.1 Type of Containers:

7.1.1 Containers for liquid bituminous materials, except emulsions, shall be wide-mouth cans with lined screw caps or triple-seal friction-top cans.

7.1.2 Containers for emulsified bituminous materials shall be wide-mouth jars or bottles made of plastic, or wide-mouth plastic-lined cans with lined screw caps, or plastic-lined triple-seal friction-top cans.

7.1.3 Containers for crushed or powdered bituminous materials shall be triple-seal friction-top cans or plastic sacks placed in other containers suitable for handling.

7.2 Size of Containers: ~~Containers—~~

7.2.1 ~~The size of the container shall correspond to the required amount of sample.~~ The size of the container shall correspond to the required sample size.

8. Protection and Preservation of Samples

8.1 Sample containers shall be new. They shall not be washed or rinsed, or wiped with an oily cloth. If they contain evidence of solder flux, or if they are not clean and dry, they shall not be used. Top and container shall fit together tightly.

8.2 Care shall be taken to prevent the sample from becoming contaminated. Immediately after filling, the container shall be tightly and positively sealed.

8.3 The filled sample container shall not be submerged in solvent, nor shall it be wiped with a solvent saturated cloth. If cleaning is necessary use a clean dry cloth.

8.4 Samples of ~~emulsions emulsified asphalt~~ shall be protected from freezing by correct packaging.

NOTE 1—When sampling ~~emulsions, emulsified asphalt,~~ care should be taken not to sample material under pressure as such resultant velocities tend to cause air entrapment which could result in erroneous test results. Any visual bubbling of the material is one indication air has been entrapped. In addition, the sampling container should be completely filled to minimize a skin formation at the air-emulsion interface.

8.5 Samples shall not be transferred from one container to another except where required by the sampling procedure.

8.6 Immediately after filling, sealing, and cleaning, the sampling containers shall be properly marked for identification with a suitable marking pencil on the container itself, and not on the lid. Labels or tags also may be used for identification if they can be securely fastened to the container in such a manner as to ensure that they will not be lost in transit. Labels or tags shall not be attached to containers by using the lids to secure them. All identification materials shall maintain their integrity at temperatures up to 200°C [390°F].

8.6.1 The labeling of the sample must, at a minimum, include an identification of the product or material type and the date of sampling.

9. Sampling at Place of Manufacture

9.1 *Vertical Tanks Not Capable of Being Agitated (Liquid Materials or Materials Made Liquid by Heating)* (800 m³ [5000 bbl] or more capacity)—Three sampling methods are recommended (Note 2):

9.1.1 *Sampling-Valve Method*—Valves shall be located, with easy and safe access provided, on the side of the tank with the first in the top third of the tank, but no higher than 1 m [3 ft] from the top; the second in the middle third of the tank; and the third in the bottom third of the tank, but no lower than 1.1 m [3 ft] from the bottom. A recommended design of the sampling valve is shown in Fig. 1.

9.1.1.1 A minimum of 4 L [1 gal] of the product shall be drawn from each sample valve and discarded before taking the sample for test, and

9.1.1.2 ~~One 500 mL~~ to 4 L [1 qt] to 1 gal shall be drawn from each sample valve for test.

9.1.2 *Thief Sampler Method* (not suitable for asphalt cements)—Samples shall be taken in the top, middle, and lower sections at levels indicated in 9.1.1, of the tank by lowering a thief sampler into the material. A satisfactory type with instructions for use is shown in Fig. 2.

NOTE 2—Most bituminous materials in the liquid state are of such viscous and adhesive character that, after normal emptying of a container by pouring, the container retains enough material to cause significant contamination of any second samples secured before the container was thoroughly cleaned. The aforementioned properties of bituminous materials also make container cleaning a difficult, tedious, and time-consuming task.



D140/D140M - 14

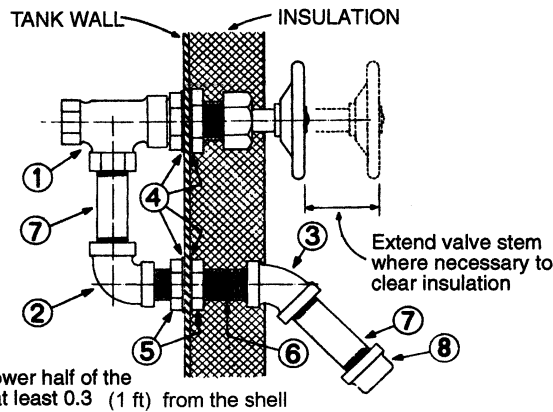

REF. NO.	DESCRIPTION	NO. REQ.
1	20 MM (3/4 IN.) 'VOGT' P-9844 STEEL ANGLE VALVE OR SIMILAR, PANEL MOUNTED	1
2	20 MM (3/4 IN.) STEEL OR MALL. IRON 1.6 RAD ELBOW	1
3	20 MM (3/4 IN.) STEEL OR MALL. IRON 0.8 RAD ELBOW	1
4	ASBESTOS GASKETS SNUG ON THREAD OR WOUND WITH YARN	4
5	20 MM (3/4 IN.) 150# SCREWED M.I. LOCKNUT	2
6	20 X 90 MM (3/4 X 3 1/2 IN.) ± PARALLEL THREADED STEEL PIPE NIPPLE (CUT FROM 20 MM (3/4 IN.) STD. TANK NIPPLE IF OTHERWISE UNOBTAINABLE)	1
7	20 X 75 MM (3/4 X 3 IN.) THREADED STEEL PIPE NIPPLE	2
8	20 MM (3/4 IN.) MALL. IRON PIPE CAP	1

FIG. 1 Typical Submerged Sampling Device

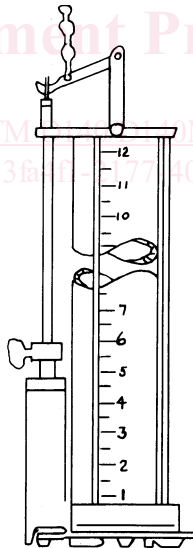

NOTE 1—This type sampler is lowered into the tank with bottom valve open (there is no top closure). When the desired depth is reached, the lowering chain is given a snap tug which closes the bottom valve. The sampler is then withdrawn from the tank and the contents transferred to the sample container. This sampler may be used for repetitive sampling in the same tank.

FIG. 2 Thief Sampler

NOTE 3—The thief sampler described in Fig. 2 may be used for repetitive sampling because significant sample contamination by previous contents is avoided by the self-cleaning action provided by the passage of material through the tube-shaped thief sampler which is open at both ends. The practice of raising and lowering the sampler 3 or 4 times through a distance of a metre (several feet) at the sampling depth is recommended.

9.1.3 *Throw-Away Container Method*—Samples shall be taken at top, middle, and lower levels by lowering into the material a container in a suitable weighted holding device. The essential feature of the method is to use a clean container to take the sample, pour this sample into another clean container, and throw away the container used to take the sample from the tank. A satisfactory type with instructions on how to use the device is shown in Fig. 3.