INTERNATIONAL STANDARD



3465

INTERNATIONAL ORGANIZATION FOR STANDARDIZATION • МЕЖДУНАРОДНАЯ ОРГАНИЗАЦИЯ ПО СТАНДАРТИЗАЦИИ • ORGANISATION INTERNATIONALE DE NORMALISATION

Hand taper pin reamers

Alésoirs à main pour trous de goupilles coniques

First edition — 1975-08-15

iTeh STANDARD PREVIEW
(standards.iteh.ai)

[ISO 3465:1975](https://standards.iteh.ai/catalog/standards/sist/e36d689d-e58e-4f0e-ae54-5ba580a42342/iso-3465-1975)

<https://standards.iteh.ai/catalog/standards/sist/e36d689d-e58e-4f0e-ae54-5ba580a42342/iso-3465-1975>

FOREWORD

ISO (the International Organization for Standardization) is a worldwide federation of national standards institutes (ISO Member Bodies). The work of developing International Standards is carried out through ISO Technical Committees. Every Member Body interested in a subject for which a Technical Committee has been set up has the right to be represented on that Committee. International organizations, governmental and non-governmental, in liaison with ISO, also take part in the work.

Draft International Standards adopted by the Technical Committees are circulated to the Member Bodies for approval before their acceptance as International Standards by the ISO Council.

International Standard ISO 3465 was drawn up by Technical Committee ISO/TC 29, *Small tools*, and circulated to the Member Bodies in June 1974.

It has been approved by the Member Bodies of the following countries :

Australia	India	South Africa, Rep. of
Austria	Israel	Spain
Belgium	Italy	Switzerland
Canada	Japan	Thailand
Chile	Mexico	Turkey
Czechoslovakia	Netherlands	United Kingdom
France	Norway	U.S.S.R.
Germany	Poland	Yugoslavia
Hungary	Romania	

The Member Bodies of the following countries expressed disapproval of the document on technical grounds :

Sweden
U.S.A.

Hand taper pin reamers

iTeh STANDARD PREVIEW (standards.iteh.ai)

1 SCOPE AND FIELD OF APPLICATION

This International Standard lays down the dimensions of hand taper pin reamers.

It covers only metric dimensions, which are the only recommended dimensions in the future for these types of reamers.

The reamers have been designed to produce holes for taper pins manufactured to ISO 2339, in the range 0,6 to 50 mm nominal diameter.

Unless otherwise stated these reamers will be right-hand cutting.

The flutes may be straight or left-hand spiral at the option of the manufacturer.

Machine taper pin reamers with parallel shanks are dealt with in ISO 3466, and machine taper pin reamers with Morse taper shanks in ISO 3467.

2 REFERENCES

ISO 237, *Rotating tools with parallel shanks – Diameters of shanks and sizes of driving squares.*

ISO/R 286, *ISO System of limits and fits – Part 1 : General, tolerances and deviations.*

ISO 2339, *Taper pins (unhardened) – Metric series.*

ISO 3466, *Machine taper pin reamers with parallel shanks.*

ISO 3467, *Machine taper pin reamers with Morse taper shanks.*

3 DRIVING SQUARES

The dimensions of the driving squares for hand taper pin reamers shall be in accordance with ISO 237 as appropriate for the shank diameter.

4 DIMENSIONS

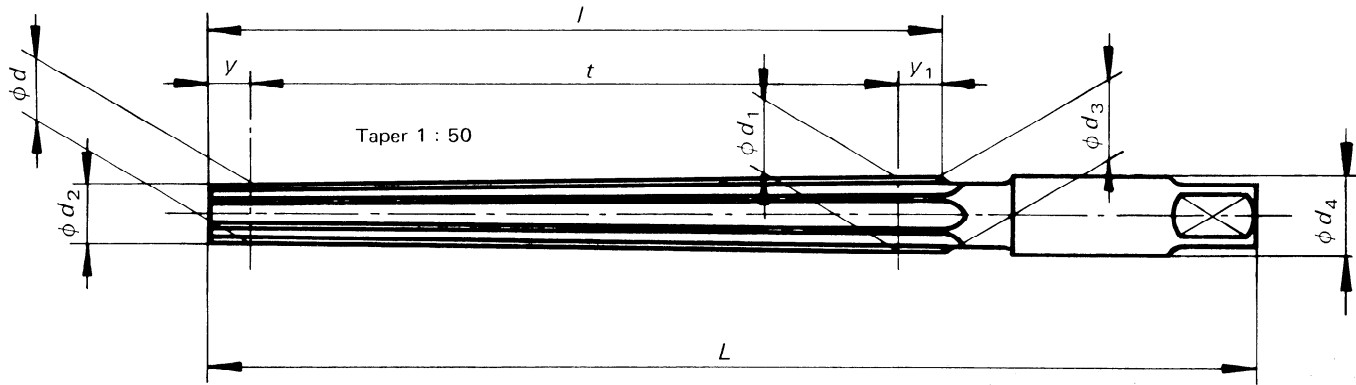

Dimensions in millimetres

d nominal	d_1	t	y	y_1	d_2	d_3	l	d_4 h 11	L
0,6	0,76	8	5	7	0,5	0,90	20	3,15	38
0,8	1,04	12	5	7	0,7	1,18	24	3,15	42
1,0	1,32	16	5	7	0,9	1,46	28	3,15	46
1,2	1,60	20	5	7	1,1	1,74	32	3,15	50
1,5	2,00	25	5	7	1,4	2,14	37	3,15	57
2,0	2,70	35	5	8	1,9	2,86	48	3,15	68
2,5	3,20	35	5	8	2,4	3,36	48	3,15	68
3,0	3,90	45	5	8	2,9	4,06	58	4,0	80
4,0	5,10	55	5	8	3,9	5,26	68	5,0	93
5,0	6,20	60	5	8	4,9	6,36	73	6,3	100
6,0	7,80	90	5	10	5,9	8,00	105	8,0	135
8,0	10,60	130	5	10	7,9	10,80	145	10,0	180
10,0	13,20	160	5	10	9,9	13,40	175	12,5	215
12,0	15,60	180	10	20	11,8	16,00	210	14,0	255
16,0	20,00	200	10	20	15,8	20,40	230	18,0	280
20,0	24,40	220	10	20	19,8	24,80	250	22,4	310
25,0	29,80	240	15	45	24,7	30,70	300	28,0	370
30,0	35,20	260	15	45	29,7	36,10	320	31,5	400
40,0	45,60	280	15	45	39,7	46,50	340	40,0	430
50,0	56,00	300	15	45	49,7	56,90	360	50,0	460