



Standard Test Methods for Vacuum Cleaner Hose—Durability and Reliability (All-Plastic Hose)¹

This standard is issued under the fixed designation F 595; the number immediately following the designation indicates the year of original adoption or, in the case of revision, the year of last revision. A number in parentheses indicates the year of last reapproval. A superscript epsilon (ϵ) indicates an editorial change since the last revision or reapproval.

1. Scope

1.1 These test methods cover the determination of the effect of anticipated stresses and strains that vacuum cleaner hoses will receive in normal use.

1.2 These test methods apply to all-plastic, nonelectric vacuum cleaner hoses for household use.

NOTE 1—For information on plastic wire-reinforced, nonelectric vacuum cleaner hoses for household use, refer to Test Method F 450.

1.3 These test methods are individual tests as agreed upon between the hose manufacturer and the vacuum cleaner manufacturer.

1.4 The following tests are included:

	Section
Torsional flex	6
Hot and cold flex with aging (optional)	7
Abrasion (external surface) (optional)	8
Flex	9
Pull test on hose fittings with aging	10
Crush	11

1.5 The values stated in inch-pound units are to be regarded as standard. The values given in parentheses are mathematical conversions to SI units, which are provided for information only and are not considered standard.

1.6 *This standard does not purport to address all of the safety concerns, if any, associated with its use. It is the responsibility of the user of this standard to establish appropriate safety and health practices and determine the applicability of regulatory limitations prior to use.*

2. Referenced Documents

2.1 ASTM Standards:

D 638 Test Method for Tensile Properties of Plastics²

D 695 Test Method for Compressive Properties of Rigid Plastics²

F 395 Terminology Relating to Vacuum Cleaners³

¹ These methods are under the jurisdiction of ASTM Committee F11 on Vacuum Cleaners, and are the direct responsibility of Subcommittee F11.30.02 on Durability/Reliability Essential Components.

Current edition approved Sept. 10, 2001. Published November 2001. Originally published as F 595 – 76. Last previous edition F 595 – 96.

² Annual Book of ASTM Standards, Vol 08.01.

³ Annual Book of ASTM Standards, Vol. 15.08.

F 450 Test Methods for Vacuum Cleaner Hose for Durability and Reliability (Plastic Wire Reinforced)⁴

3. Terminology

3.1 Definitions

3.1.1 Refer to Terminology F 395.

4. Significance and Use

4.1 These test methods can be used by buyers of vacuum cleaner hose to specify the test criteria the hose must meet to be acceptable for their purposes.

5. Sampling

5.1 The sample size shall be one that is mutually agreed upon between the hose manufacturer and the vacuum cleaner manufacturer.

TEST METHODS

6. Torsional Flex

6.1 *Scope*—This test method covers the determination of resistance to failure while twisting under stress in a bend.

6.2 *Apparatus*—The apparatus shown in Fig. 1 is suitable for this test method with the following provisions:

6.2.1 Means to rotate test mandrels in an inverted vertical position at 30 ± 2 rpm, one clockwise and the other counter-clockwise operating at identical rates.

6.2.2 Suitable clamp to attach both ends of sample hose to mandrels without causing failure at the clamp during the test.

6.2.3 Test mandrel with diameter same as inside diameter of hose with a 0.078-in. (2.0-mm) radius at the ends of the mandrel (see Fig. 1).

6.2.4 Instrument to measure cycles to failure or to a specified end point.

6.3 *Test Specimen*—The specimen shall be a length of hose 30 ± 1 in. (762 ± 25 mm) long without fittings.

6.4 *Conditioning*—Condition the specimen at 68 to 81°F (20 to 27°C) ambient temperature for not less than 1 h prior to the test.

6.5 *Procedure*:

⁴ Annual Book of ASTM Standards, Vol 15.07.

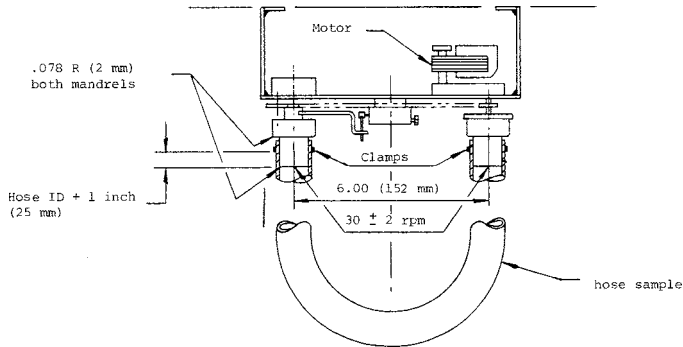

FIG. 1 Schematic for Torsional Flex Test

- 6.5.1 Conduct the tests at 68 to 81°F (20 to 27°C).
- 6.5.2 Clamp both ends of the test specimen to the test mandrels as shown in Fig. 1.
- 6.5.3 Set the measuring instrument at zero or record initial reading.
- 6.5.4 Test the specimen by rotating at 30 ± 2 rpm until failure or to a specified end point.
- 6.5.5 Failure may be evidenced by a broken reinforcing wire, tear, or hole that penetrates the hose jacket, or a collapsed coil or ply for a lined-type hose, or any combination thereof.
- 6.6 Report—The report shall include the following:
 - 6.6.1 Number of cycles to failure or to a specified end point, whichever occurs first,
 - 6.6.2 Type of failure,
 - 6.6.3 Ambient temperature,
 - 6.6.4 Description of specimen, and
 - 6.6.5 Number of specimens tested.

7. Hot and Cold Flex with Aging (Optional)

- 7.1 Scope—This test method covers the determination of the effect of temperature and flexing upon a hose sample.
- 7.2 Apparatus:
 - 7.2.1 Air-Circulating Oven or Environmental Chamber, to maintain 156°F (69°C) controlled to ±2°F (±1°C).
 - 7.2.2 Cold Box, able to maintain 20°F (-6.7°C) controlled to ±1°F (±0.5°C).
- 7.3 Test Specimen—The specimen shall be a length of hose in which the length in inches or millimetres shall be determined as follows:

$$11.2 \times \text{inside diameter, in inches,} + 2 \text{ in.}$$

$$(11.2 \times \text{inside diameter, in millimetres,} + 51 \text{ mm})$$

- 7.4 Conditioning—Condition the specimens at an ambient temperature of 68 to 81°F (20 to 27°C) for not less than 1 h prior to test.
- 7.5 Procedure:
 - 7.5.1 Bend a specimen in a “U” shape and tie the ends together at a position 1 in. (25 mm) from the ends as shown in Fig. 2.
 - 7.5.2 Place the specimen into the oven, which has been brought to a steady test temperature of 156 ± 2°F (69 ± 1°C), and soak the specimen for 20½ h.
 - 7.5.3 Remove the specimen from the oven and allow 30 min for it to come to equilibrium with the ambient temperature in accordance with 7.4.

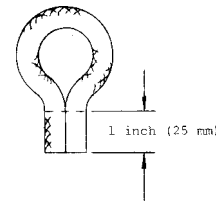

FIG. 2 Hose Position During Heat and Cold Soak

- 7.5.4 Next place the specimen in the cold box, which has been brought to a steady temperature of 20 ± 1°F (-6.7 ± 0.5°C) for 2 h.
- 7.5.5 Remove the specimen from the cold box, untie, and immediately flex it 360 deg, three times, 1 s per flex, as shown in Fig. 3.
- 7.5.6 Failure may be evidenced by a broken reinforcing wire, tear, or hole that penetrates the hose jacket, or a collapsed coil or ply for a lined-type hose, or any combination thereof.
- 7.5.7 Retie the hose in its original position.
- 7.5.8 Allow 1 h for conditioning as specified in 7.4 before starting the next cycle.
- 7.5.9 Consider the steps covered in 7.5.1-7.5.7 as one cycle. Conduct four complete, successive cycles; then permit the specimens to remain at ambient conditions for the unused balance of a 7-day period. Repeat until failure occurs or until a specified end point is reached, whichever occurs first.
- 7.6 Report—The report shall include the following:
 - 7.6.1 Number of cycles to failure or to a specified end point, whichever occurs first,
 - 7.6.2 Condition of the specimen,
 - 7.6.3 Ambient test temperature,
 - 7.6.4 Description of specimen, and
 - 7.6.5 Number of specimens tested.

8. Abrasion—External Surface (Optional)

- 8.1 Scope—This test method covers measurement of the wear characteristics of a vacuum cleaner hose subjected to an abrasive surface.
- 8.2 Apparatus:
 - 8.2.1 Special Abrasion Test Fixture, as described in Fig. 4 to produce a rate of 20 ± 1 cycles/min.
 - 8.2.2 Cylindrical Segment, as described in Fig. 5.
 - 8.2.3 Test Weight, 16 ± 0.1 oz (454 ± 2.8 g) with provision to attach to the specimen.

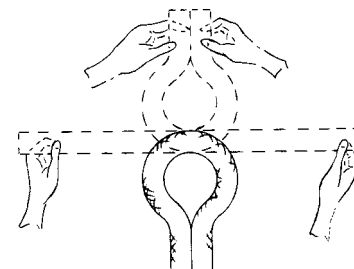
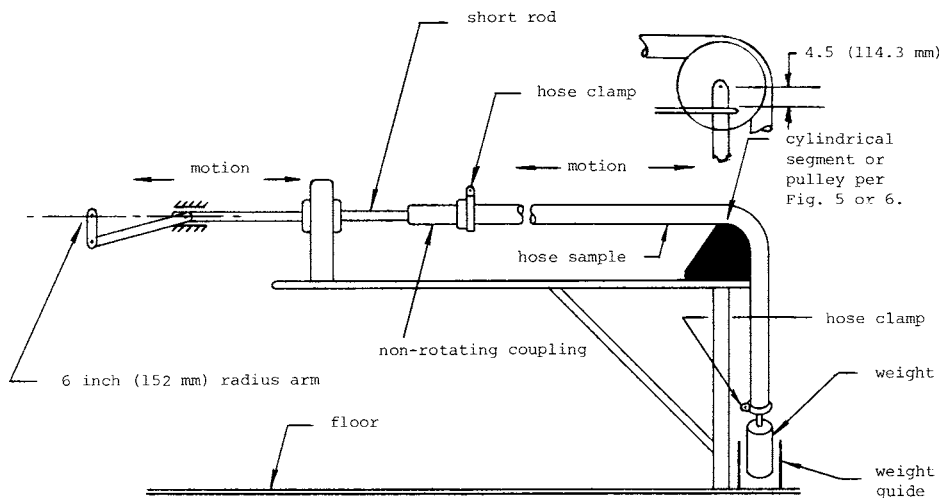

FIG. 3 Hose Flex Cycle



NOTE 1—Abrasion set up shown.
FIG. 4 Abrasion and Flex Test Fixture

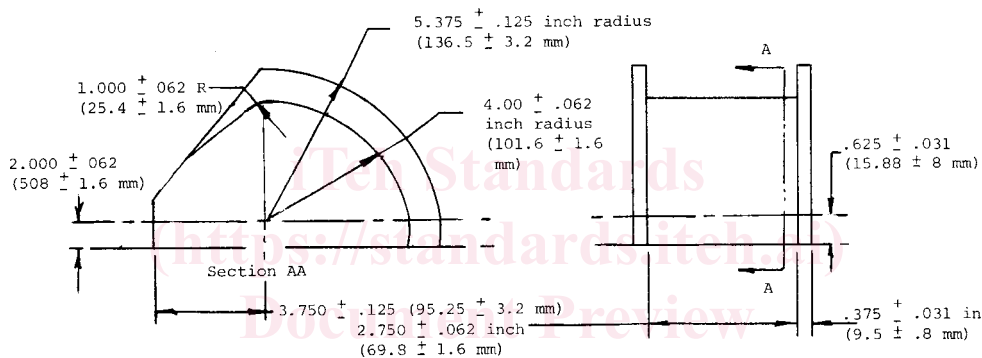

FIG. 5 Cylindrical Segment (Abrasion Test)

ASTM F595-01

8.2.4 *Abrasive Paper*, wet-dry, 500-grit, for abrasion test surface.⁵

8.2.5 *Instrument*, to measure cycles to failure or to a specified end point.

8.2.6 *Weight Guide*, to prevent weight from swinging during test cycling.

8.2.7 *Clamps*, suitable for attaching the hose to the mechanism coupling on one end and attaching the weight to the other end without causing failure of the hose at these clamps.

8.3 *Test Specimen*—The specimen shall be a full-length hose, or a length of hose suitable for the test unit.

8.4 *Conditioning*—Condition the specimen at 68 to 81°F (20 to 27°C) ambient temperature for not less than 1 h prior to test.

8.5 *Procedure*:

8.5.1 Conduct the tests at 68 to 81°F (20 to 27°C).

8.5.2 Clamp a new sheet of standard wet-dry, 500-grit, abrasive paper to the cylinder.

8.5.3 Clamp the specimen to the mechanism coupling. Attach the weight and place in the weight guide. The weight shall be in free suspension throughout the cycle.

8.5.4 Set the measuring instrument to zero or record the initial reading.

8.5.5 Cycle the specimen against the surface of the abrasive paper until failure of the jacket or to a specified end point.

8.5.6 Failure is a hole in jacket.

8.6 *Report*—The report shall include the following:

8.6.1 Number of cycles to failure or to a specified end point, whichever occurs first,

8.6.2 Description of failure,

8.6.3 Ambient test temperature,

8.6.4 Description of specimen, and

8.6.5 Number of pieces tested.

9. Flex

9.1 *Scope*—This test method covers the determination of the vacuum cleaner hose's resistance to bending under an applied stress.

9.2 *Apparatus*:

9.2.1 Same mechanism described in 8.2.1 and Fig. 4, except driving arm rotating at 36 ± 1 cycles/min and cylindrical segment replaced with pulley.

9.2.2 *Pulley*, cold-rolled, steel grooved, as described in Fig. 6.

9.2.3 *Test Weight*, 80 ± 1 oz (2268 ± 28 g) with provision to attach to the specimen.

⁵ Wet-dry, 500-grit, Tri-M-Ite abrasive paper, available from 3M Co., St. Paul, MN, has been found suitable for this purpose.