

INTERNATIONAL
STANDARD

ISO
3471

First edition
1994-02-01

**Earth-moving machinery — Roll-over
protective structures — Laboratory tests
and performance requirements**

iTeh STANDARD PREVIEW

*Engins de terrassement — Structures de protection au retournement —
Essais de laboratoire et critères de performance*

[ISO 3471:1994](#)

<https://standards.iteh.ai/catalog/standards/sist/78a7b786-402c-4e6f-a1eb-2e9b67987641/iso-3471-1994>



Reference number
ISO 3471:1994(E)

Foreword

ISO (the International Organization for Standardization) is a worldwide federation of national standards bodies (ISO member bodies). The work of preparing International Standards is normally carried out through ISO technical committees. Each member body interested in a subject for which a technical committee has been established has the right to be represented on that committee. International organizations, governmental and non-governmental, in liaison with ISO, also take part in the work. ISO collaborates closely with the International Electrotechnical Commission (IEC) on all matters of electrotechnical standardization.

Draft International Standards adopted by the technical committees are circulated to the member bodies for voting. Publication as an International Standard requires approval by at least 75 % of the member bodies casting a vote.

International Standard ISO 3471 was prepared by Technical Committee ISO/TC 127, *Earth-moving machinery*, Subcommittee SC 2, *Safety requirements and human factors*.

This first edition of ISO 3471 cancels and replaces the first edition of ISO 3471-1 published in 1986 (see the Introduction).

Annex A forms an integral part of this International Standard.

© ISO 1994

All rights reserved. Unless otherwise specified, no part of this publication may be reproduced or utilized in any form or by any means, electronic or mechanical, including photocopying and microfilm, without permission in writing from the publisher.

International Organization for Standardization
Case Postale 56 • CH-1211 Genève 20 • Switzerland

Printed in Switzerland

Introduction

This edition of ISO 3471 is a revision of ISO 3471-1:1986 as a single Standard rather than a series of parts of ISO 3471. It has been expanded to include most earth-moving machines.

A review of the initial work on the ROPS criteria indicated that the criteria were based on requirements for machines now identified as mid-range size machines. Over a period of 20 years, since the ROPS criteria were established, both smaller and larger machines have become common within the size range of earth-moving machines. Thus it was necessary to change the criteria for the lower and upper mass machines.

The criteria are a combination of linear, with respect to mass, and exponential, with respect to mass. For small machines, the exponential criterion has been changed to a linear function with respect to machine mass. For larger machines, the exponential criterion was excessive at very large machine masses and thus was changed to become a linear function with respect to machine mass.

A second criterion of longitudinal force was added as a new generation of ROPS designers became active, some of the early expertise that was developed through the process of establishing the criteria being lost. Situations could arise where ROPS designs would meet the lateral and vertical loading requirements, but yet be considered to lack sufficient performance capability in the longitudinal load direction. For this reason this International Standard now incorporates a ROPS longitudinal force criterion. The longitudinal force criterion was established at 80 % of the lateral force requirement.

iTeh STANDARD PREVIEW
This page intentionally left blank
(standards.iteh.ai)

[ISO 3471:1994](#)

<https://standards.iteh.ai/catalog/standards/sist/78a7b786-402c-4e6f-a1eb-2e9b67987641/iso-3471-1994>

Earth-moving machinery — Roll-over protective structures — Laboratory tests and performance requirements

1 Scope

This International Standard establishes a consistent and reproducible means of evaluating the load-carrying characteristics of Roll-Over Protective Structures (ROPS) under static loading, and prescribes performance requirements for a representative specimen under such loading.

It applies to the following seated design operator-controlled machines as defined in ISO 6165:

- crawler tractors and loaders;
- graders;
- wheeled loaders and wheeled tractors and their modified versions used for rolling or compacting, dozer-equipped wheeled tractors, skid-steer loaders and backhoe loaders;
- wheeled industrial tractors;
- the tractor portion (prime mover), of tractor scrapers, water wagons, articulated steer dumpers, bottom-dump wagons, side-dump wagons, rear-dump wagons and towed fifth-wheel attachments;
- rollers and compactors;
- rigid frame dumpers.

2 Normative references

The following standards contain provisions which, through reference in this text, constitute provisions of this International Standard. At the time of publication, the editions indicated were valid. All standards are subject to revision, and parties to agreements

based on this International Standard are encouraged to investigate the possibility of applying the most recent editions of the standards indicated below. Members of IEC and ISO maintain registers of currently valid International Standards.

ISO 148:1983, *Steel — Charpy impact test (V-notch)*.

ISO 898-1:1988, *Mechanical properties of fasteners — Part 1: Bolts, screws and studs*.

ISO 898-2:1992, *Mechanical properties of fasteners — Part 2: Nuts with specified proof load values — Coarse thread*.

ISO 3164:1992, *Earth-moving machinery — Laboratory evaluations of roll-over and falling-object protective structures — Specifications for deflection-limiting volume*.

ISO 6165:1987, *Earth-moving machinery — Basic types — Vocabulary*.

ISO 9248:1992, *Earth-moving machinery — Units for dimensions, performance and capacities, and their measurement accuracies*.

3 Definitions

For the purposes of this International Standard, the following definitions apply.

3.1 wheeled industrial tractor: Self-propelled machine designed to provide drawbar and/or PTO power to implements for landscaping and site services at earth-moving job sites.

3.2 roll-over protective structure (ROPS): System of structural members whose primary purpose is to reduce the possibility of a seat-belted operator being

crushed should the machine roll over. Structural members include any subframe, bracket, mounting, socket, bolt, pin, suspension or flexible shock absorber used to secure the system to the machine frame, but exclude mounting provisions that are integral with the machine frame.

3.3 machine frame: Main chassis or main load-bearing member(s) of the machine which extend(s) over a major portion of the machine and upon which the ROPS is directly mounted.

3.4 rollbar ROPS: One- or two-post ROPS without FOPS or any cantilevered load-carrying structural members.

3.5 bedplate: Substantially rigid part of the test fixtures to which the machine frame is attached for the purpose of the test.

3.6 deflection-limiting volume (DLV): Orthogonal approximation of a large, seated, male operator wearing normal clothing and a hard hat. (See ISO 3164:1992, figure 1.)

3.7 representative specimen: ROPS, mounting hardware and machine frame (complete or partial) for test purposes that is within the manufacturer's specifications.

3.8 load distribution device: Device used to prevent localized penetration of the ROPS members at the load application point.

3.9 load application point: Point on the ROPS structure where the test load is applied to the ROPS structure.

3.10 deflection of ROPS: Movement of the ROPS structure caused by the application of the load and measured at the load application point.

3.11 falling-object protective structure (FOPS): System of structural members arranged in such a way as to provide operators with reasonable protection from falling objects (for example, trees, rocks, small concrete blocks, tools).

3.12 simulated ground plane (SGP): Flat surface on which a machine, after rolling over, is assumed to come to rest.

3.12.1 lateral simulated ground plane (LSGP): For a machine coming to rest on its side, the plane 15° away from the DLV about the horizontal axis within the plane established in the vertical plane passing through the outermost point (see figure 4). This establishes the LSGP. The LSGP is established on an

unloaded ROPS and moves with the member to which load is applied while maintaining its 15° angle with respect to the vertical.

3.12.2 vertical simulated ground plane (VSGP): For a machine coming to rest in an upside-down position, the plane is defined by the top cross-member of the ROPS and that front (rear) part of the machine likely to come in contact with flat ground at the same time as the ROPS and capable of supporting the upside-down machine. The VSGP moves with the deformed ROPS (see figure 5).

NOTE 1 The VSGP applies only to rollbar ROPS.

4 Symbols

The following symbols and abbreviations are used in this International Standard.

4.1 U : Energy absorbed by the structure, related to the machine mass, expressed in joules.

4.2 F : Force, expressed in newtons.

4.3 M : Manufacturer's maximum recommended mass, expressed in kilograms.

4.3.1 The manufacturer's maximum recommended mass includes attachments in operating condition with all reservoirs full to capacity, tools and ROPS; it excludes towed equipment such as rollers, compactors and drawn scrapers.

4.3.2 For the tractor scraper and articulated steer dumper, it is the manufacturer's maximum recommended mass of the tractor portion (prime mover) only. In most cases it is the tractor portion, but it should be the ROPS-bearing member or ROPS-carrying part. Kingpins, hitches and articulated-steering components that attach to hitches or towed units are excluded from the mass of these machines.

4.3.3 For rigid frame dumpers, M excludes the mass of the dump body and the payload when the "ROPS only" criteria are selected. When the "body only" criteria are selected, M includes the mass of the dump body but excludes the mass of the payload.

4.3.4 For rollers and compactors, loosely contained ballast is also to be excluded from M . Soil, mud, rocks, branches, debris, etc. that commonly adhere to or lie on machines in use are not considered as part of the mass of any machine. Material dug, carried or handled in any manner is not considered part of the machine mass in determining test requirements.

4.4 L : Length of the ROPS in millimetres as expressed below.

- For a one- or two-post ROPS with a FOPS and/or cantilevered load-carrying structural members, the length, L , is that portion of the cantilevered load-carrying members which covers the vertical projection of the length of the DLV of the operator. It is measured at the top of the ROPS, from the extreme face of the ROPS post(s) to the far end of the cantilevered load-carrying members (see figure 1).
- For all other ROPS, the length, L , is the greatest total longitudinal distance between the outsides of the front and rear posts (see figure 2).

4.5 W : Width of the ROPS in millimetres as expressed below.

- For a one- or two-post ROPS with a FOPS and/or cantilevered load-carrying structural members, the width, W , is that portion of the cantilevered load-carrying members which covers the vertical projection of the width of the DLV. It is measured at the top of the ROPS, from the extreme face of the ROPS post to the far side of the cantilevered load-carrying members.
- For all other ROPS, the width, W , is the greatest total width between the outsides of the left and right ROPS posts (see figure 3).

4.6 Δ : Deflection of the ROPS, expressed in millimetres.

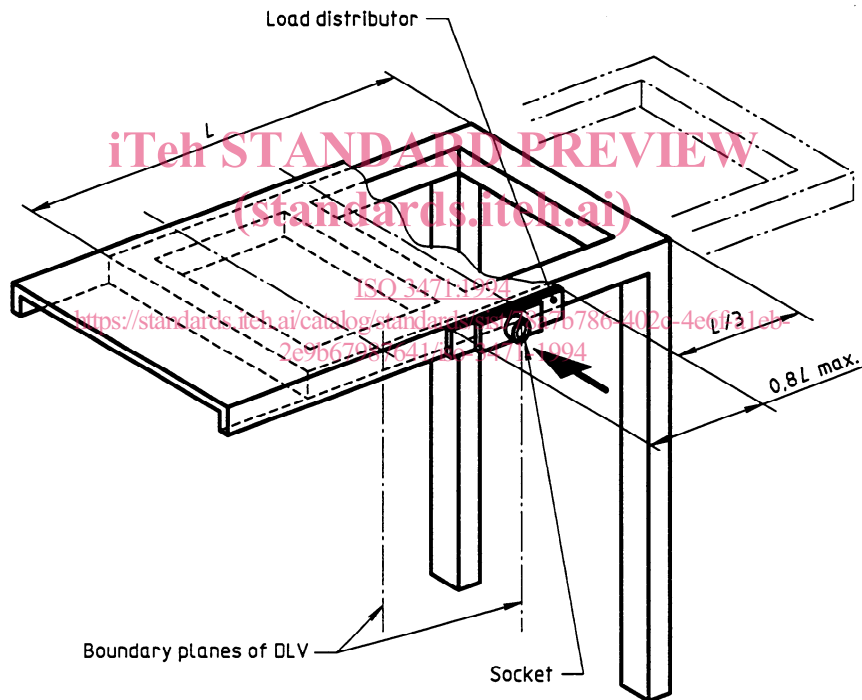

NOTE — Load distributor and socket are to prevent local penetration and to hold end of load-generating device.

Figure 1 — Two-post ROPS with FOPS lateral load application point

Dimensions in millimetres

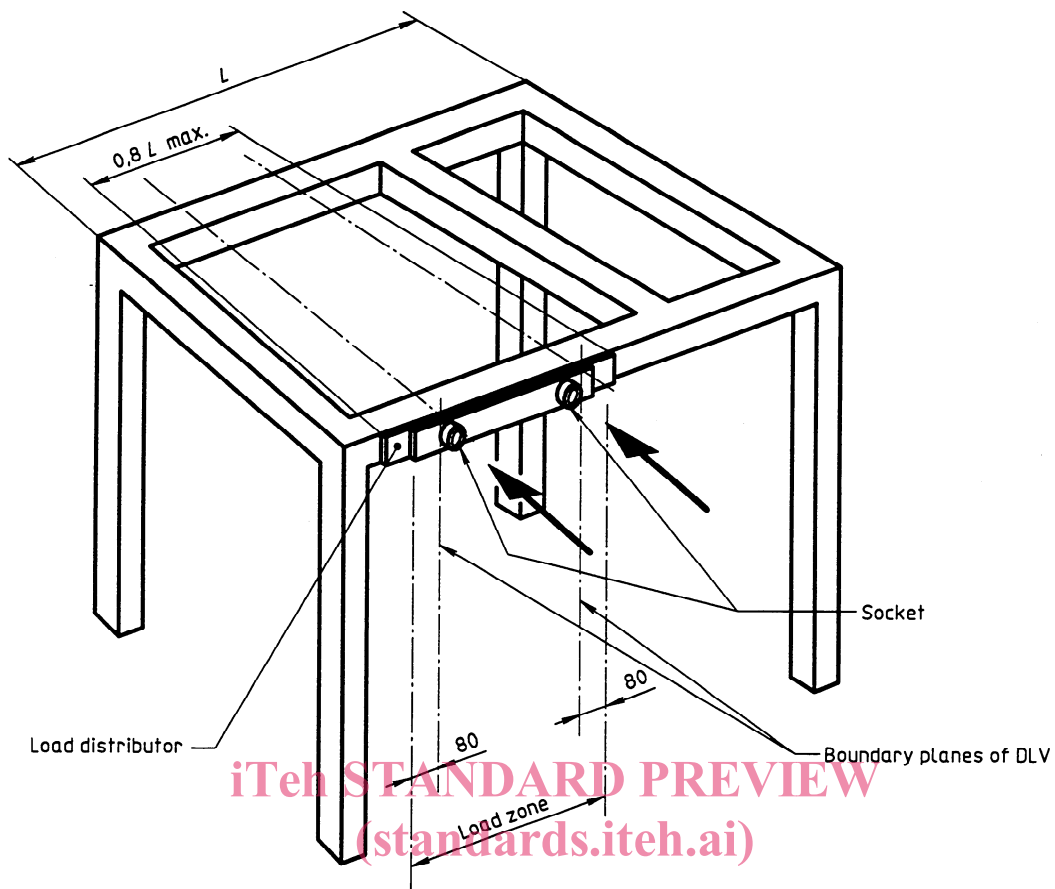

NOTES

ISO 3471:1994
<https://standards.iteh.ai/catalog/standards/sist/78a7b786-402c-4e6f-a1eb-2e9b67987641/iso-3471-1994>

- 1 Load distributor and socket are to prevent local penetration and to hold end of load-generating device.
- 2 Typical but not mandatory layout.

Figure 2 — Four-post ROPS lateral load application point

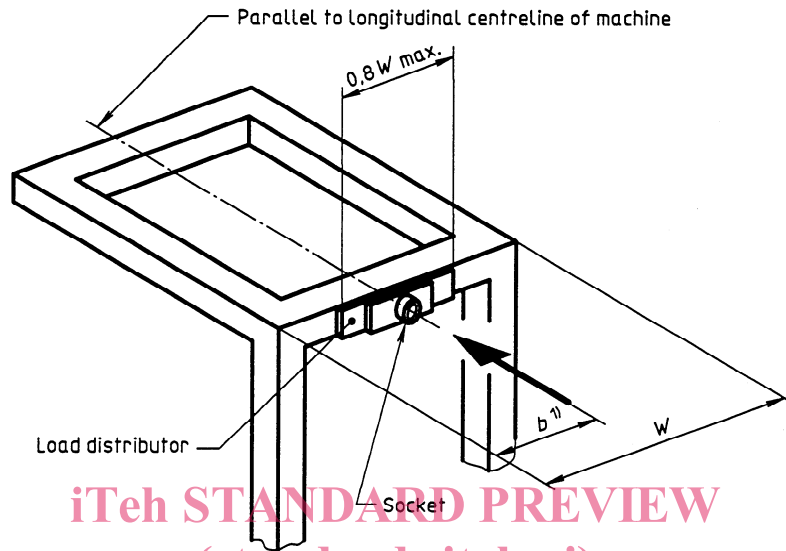

iTeh STANDARD PREVIEW
(standards.iteh.ai)

- 1) $b = W/2$ for all machines except wheeled industrial tractors.
- $b = W/4$ for wheeled industrial tractors only.

ISO 3471:1994

<https://standards.iteh.ai/catalog/standards/sist/78a7b786-402c-4e6f-a1eb-2e9b67987641/iso-3471-1994>

NOTES

- 1 Load distributor and socket are to prevent local penetration and to hold end of load-generating device.
- 2 Typical but not mandatory layout.

Figure 3 — Longitudinal load application point

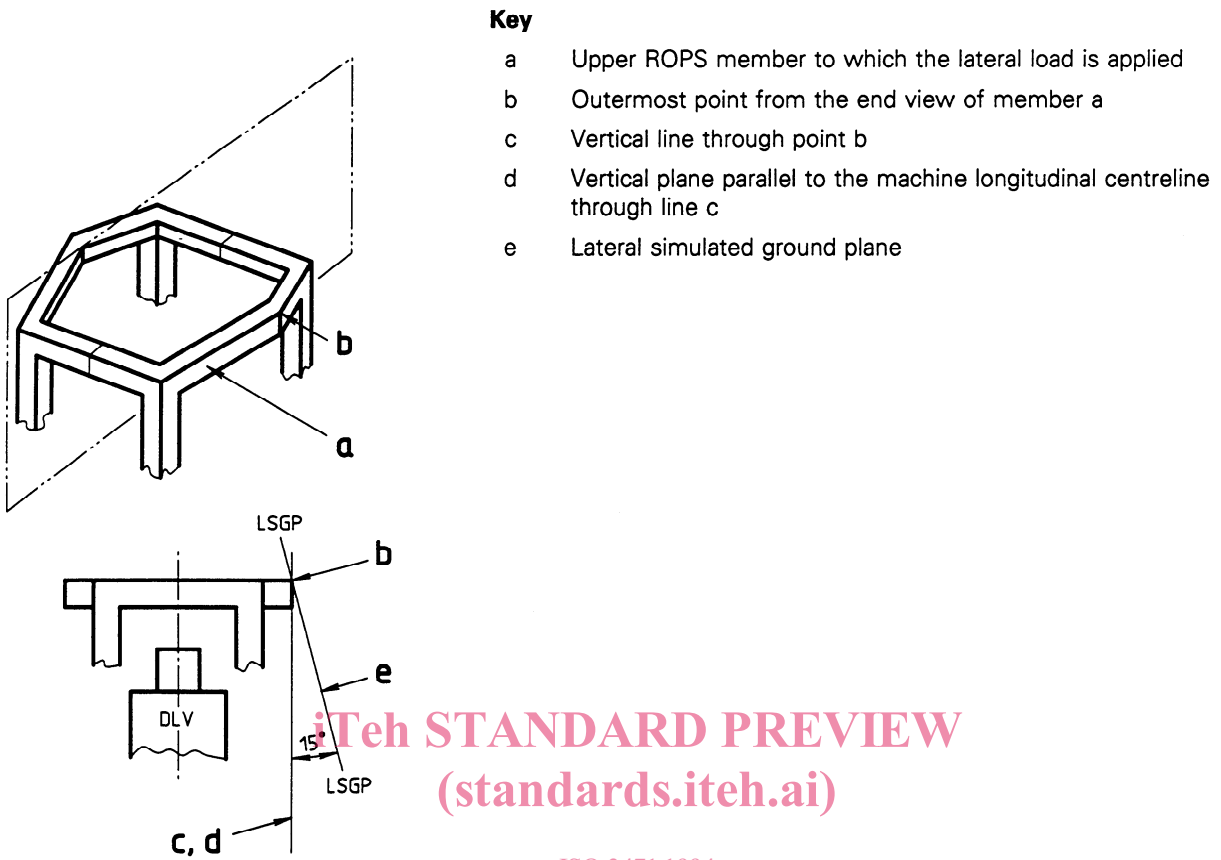

Figure 4 — Determination of lateral simulated ground plane (LSGP)

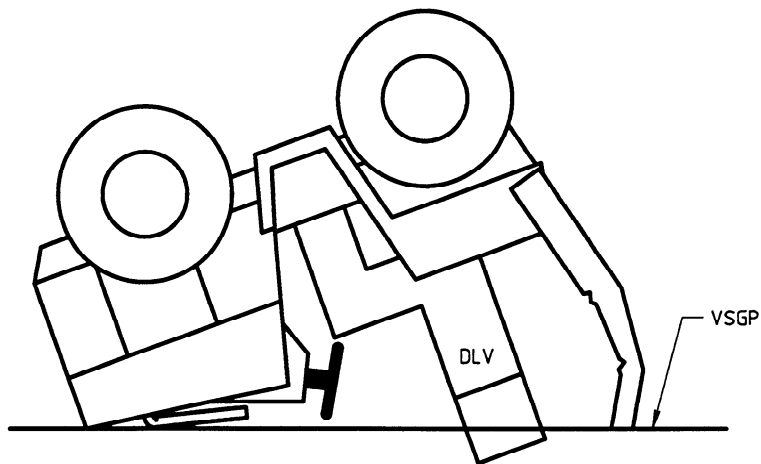

Figure 5 — Intrusion of vertical simulated ground plane (VSGP) into DLV

5 Test method and facilities

5.1 General

The requirements are force resistance in the lateral, vertical and longitudinal directions and energy absorption in the lateral direction. There are limitations on deflections under the lateral, vertical and longitudinal loading. The energy requirement and limitations on deflection (DLV) under lateral loading are intended to ensure that the ROPS will deflect when it impacts a surface which will not significantly deform (frozen ground, concrete, rock) while retaining significant capability to withstand subsequent impacts in an overturn.

The evaluation procedure will not necessarily duplicate structural deformations due to a given actual roll. However, specific requirements are derived from investigations on ROPS that have performed the intended function in a variety of actual roll-overs, as well as analytical considerations based upon the compati-

bility of ROPS and the machine frame to which it attaches. Therefore, it is expected that crush protection for a seat-belted operator will be ensured under at least the conditions of

an initial forward velocity of 0 km/h to 16 km/h on a hard clay surface of 30° maximum slope,

360° of roll about the machine longitudinal axis without losing contact with the slope.

5.2 Instrumentation

Systems used to measure mass, force and deflection shall be capable of meeting the requirements of ISO 9248.

5.3 Test facilities

Fixtures shall be adequate to secure the ROPS/machine frame assembly to a bedplate and to apply the required lateral, vertical and longitudinal loads as determined by the formulae given in table 1.

iTeh STANDARD PREVIEW (standards.iteh.ai)

[ISO 3471:1994](https://standards.iteh.ai/catalog/standards/sist/78a7b786-402c-4e6f-a1eb-2e9b67987641/iso-3471-1994)

<https://standards.iteh.ai/catalog/standards/sist/78a7b786-402c-4e6f-a1eb-2e9b67987641/iso-3471-1994>

Table 1 — Force and energy equations

Machine mass, M kg	Lateral load force, F N	Lateral load energy, U J	Vertical load force, F N	Longitudinal load force, F N
1) Crawler tractors and loaders				
$700 < M \leq 4\,630$	$6M$	$13\,000 \left(\frac{M}{10\,000} \right)^{1,25}$	$19,61M$	$4,8M$
$4\,630 < M \leq 59\,500$	$70\,000 \left(\frac{M}{10\,000} \right)^{1,2}$	$13\,000 \left(\frac{M}{10\,000} \right)^{1,25}$		$56\,000 \left(\frac{M}{10\,000} \right)^{1,2}$
$M > 59\,500$	$10M$	$2,03M$		$8M$
2) Graders				
$700 < M \leq 2\,140$	$6M$	$15\,000 \left(\frac{M}{10\,000} \right)^{1,25}$	$19,61M$	$4,8M$
$2\,140 < M \leq 38\,010$	$70\,000 \left(\frac{M}{10\,000} \right)^{1,1}$	$15\,000 \left(\frac{M}{10\,000} \right)^{1,25}$		$56\,000 \left(\frac{M}{10\,000} \right)^{1,1}$
$M > 38\,010$	$8M$	$2,09M$		$6,4M$