

---

# International Standard



# 3471/1

---

INTERNATIONAL ORGANIZATION FOR STANDARDIZATION • МЕЖДУНАРОДНАЯ ОРГАНИЗАЦИЯ ПО СТАНДАРТИЗАЦИИ • ORGANISATION INTERNATIONALE DE NORMALISATION

---

## Earth-moving machinery — Roll-over protective structures — Laboratory tests and performance requirements —

### Part 1: Crawler, wheel loaders and tractors, backhoe loaders, graders, tractor scrapers, articulated steer dumpers

*Engins de terrassement — Structures de protection au retournement — Essais de laboratoire et critères de performance —  
Partie 1: Chargeuses et tracteurs sur chenilles et sur roues, chargeuses-pelleteuses, niveleuses, décapeuses et tombereaux avec avant-train*

STANDARD PREVIEW  
(standards.iteh.ai)

First edition — 1986-06-15

[ISO 3471-1:1986](https://standards.iteh.ai/catalog/standards/sist/c597469c-05df-4187-9c36-fba3f6b59ee3/iso-3471-1-1986)

<https://standards.iteh.ai/catalog/standards/sist/c597469c-05df-4187-9c36-fba3f6b59ee3/iso-3471-1-1986>

---

UDC 621.878-788

Ref. No. ISO 3471/1-1986 (E)

**Descriptors** : earth moving equipment, loaders, tractors, graders, scrapers, dumpers, safety devices, accident prevention, overturning (vehicles), specifications, tests, laboratory tests, labelling.

## Foreword

ISO (the International Organization for Standardization) is a worldwide federation of national standards bodies (ISO member bodies). The work of preparing International Standards is normally carried out through ISO technical committees. Each member body interested in a subject for which a technical committee has been established has the right to be represented on that committee. International organizations, governmental and non-governmental, in liaison with ISO, also take part in the work.

Draft International Standards adopted by the technical committees are circulated to the member bodies for approval before their acceptance as International Standards by the ISO Council. They are approved in accordance with ISO procedures requiring at least 75 % approval by the member bodies voting.

International Standard ISO 3471/1 was prepared by Technical Committee ISO/TC 127, *Earth-moving machinery*.

**iTeh STANDARD PREVIEW**  
**(standards.iteh.ai)**

It cancels and replaces ISO 3471-1980, clause 7 and figure 5 of which have been technically revised.

<https://standards.iteh.ai/catalog/standards/sist/c597469c-05df-4187-9c36-fba3f6b59ce3/iso-3471-1-1986>

Users should note that all International Standards undergo revision from time to time and that any reference made herein to any other International Standard implies its latest edition, unless otherwise stated.

## Contents

	Page
1 Scope .....	1
2 Field of application .....	1
3 References .....	1
4 Definitions .....	2
5 Symbols .....	2
6 General .....	2
7 Static laboratory tests .....	3
8 Performance requirements .....	4
9 Labelling .....	5
10 Reporting of results .....	6
Tables 1 and 2 .....	6
Figures .....	7 to 13
<b>Annexes</b>	
A Standard test report .....	14
B Test report — Additional information for the originator of the test request .....	15

iTeh STANDARD PREVIEW  
(standards.iteh.ai)

<https://standards.iteh.ai/catalog/standards/sist/c597469c-05df-4187-9c36-1ba3f6b59ee3/iso-3471-1-1986>

**iTeh STANDARD PREVIEW**  
**(standards.iteh.ai)**

ISO 3471-1:1986

<https://standards.iteh.ai/catalog/standards/sist/c597469c-05df-4187-9c36-fba3fb59ee3/iso-3471-1-1986>

# Earth-moving machinery — Roll-over protective structures — Laboratory tests and performance requirements —

## Part 1: Crawler, wheel loaders and tractors, backhoe loaders, graders, tractor scrapers, articulated steer dumpers

### 1 Scope

#### 1.1 Part 1 of ISO 3471 sets out

- a) the static laboratory tests for measurement of structural characteristics, and
- b) the requirements for performance in a representative test,

of a roll-over protective structure (ROPS) design; it is closely related to the deflection-limiting volume (DLV) (see ISO 3164).

**1.2** The static laboratory tests are means of measuring the characteristics of the structures used to protect the operator at velocities of 0 to 16 km/h (0 to 10 mile/h) over hard clay where roll-over would be limited to a maximum roll angle of 360° down a slope of 30° maximum without penetration of the specified DLV by structural members of the ROPS.

**1.3** This part of ISO 3471 is intended to establish a consistent, reproducible means of evaluating force-deflection characteristics of ROPS under static loading and to lay down performance requirements for these structures under such loading in a representative test.

**1.4** For the purposes of this part of ISO 3471, "representative test" means a test of a specimen the material, dimensional, and processing requirements of which are typical of those ROPS being produced.

**1.5** ISO 3471/2 deals with the requirements for ROPS on machinery for forestry.

### 2 Field of application

**2.1** Part 1 of ISO 3471 applies to the following types of operator-controlled machines as defined in ISO 6165 :

- crawler loaders and wheel loaders;

- crawler tractors, wheel tractors and backhoe loaders;
- graders;
- tractor-scrappers;
- articulated steer dumpers (see ISO 7132, figures 3, 5 and 8).

**2.2** This part of ISO 3471 does not apply to :

- compactors;
- machines having a power rating less than 15 kW (20 hp);
- excavators;
- drag lines;
- rigid frame dumpers;
- pipelayers.

### 3 References

ISO 898, *Mechanical properties of fasteners —*

*Part 1: Bolts, screws and studs.*

*Part 2: Nuts with specified proof load values.*

ISO 3164, *Earth-moving machinery — Laboratory evaluation of roll-over and falling-object protective structures — Specification for the deflection-limiting volume.*

ISO 3449, *Earth-moving machinery — Falling-object protective structures — Laboratory tests and performance requirements.*

ISO 3471/2, *Earth-moving machinery — Roll-over protective structures — Laboratory tests and performance requirements — Part 2: Machinery for forestry.*<sup>1)</sup>

1) At present at the stage of draft.

ISO 6165, *Earth-moving machinery — Basic types — Vocabulary.*

ISO 7132, *Earth-moving machinery — Dumpers — Terminology and commercial specifications.*

## 4 Definitions

For the purposes of this International Standard, the following definitions apply.

**4.1 roll-over protective structure (ROPS) :** System of structural members arranged on a machine in such a way as to accomplish its primary purpose of reducing the likelihood of an operator, when wearing a seat belt, being crushed should his machine roll over. Structural members include any subframe, bracket, mounting, socket, bolt, pin, suspension or flexible shock absorber used to secure the system to the machine frame but exclude mounting provisions which are integral with the machine frame.

**4.2 machine frame :** The main chassis or main load-bearing member(s) of the machine which extend(s) over a major part of the machine and upon which the ROPS is directly mounted.

**4.3 ROPS-machine frame assembly :** The ROPS system attached to the machine frame.

**4.4 bedplate :** A substantially rigid part of the test structure to which the machine frame is attached for the purpose of the test.

**4.5 deflection-limiting volume (DLV) :** That volume, related to the operator, which serves to set limits and deflections permissible when performing laboratory evaluations of ROPS and falling-object protective structures (FOPS). The volume, an approximation, is based on the seated dimensions of the larger operator. (See ISO 3164.)

**4.6 simulated ground plane (SGP) :** Surface on which an earth-moving machine after rolling over is assumed to come to a standstill with the machine lying on its side (see 8.1.2).

## 5 Symbols

The following symbols and abbreviations are used in this International Standard.

**5.1 ROPS :** Roll-over protective structure.

**5.2  $U$  :** Energy absorbed by the structure related to the machine mass, expressed in joules or inches pounds-force.

**5.3  $F$  :** Force, expressed in newtons or pounds-force.

**5.4  $M$  :** Machine mass, expressed in kilograms (pounds).

**5.4.1** The machine mass is the manufacturer's maximum recommended mass including attachments in operating condition with all reservoirs full to capacity, tools and ROPS;

exclusive of towed equipment such as rollers, compactors, and drawn scrapers. For the tractor scraper and articulated steer dumper, it is the manufacturer's maximum recommended mass of the tractor portion only.

**5.4.2** Kingpins, hitches, and articulated steering components that attach to hitches or towed units are excluded from the mass of these machines. Soil, mud, rocks, branches, debris, etc. that commonly adhere to or lie on machines in use are not considered as part of the mass of any machine. Material dug, carried, or handled in any manner is not to be considered part of the machine mass in determining test requirements.

**5.5 DLV :** Deflection-limiting volume.

**5.6  $\Delta$  :** Deflection of ROPS, expressed in millimetres (inches).

## 6 General

The following points are stated to aid in understanding the underlying principles, intention and application of this International Standard.

**6.1** The ROPS can be integrated into the operator's cab or into the FOPS.

**6.2** This evaluation procedure will not necessarily duplicate structural deformation caused by a given actual roll.

**6.3** This evaluation procedure is generally destructive of the ROPS-machine frame assembly, as permanent deformation is apt to be induced in either or both.

**6.4** Although ROPS meeting these criteria may not give crush protection under all conceivable circumstances in which a machine could overturn, it is expected that crush protection will be ensured under at least the following conditions :

- an initial forward velocity of 0 to 16 km/h (0 to 10 mile/h) on a hard clay surface of 30° maximum slope;
- 360° of roll about the machine's longitudinal axis without losing contact with the slope and without penetration of the DLV by structural members of the ROPS.

**6.5** The horizontal force requirement and limitation on deflection (DLV) are intended to ensure that the ROPS will penetrate unfrozen soil thereby giving a braking action to a roll.

**6.6** The energy requirement and limitation on deflection (DLV) are intended to ensure that the ROPS will deflect when it strikes or impacts a surface that will not significantly deform (frozen ground, concrete, rock) while retaining significant capability to withstand subsequent impacts.

**6.7** The vertical loading requirement is intended to ensure that a deformed ROPS will be able to support the machine when it is upside-down.

**6.8** The criteria established for the deflection limitation, for the energy absorbed and for the lateral loading do not mean that the minimum side force and the minimum energy required correspond to the permissible limits of the DLV nor that they are attained simultaneously.

**6.9** The temperature-material requirements of 8.3 are intended to be a base-line of measurement for testing, to ensure that the ROPS will have meaningful resistance to brittle fracture; they do not necessarily relate to operating conditions.

**6.10** Because, in an actual roll, loading will be dynamic (possibly impact) the use of conventional "safety factors" based on static force loading should be used with caution. The "safety factor" of a ROPS is related more to energy absorption capability and details of weld design and welding procedure than it is to static force resistance.

**7 Static laboratory tests**

**7.1 Facilities**

Facilities for securing the ROPS-machine frame assembly to the bedplate, as described below, and for applying the horizontal and vertical loads shall be provided.

The DLV and its location shall be in accordance with ISO 3164. The DLV shall be fixed firmly to the same part of the machine to which the operator's seat is secured, and shall remain there during the entire formal test period.

**7.2 Instruments**

The test apparatus shall be equipped with instruments for measuring the force applied to the protective structure and the deflection (deformation) of the structure.

The percentages below are nominal ratings of the accuracy of the instrumentation and shall not be taken to indicate that compensating tests are required.

Measurement	Accuracy
Deflection of ROPS	± 5 % of maximum deflection measured
Force applied to ROPS	± 5 % of maximum force measured

**7.3 Arrangements for load application**

Typical, but not mandatory, loading arrangements are shown in the figures as follows.

**7.3.1 Wheel loaders, wheel tractors and backhoe loaders :** figures 1c), 1d).

**7.3.2 Graders :** figures 2c), 2d).

**7.3.3 Tractor scrapers and articulated steer dumpers :** figures 3c), 3d).

**7.3.4 Crawler tractors and crawler loaders :** figures 4c), 4d).

**7.3.5 Side loading :** figures 5a), 5b), 5c), 5d).

**7.4 Apparatus**

**7.4.1 General considerations**

**7.4.1.1 Assembly of the ROPS to the machine frame**

The ROPS shall be attached to the machine frame as it would be on an operating machine. A complete machine is not required for the evaluation; however, the machine frame and ROPS mounting shall represent an operating installation. All normally detachable windows, panels, doors, and other non-structural elements shall be removed so that they do not contribute to or detract from the structural evaluation.

**7.4.1.2 Attachment of the ROPS-machine frame assembly to the bedplate**

The ROPS-machine frame assembly shall be secured to the bedplate so that the members connecting the assembly and bedplate experience minimal deflection when the ROPS is horizontally loaded. During side loading, the ROPS-machine frame assembly shall not receive any support from the bedplate, other than that due to the initial attachment.

**7.4.1.3 Elimination of suspension elements and shock absorbers**

The machine frame shall be secured and/or modified so that any machine suspension element that might be considered as a suspension element (rubber, gas, gas-oil, or mechanical spring) shall be effectively eliminated as an energy absorber. However, the ROPS-structural members as defined in 4.1 may include suspension or flexible shock absorbers which shall not be altered.

**7.4.2 Specific considerations related to particular types of machine – Side loading**

**7.4.2.1 Wheel loaders, wheel tractors, backhoe loaders and graders**

Connections to the bedplate shall be directly from the machine frame at or near the front-axle support and the rear drive support. For articulated machines, if both frames are used in the evaluation, the hinge shall be locked so that the attitude of the frames is in a straight line. If only that frame on which the ROPS is mounted is used, the connections shall be at or near the extreme ends of the frame. See figures 1a), 1b), 2a), 2b).

**7.4.2.2 Tractor scrapers and articulated steer dumpers**

Connection to the bedplate shall be directly from the machine frame at or near the drive tyre or axle location. See figures 3a), 3b).

**7.4.2.3 Crawler tractors and crawler loaders**

Connection to the bedplate shall be through the main housing or track frames. See figures 4a), 4b).

**7.4.3 Vertical loading – All machines**

For vertical loading there is no limitation on securing or supporting the ROPS-machine frame assembly.

## 7.5 Procedure

### 7.5.1 General

The test procedures shall consist of the operations specified in 7.5.2 and 7.5.3, in the order listed.

No repair or straightening of any ROPS-machine member shall be carried out during or between the side and vertical loading.

### 7.5.2 Side loading

**7.5.2.1** The force-deflection characteristics shall be determined by side loading the top major longitudinal members of the ROPS.

For a ROPS having more than two posts, the side loading shall be applied through a load-distribution device having a length not greater than 80 % of the top member straight length  $L$  between the front and rear posts of the ROPS. See figures 5a), 5b), 5c). The initial loading shall be within the zone that is established by the vertical projection of two planes located 80 mm outside the front and rear planes of the DLV and parallel to the DLV planes. See figures 5a), 5b), 5c).

**7.5.2.2** For a ROPS with an overhead shield, having a two-post system, the initial loading shall be dictated by the total longitudinal distance between major, upper ROPS members ( $L$ ) and the vertical projection of the front and rear planes of the DLV. The force (load) point shall not be within  $L/3$  distance from the posts. Should the  $L/3$  point be between the vertical projection of the DLV and the posts, the force (load) point shall be moved away from the post until it enters the vertical projection of the DLV. See figure 5d). Any load distribution plate used shall not impede or restrict the rotation of the ROPS around a vertical axis during the loading and shall not distribute the load over a distance greater than 80 % of  $L$ . See figure 5d).

The force shall be applied to the major, upper and longitudinal members except when a post structure is used without the cantilevered overhead shield. For this type of structure, the force shall be applied in line with the upper cross-member.

**7.5.2.3** The initial direction of the force shall be horizontal and perpendicular to a vertical plane through the machine's longitudinal centre-line.

**7.5.2.4** As loading continues, the ROPS-machine frame deformations may cause the direction of the force to change; this is permissible.

**7.5.2.5** Should the operator's seat be off the machine's longitudinal centre-line, the loading shall be against the outermost side nearest the seat.

**7.5.2.6** For on-centre-line seats, if mounting of the ROPS is such that different force-deflection relations are obtained from loading from left or right sides, the side loaded shall be that which will place the most severe requirements on the ROPS-machine frame assembly.

**7.5.2.7** The rate of deflection (application of load) shall be such that it can be considered static.

**7.5.2.8** At deflection increments no greater than 25 mm (1 in) at the point of application of the resultant load, the force and deflection shall be recorded and plotted. See figure 6.

**7.5.2.9** The loading shall be continued until the ROPS has achieved both the force and energy requirements. The area under the resulting force-deflection curve (figure 6) equals the energy.

**7.5.2.10** The deflection(s) used in calculating energy shall be that of the ROPS along the line(s) of action of the force(s). The deflection should be measured at the mid-point of the loading. See figures 5b), 5c), 5d).

**7.5.2.11** Any deflection of members used to support load-application devices shall not be included in deflection measurements used for calculation of energy absorption.

### 7.5.3 Vertical loading

**7.5.3.1** After removal of the side load, a vertical load shall be applied to the top of the ROPS.

**7.5.3.2** There are no limitations on the manner of distributing this load on ROPS having more than two posts. See figures 1c), 1d), 2c), 2d), 3c), 3d), 4c), 4d) for typical vertical loading arrangements.

**7.5.3.3** For a ROPS having a two-post system, the vertical loading shall be dictated by the total longitudinal distance between major, upper ROPS members ( $L$ ) and the vertical projection of the front and rear planes of the DLV. The force (load) point shall be at a distance not less than  $L/3$  distance from the posts. Should the  $L/3$  point be between the vertical projection of the DLV and the posts, the force (load) point shall be moved away from the post until it enters the vertical projection of the DLV.

NOTE — The figures referred to in 7.5 are illustrative and are not intended to restrict the design of loading devices.

## 8 Performance requirements

### 8.1 General

**8.1.1** During each test, no part of the ROPS shall enter the DLV (see ISO 3164). Also, deformation of the ROPS shall not allow the SGP, as defined in 8.1.2, to enter the DLV.

NOTE — It is not required that the included volume of a ROPS having four or more vertical members entirely enclose the positioned DLV, nor is it intended that a simple (two-post) frame be excluded as a ROPS.

**8.1.2** ROPS deflection during each test shall not cause the load side planes of the DLV (figure 7) to extend beyond or intersect the SGP (see figure 7) defined as follows :

- a) upper member to which the force is applied;
- b) outermost point in end view of above member;



- c) vertical line through above point;
- d) vertical plane parallel to vehicle's longitudinal centre-line through the above line;
- e) rotate plane described in d) above, 15° away from the DLV about an axis which is perpendicular to the vertical line given in c) above and also passes through the point described in b) above; this establishes the SGP;
- f) the SGP shall be established on an unloaded ROPS and shall move with the member to which the load is applied.

10 mm × 7,5 mm specimen :	9,5 J at – 30 °C (7 ft.lbf at – 20 °F)
10 mm × 5 mm specimen :	7,5 J at – 30 °C (5,5 ft.lbf at – 20 °F)
10 mm × 2,5 mm specimen :	5,5 J at – 30 °C (4 ft.lbf at – 20 °F)

**8.1.3** The ROPS shall not break away from the machine frame due to failure of the machine frame.

## 8.2 Force-energy and vertical force requirements

**8.2.1** These requirements shall be met within the deflection(s) permitted in 8.1.1. The requirements are related to  $M$ , the machine manufacturer's "maximum recommended mass", in kilograms (pounds). See 5.4.

**8.2.2** The side-load force attained during the representative side loading test shall be at least that given by the equations set forth in table 1.

If the required force is attained or exceeded before the energy requirement is met, the force may decrease but shall attain the required force when the energy is achieved or exceeded.

**8.2.3** The energy absorbed during the representative side loading test shall be at least that given by the equations set forth in table 2.

**8.2.4** After removal of the side load, the ROPS-machine frame assembly shall support a vertical force equal to  $2M$  (the maximum recommended mass) for a period of 5 min or until any deformation has ceased, whichever is shorter.

## 8.3 Temperature and material requirements

**8.3.1** The laboratory evaluations shall be performed with all ROPS and machine frame members soaked to – 18 °C (0 °F) or below.

**8.3.2** If the evaluations are not performed at this temperature, the following minimum material requirements shall be met.

**8.3.2.1** Bolts and nuts used to attach the ROPS to the machine frame and to connect structural parts of the ROPS shall be property class 8.8 or 10.9 bolts (see ISO 898/1) and 8 or 10 property class nuts (see ISO 898/2).

**8.3.2.2** Structural members of the ROPS made from steel shall have one of the following Charpy V-notch impact strengths :

10 mm × 10 mm specimen :	10,8 J at – 30 °C (8 ft.lbf at – 20 °F)
--------------------------	--

Structural members of the ROPS made from materials other than steel shall have equivalent low temperature impact resistance.

## NOTES

- Specimens are to be "longitudinal" and taken from flat stock, tubular, or structural sections before forming or welding for use in the ROPS. Specimens from tubular or structural sections are to be taken from the middle of the side of greatest dimension and shall not include welds.
- In those countries using the inch system, the grade of bolts or nuts used shall be of an equivalent grade (i.e. equal to the ROPS material).
- The requirements of 8.3.2.2 are set forth as information until such time as ISO develops an International Standard.

**8.3.3** Materials used shall be processed in such a manner as to eliminate sharp corners and edges that are adjacent to the operator or service personnel work areas.

## 9 Labelling

**9.1** A label shall be applied to every ROPS with or without a FOPS.

### 9.1.1 Label specifications

**9.1.1.1** The label shall be of a permanent type and permanently attached to the structure.

**9.1.1.2** The label shall be located on the structure so that it can be easily read and is protected from weather defacing.

### 9.1.2 Label content

**9.1.2.1** Name and address of the manufacturer or fabricator of the ROPS (and FOPS if integral with the ROPS).

**9.1.2.2** ROPS and FOPS identification number, if any.

**9.1.2.3** Machine make, model(s), or series number(s) the structure is designed to fit.

**9.1.2.4** Maximum machine mass  $M$  for which the ROPS structure meets all of the performance requirements of this part of ISO 3471.

**9.1.2.5** The International Standard number(s) for which the structure meets all of the performance requirements (for

example, ISO 3471, ISO 3449). Other performance requirements may be included.

9.1.2.6 The manufacturer may include such other information as deemed appropriate (for example, installation, repair or replacement information).

## 10 Reporting of results

A test report shall include the results of the test and be presented in a typical test report as shown in annex A. Additional information presented in annex B shall be reported only to the test initiator.

Table 1 – Minimum force  $F$  attained during side loading

Machine	Equation	
	SI units <sup>1)</sup>	Imperial units <sup>2)</sup>
Wheel loaders, wheel tractors and backhoe loaders	$F = 60\,000 \left( \frac{M}{10\,000} \right)^{1,20}$	$F = 5\,220 \left( \frac{M}{10\,000} \right)^{1,20}$
Graders	$F = 70\,000 \left( \frac{M}{10\,000} \right)^{1,10}$	$F = 6\,600 \left( \frac{M}{10\,000} \right)^{1,10}$
Tractor scrapers and articulated steer dumpers	$F = 95\,000 \left( \frac{M}{10\,000} \right)^{1,20}$	$F = 8\,270 \left( \frac{M}{10\,000} \right)^{1,20}$
Crawler tractors and crawler loaders	$F = 70\,000 \left( \frac{M}{10\,000} \right)^{1,20}$	$F = 6\,090 \left( \frac{M}{10\,000} \right)^{1,20}$

1)  $F$  expressed in newtons  
 $M$  expressed in kilograms

2)  $F$  expressed in pounds-force  
 $M$  expressed in pounds

<https://standards.iteh.ai/catalog/standards/sist/c597469c-05df-4187-9c36-fba3f6b59ee3/iso-3471-1-1986>  
 (standards.iteh.ai)

Table 2 – Minimum energy  $U$  absorbed during side loading

Machine	Equation	
	SI units <sup>1)</sup>	Imperial units <sup>2)</sup>
Wheel loaders, wheel tractors and backhoe loaders	$U = 12\,500 \left( \frac{M}{10\,000} \right)^{1,25}$	$U = 41\,180 \left( \frac{M}{10\,000} \right)^{1,25}$
Graders	$U = 15\,000 \left( \frac{M}{10\,000} \right)^{1,25}$	$U = 49\,410 \left( \frac{M}{10\,000} \right)^{1,25}$
Tractor scrapers and articulated steer dumpers	$U = 20\,000 \left( \frac{M}{10\,000} \right)^{1,25}$	$U = 65\,880 \left( \frac{M}{10\,000} \right)^{1,25}$
Crawler tractors and crawler loaders	$U = 13\,000 \left( \frac{M}{10\,000} \right)^{1,25}$	$U = 42\,830 \left( \frac{M}{10\,000} \right)^{1,25}$

1)  $U$  expressed in joules  
 $M$  expressed in kilograms

2)  $U$  expressed in inches pounds-force  
 $M$  expressed in pounds

The arrangements shown are typical but not mandatory.

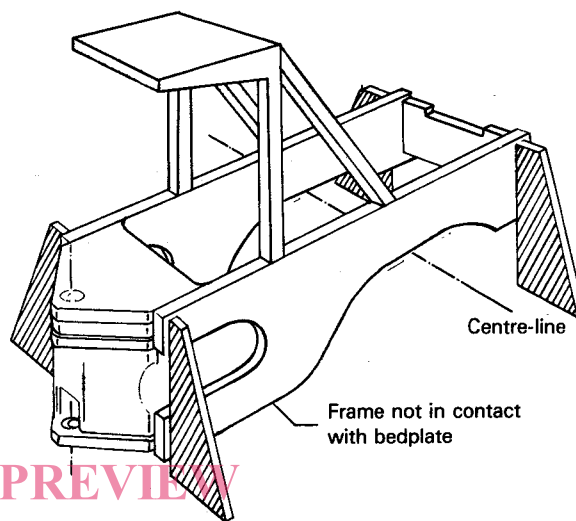
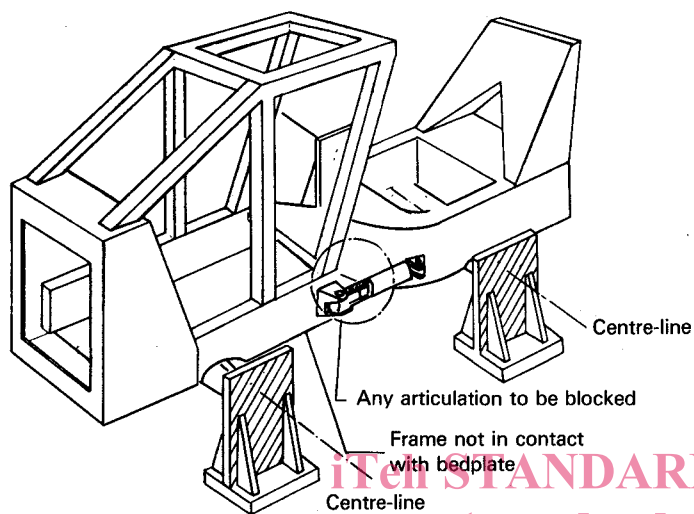

Figure 1a)

Figure 1b)

ISO 3471-1:1986

<https://standards.iteh.ai/catalog/standards/sist/c597469c-05df-4187-9c36-fba3f6b59ee3/iso-3471-1-1986>

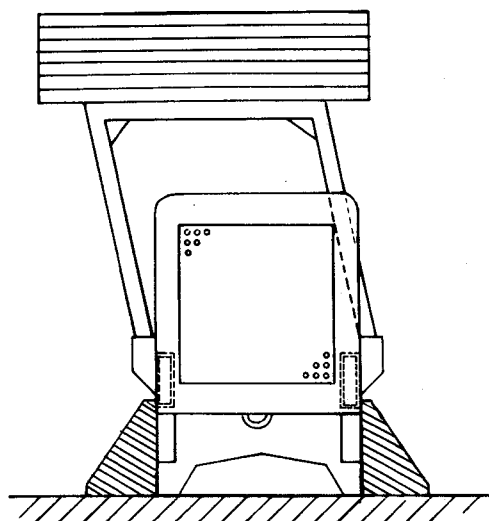

Figure 1c)

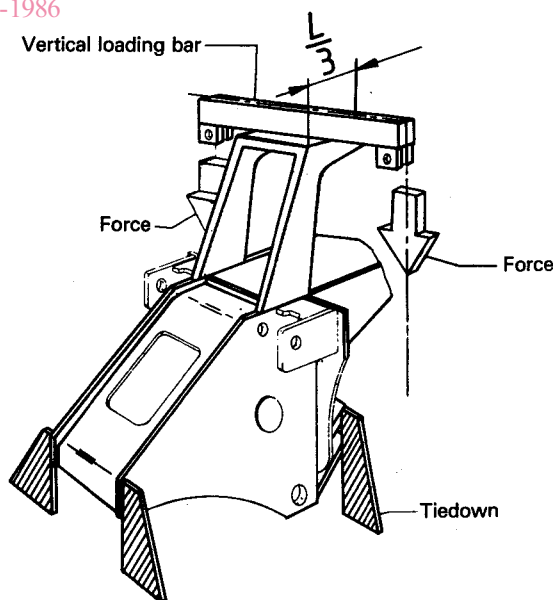

Figure 1d)

Figure 1 – Wheel loaders, wheel tractors and backhoe loaders