



Designation: ~~D4411 – 03 (Reapproved 2014)~~ **D4411 – 03 (Reapproved 2014)^{ε1}**

Standard Guide for Sampling Fluvial Sediment in Motion¹

This standard is issued under the fixed designation D4411; the number immediately following the designation indicates the year of original adoption or, in the case of revision, the year of last revision. A number in parentheses indicates the year of last reapproval. A superscript epsilon (ϵ) indicates an editorial change since the last revision or reapproval.

^{ε1} NOTE—The footnotes of Table 1 were editorially corrected in July 2014.

1. Scope

1.1 This guide covers the equipment and basic procedures for sampling to determine discharge of sediment transported by moving liquids. Equipment and procedures were originally developed to sample mineral sediments transported by rivers but they are applicable to sampling a variety of sediments transported in open channels or closed conduits. Procedures do not apply to sediments transported by flotation.

1.2 This guide does not pertain directly to sampling to determine nondischarge-weighted concentrations, which in special instances are of interest. However, much of the descriptive information on sampler requirements and sediment transport phenomena is applicable in sampling for these concentrations, and 9.2.8 and 13.1.3 briefly specify suitable equipment. Additional information on this subject will be added in the future.

1.3 The cited references are not compiled as standards; however they do contain information that helps ensure standard design of equipment and procedures.

1.4 Information given in this guide on sampling to determine bedload discharge is solely descriptive because no specific sampling equipment or procedures are presently accepted as representative of the state-of-the-art. As this situation changes, details will be added to this guide.

1.5 *This standard does not purport to address all of the safety concerns, if any, associated with its use. It is the responsibility of the user of this standard to establish appropriate safety and health practices and determine the applicability of regulatory limitations prior to use.* Specific precautionary statements are given in Section 12.

2. Referenced Documents

2.1 ASTM Standards:²

[D1129 Terminology Relating to Water](#)

[D3977 Test Methods for Determining Sediment Concentration in Water Samples](#)

3. Terminology

3.1 *Definitions*—For definitions of other terms used in this guide, see Terminology [D1129](#).

3.1.1 *isokinetic*—a condition of sampling, whereby liquid moves with no acceleration as it leaves the ambient flow and enters the sampler nozzle.

3.1.2 *sampling vertical*—an approximately vertical path from water surface to the streambed. Along this path, samples are taken to define various properties of the flow such as sediment concentration or particle-size distribution.

3.1.3 *sediment discharge*—mass of sediment transported per unit of time.

3.1.4 *suspended sediment*—sediment that is carried in suspension in the flow of a stream for appreciable lengths of time, being kept in this state by the upward components of flow turbulence or by Brownian motion.

3.2 *Definitions of Terms Specific to This Standard:*

¹ This guide is under the jurisdiction of ASTM Committee [D19](#) on Water and is the direct responsibility of Subcommittee [D19.07](#) on Sediments, Geomorphology, and Open-Channel Flow.

Current edition approved Jan. 1, 2014. Published March 2014. Originally approved in 1984. Last previous edition approved in 2003 as D4411 – 03 (2008). DOI: [10.1520/D4411-03R14](#). [10.1520/D4411-03R14E01](#).

² For referenced ASTM standards, visit the ASTM website, [www.astm.org](#), or contact ASTM Customer Service at [service@astm.org](#). For *Annual Book of ASTM Standards* volume information, refer to the standard's Document Summary page on the ASTM website.

3.2.1 *concentration, sediment*—the ratio of the mass of dry sediment in a water-sediment mixture to the volume of the water-sediment mixture. Refer to Practice D3977.

3.2.2 *depth-integrating suspended sediment sampler*—an instrument capable of collecting a water-sediment mixture isokinetically as the instrument is traversed across the flow; hence, a sampler suitable for performing depth integration.

3.2.3 *depth-integration*—a method of sampling at every point throughout a sampled depth whereby the water-sediment mixture is collected isokinetically to ensure the contribution from each point is proportional to the stream velocity at the point. This method yields a sample that is discharge-weighted over the sampled depth. Ordinarily, depth integration is performed by traversing either a depth- or point-integrating sampler vertically at an acceptably slow and constant rate; however, depth integration can also be accomplished with vertical slot samplers.

3.2.4 *point-integrating suspended-sediment sampler*—an instrument capable of collecting water-sediment mixtures isokinetically. The sampling action can be turned on and off while the sampler intake is submerged so as to permit sampling for a specified period of time; hence, an instrument suitable for performing point or depth integration.

3.2.5 *point-integration*—a method of sampling at a fixed point whereby a water-sediment mixture is withdrawn isokinetically for a specified period of time.

3.2.6 *stream discharge*—the quantity of flow passing a given cross section in a given time. The flow includes the mixture of liquid (usually water), dissolved solids, and sediment.

4. Significance and Use

4.1 This guide is general and is intended as a planning guide. To satisfactorily sample a specific site, an investigator must sometimes design new sampling equipment or modify existing equipment. Because of the dynamic nature of the transport process, the extent to which characteristics such as mass concentration and particle-size distribution are accurately represented in samples depends upon the method of collection. Sediment discharge is highly variable both in time and space so numerous samples properly collected with correctly designed equipment are necessary to provide data for discharge calculations. General properties of both temporal and spatial variations are discussed.

5. Design of the Sampling Program

5.1 The design of a sampling program requires an evaluation of several factors. The objectives of the program and the tolerable degree of measurement accuracy must be stated in concise terms. To achieve the objectives with minimum cost, care must be exercised in selecting the site, the sampling frequency, the spatial distribution of sampling, the sampling equipment, and the operating procedures.

5.2 A suitable site must meet requirements for both stream discharge measurements and sediment sampling (1).³ The accuracy of sediment discharge measurements are directly dependent on the accuracy of stream discharge measurements. Stream discharge usually is obtained from correlations between stream discharge, computed from flow velocity measurements, the stream cross-section geometry, and the water-surface elevation (stage). The correlation must span the entire range of discharges which, for a river, includes flood and low flows. Therefore, it is advantageous to select a site that affords a stable stage-discharge relationship. In small rivers and man-made channels, artificial controls as weirs can be installed. These will produce exceptionally stable and well defined stage-discharge relationships. In large rivers, only natural controls ordinarily exist. Riffles and points where the bottom slope changes abruptly, such as immediately upstream from a natural fall, serve as excellent controls. A straight uniform reach is satisfactory, but the reach must be removed from bridge piers and other obstructions that create backwater effects.

5.3 A sampling site should not be located immediately downstream from a confluence because poor lateral mixing of the sediment will require an excessive number of samples. Gaging and sampling stations should not be located at sites where there is inflow or outflow. In rivers, sampling during floods is essential so access to the site must be considered. Periods of high discharge may occur at night and during inclement weather when visibility is poor. In many instances, bridges afford the only practical sampling site.

5.4 Sampling frequency can be optimized after a review of the data collected during an initial period of intensive sampling. Continuous records of water discharge and gauge height (stage) should be maintained in an effort to discover parameters that correlate with sediment discharge, and, therefore, can be used to indirectly estimate sediment discharge. During periods of low-water discharge in rivers, the sampling frequency can usually be decreased without loss of essential data. If the sediment discharge originates with a periodic activity, such as manufacturing, then periodic sampling may be very efficient.

5.5 The location and number of sampling verticals required at a sampling site is dependent primarily upon the degree of mixing in the cross section. If mixing is nearly complete, that is the sediment is evenly and uniformly distributed in the cross section, a single sample collected at one vertical and the water discharge at the time of sampling will provide the necessary data to compute

³ The boldface numbers in parentheses refer to the list of references at the end of this standard.

instantaneous sediment-discharge. Complete mixing rarely occurs and only if all sediment particles in motion have low fall velocities. Initially, poor mixing should be assumed and, as with sampling any heterogeneous population, the number of sampling verticals should be large.

5.6 If used properly, the equipment and procedures described in the following sections will ensure samples with a high degree of accuracy. The procedures are laborious but many samples should be collected initially. If acceptably stable coefficients can be demonstrated for all anticipated flow conditions, then a simplified sampling method, such as pumping, may be adopted for some or all subsequent sampling.

6. Hydraulic Factors

6.1 *Modes of Sediment Movement:*

6.1.1 Sediment particles are subject to several forces that determine their mode of movement. In most instances where sediment is transported, flow is turbulent so each sediment particle is acted upon by both steady and fluctuating forces. The steady force of gravity and the downward component of turbulent currents accelerate a particle toward the bed. The force of buoyancy and the upward components of turbulent currents accelerate a particle toward the surface. Relative motion between the liquid and the particle is opposed by a drag force related to the fluid properties and the shape and size of the particle.

6.1.2 Electrical charges on the surface of particles create forces that may cause the particles to either disperse or flocculate. For particles in the submicron range, electrical forces may dominate over the forces of gravity and buoyancy.

6.1.3 Transport mode is determined by the character of a particle's movement. Clay and silt-size particles are relatively unaffected by gravity and buoyant forces; hence, once the particles are entrained, they remain suspended within the body of the flow for long periods of time and are transported in the suspended mode.

6.1.4 Somewhat larger particles are affected more by gravity. They travel in suspension but their excursions into the flow are less protracted and they readily return to the bed where they become a part of the bed material until they are resuspended.

6.1.5 Still larger particles remain in almost continuous contact with the bed. These particles, termed bedload, travel in a series of alternating steps interrupted by periods of no motion when the particles are part of the streambed. The movement of bedload particles invariably deforms the bed and produces a bed form (that is, ripples, dunes, plane bed, antidunes, etc.), that in turn affects the flow and the bedload movement. A bedload particle moves when lift and drag forces or impact of another moving particle overcomes resisting forces and dislodges the particle from its resting place. The magnitudes of the forces vary according to the fluid properties, the mean motion and the turbulence of the flow, the physical character of the particle, and the degree of exposure of the particle. The degree of exposure depends largely on the size and shape of the particle relative to other particles in the bed-material mixture and on the position of the particle relative to the bed form and other relief features on the bed. Because of these factors, even in steady flow, the bedload discharge at a point fluctuates significantly with time. Also, the discharge varies substantially from one point to another.

6.1.6 Within a river or channel, the sizes of the particles in transport span a wide range and the flow condition determines the mode by which individual particles travel. A change in flow conditions may cause particles to shift from one mode to the other.

6.1.7 For transport purposes, the size of a particle is best characterized by its fall diameter because this describes the particle's response to the steady forces in the transport process.

6.2 *Dispersion of Suspended Sediment:*

6.2.1 The various forces acting on suspended-sediment particles cause them to disperse vertically in the flow. A particle's upward velocity is essentially equal to the *difference* between the mean velocity of the upward currents and the particle's fall velocity. A particle's downward velocity is essentially equal to the *sum* of the mean velocity of the downward currents and the particle's fall velocity. As a result, there is a tendency for the flux of sediment through any horizontal plane to be greater in the downward direction. However, this tendency is naturally counteracted by the establishment of a vertical concentration gradient. Because of the gradient, the sediment concentration in a parcel of water-sediment mixture moving upward through the plane is higher than the sediment concentration in a parcel moving downward through the plane. This difference in concentration produces a net upward flux that balances the net downward flux caused by settling. Because of their high fall velocities, large particles have a steeper gradient than smaller particles. Fig. 1(2) shows (for a particular flow condition) the gradients for several particle-size ranges. Usually, the concentration of particles smaller than approximately 60 μm will be uniform throughout the entire depth.

6.2.2 Turbulent flow disperses particles laterally from one bank to the other. Within a long straight channel of uniform cross section, lateral concentration gradients will be nearly symmetrical and vertical concentration gradients will be similar across the section. However, within a channel of irregular cross section, lateral gradients will lack symmetry and vertical gradients may differ significantly. Fig. 2(3) illustrates the variability within one cross section of the Rio Grande.

6.2.3 Sediment entering from the side of a channel slowly disperses as it moves downstream and lateral gradients may exist for several hundred channel widths downstream. In or near a channel bend, secondary flow accentuates both horizontal and vertical gradients. Until data have been collected to prove the contrary, one must assume both gradients exist and design sampling procedures accordingly.

6.2.4 At sections where spatial variability exists, samples must be collected from many regions within a cross section. Only for special conditions will samples from one or two points be adequate.

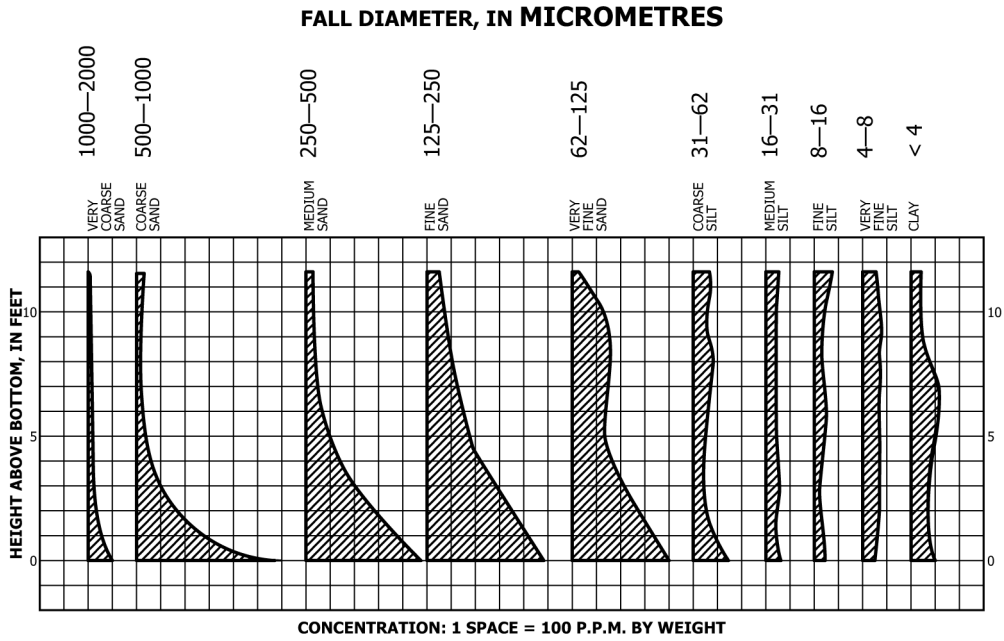

FIG. 1 (2) Vertical Distribution of Sediment in the Missouri River at Kansas City, MO

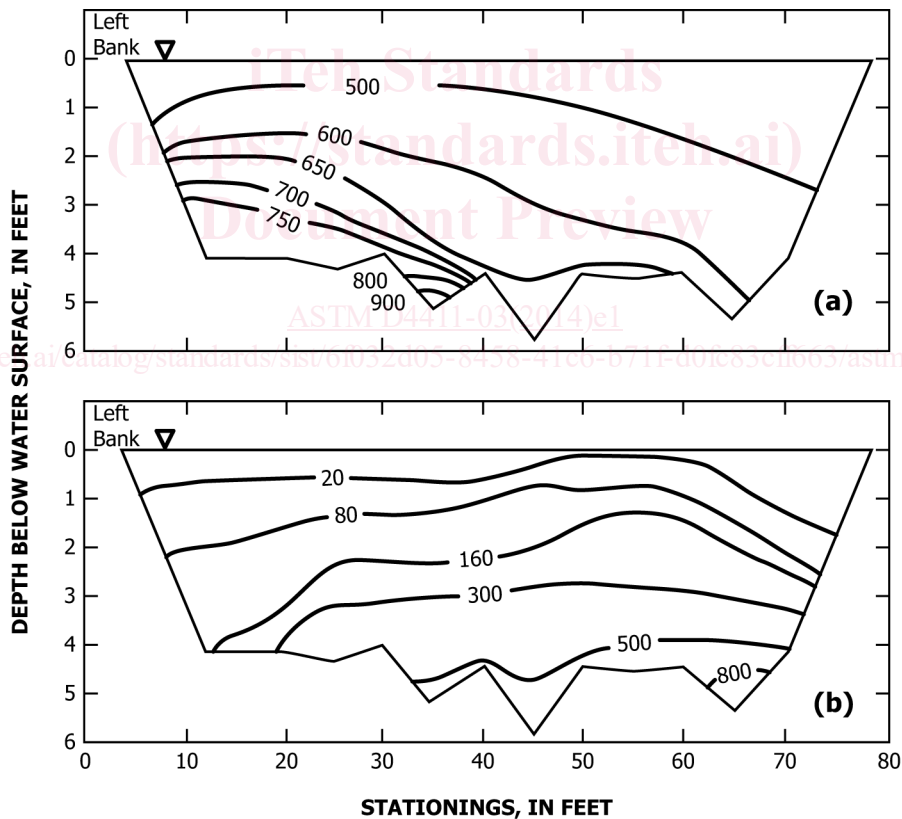

FIG. 2 (3) Cross-Sectional Variability of Suspended Material in Two Different Size Ranges, Rio Grande, near Bernardo, NM (a)(a) Contours in mg/L for Material Between 0.0625 and 0.125 mm; (b)(b) Contours in mg/L for Material Between 0.25 and 0.5 mm

6.2.5 Despite turbulent currents that disperse particles along the direction of flow, the concentration at a fixed point will vary with time even if flow conditions are steady. Temporal variability depends upon many factors. Within a group of samples collected during a short period of time, the concentration of any sample generally will not deviate from the mean by more than approximately 20 %; however, every sample must be composed of a stream filament at least 50 ft long.

7. Spatial and Temporal Variations in Bedload Discharge

7.1 Bedload discharges vary both within a section and along the channel due to variations in the sediment and mean flow properties, turbulence, patterns of secondary circulation and position relative to the bed relief. (See 13.1, also 7.2.) Also, because of the intimate relationship between bedload discharge and the flow forces, particles that move as bedload at one section may be immobile or may move as suspended load at another cross section. As a result, the proportion of bedload discharge to total sediment transport may vary longitudinally and bedload discharge observed at one section may not be representative of the bedload discharge at another section.

7.2 Although data on the temporal variation in bedload discharge are far from abundant, observations with bedload samplers have shown that discharges vary dramatically and tend to be cyclic. In one study (4) of a river having bed material of coarse cobbles, bedload samples collected every 3 min during a 3-h test showed a coefficient of variation of 41 % and an oscillation period of about seven minutes. Another study (5), conducted in a laboratory flume with a bed of coarse gravel, showed that the coefficient of variation of bedload samples collected every minute during a 1-h test was 100 %. Temporal variations at a fixed sampling point are caused, in large measure, by the passage of bed forms. Because a single measurement at a point probably will not be representative of the mean bedload discharge, numerous repetitive measurements must be made at each measurement point during a time interval that is sufficiently long to allow a number of bed-form wave-lengths to pass. Alternatively, the sampling position must be moved longitudinally so that samples are obtained randomly over parts of several bed-form wave-lengths.

8. Spatial and Temporal Variations in Total-Sediment Discharge

8.1 Temporal and spatial variations in the total sediment discharge result from the combined effects of variations in the suspended-sediment discharge and the bedload discharge. Detailed information on the extent of temporal variations in total load are scarce; however, as with variations in suspended sediment discharge, the variations in total load can be expected to change according to particle size. Ordinarily, at normal river sections, the total load cannot be measured as a separate entity; therefore, it is obtained by combining observations of the suspended load and the bedload. When the total-sediment discharge is determined from measurements of the suspended-sediment and bedload discharges, sufficient sampling must be performed to account for the temporal and spatial variations in both quantities.

8.1.1 At certain kinds of unusual sections, such as outfalls, sills and weirs, or in highly turbulent flow, all of the sediment particles may be entrained in the water; consequently, total load can be measured by sampling through the nappe or through the entire depth. Such sections are often called total-load sections. At total-load sections, spatial variations in the total sediment discharge can be significant and are functions of the lateral variations in flow properties, suspended-sediment concentration, and bedload discharge. At total-load sections, sampling must be carried out in accordance with the principles of suspended-sediment sampling and replicate samples must be collected at a sufficient number of lateral locations to account for variations in the discharge of entrained bedload particles.

9. Selection and Design of Sampling Apparatus

9.1 Apparatus selection depends upon the object of the sampling program and the physical and hydraulic characteristics of the site. To sample for total sediment discharge within a straight section of open channel, use a suspended-sediment sampler in conjunction with a bedload sampler. If initial measurements show that nearly all of the total load is transported in suspension, routine sampling can be simplified by eliminating bedload measurements. At an outfall, total load may be measured by sampling through the nappe with a depth-integrating sampler. Because these samplers are calibrated when fully submerged, the depth of the nappe should be great enough to ensure the flow contacts the region downstream of the air exhaust port. For continuous sampling of total load, a traveling-slot or a stationary-slot sampler may be used.

9.2 Suspended Sediment Samplers:

9.2.1 Whenever the fluid within a streamtube accelerates by changing either its direction or speed, sediment particles tend to migrate across the streamtube boundaries. This migration causes a local enrichment or depletion in the sediment concentration. To avoid such changes at a sampling nozzle, suspended-sediment samplers must operate isokinetically (or nearly isokinetically). If the velocity at the entrance of the sampler nozzle deviates from ambient velocity by less than $\pm 15\%$, the error in concentration will seldom exceed $\pm 5\%$. The angle between the axis of the nozzle and the approaching flow should not exceed 20° .

9.2.2 Two basic types of isokinetic instruments are commonly used to sample suspended sediment. One type (integrating) accumulates the liquid-sediment mixture by withdrawing it during a long period of time. The other type (trap) instantaneously traps a volume of the mixture by simultaneously closing off the ends of a flow-through chamber. The integrating type collects a long filament of flow, hence, the sample concentration is only slightly affected by short-term fluctuations in the concentration within the approaching flow. For this reason, integrating types are recommended over trap types.

9.2.3 For integrating-type samplers it is recommended that the nozzle entrance be circular in cross section and have an inside diameter of 4.8 mm ($3/16$ in.) or larger. At the nozzle entrance, the wall thickness should not exceed 1.6 mm ($1/16$ in.) and the outside edge should be gently rounded.

9.2.4 To ensure an undisturbed flow pattern, the nozzle must extend upstream from its support which may be a tethered body or a fixed support strut. An upstream distance of 25.4 mm (1 in.) is adequate provided the support is well streamlined and its largest dimension lateral to the flow is not more than 40 nozzle diameters.

9.2.5 After entering the nozzle, the sample must be conveyed, without a change in concentration, to a container. If the volume of the conduit is more than approximately 5 % of the sample volume, the velocity within the conduit must be adequate to ensure transport as a homogeneous suspension. A velocity exceeding 17 *W* is recommended where *W* equals settling velocity of the largest particle in suspension.

9.2.6 Integrating samplers that meet the above requirements are fabricated commercially in the United States. The samplers, which are listed in **Table 1(6)**, belong to the “US Series” designed and sold by the Federal Interagency Sedimentation Project. The samplers are of two types, depth-integrating and point-integrating.

9.2.7 *Depth-Integrating Samplers*—US Series depth-integrating samplers have an intake nozzle and exhaust port but they do not have a valve; therefore, they sample the water-sediment mixture continuously when submerged. They are highly reliable because they do not contain moving parts; furthermore, they are suitable for use in a sampling technique termed “depth integration” (see **13.1.4**). Depth-integrating samplers have a maximum operating depth (see **Table 1(6)**). **Fig. 3(7)** shows the shape of one member of the US Series of depth-integrators. Auxiliary equipment includes a cable-and-reel suspension system, or for the DH-48 (**8**) and DH-81, a wading-rod suspension. During the depth-integration process, a sampler must be lowered and raised at a uniform rate so cable-speed indicators or timing devices are used whenever possible.

9.2.8 *Point-Integrating Samplers*—US Series point-integrating samplers have an intake nozzle and exhaust port that can be opened and closed while the samplers are submerged. They also contain a pressure-equalization system to ensure that the pressure within the sample container equals the hydrostatic pressure whenever the intake-exhaust valve is opened. These features allow the samplers to be used for sampling by either the depth integration or point integration (see **13.1.3**) techniques. Maximum allowable depths listed for these samplers in **Table 1(6)** apply when they are used for point integration. When the samplers are used for depth

TABLE 1 (6) Physical Characteristics of US-Series Depth-Integrating and Point-Integrating Samplers for Collecting Samples of Water-Suspended Sediment Mixtures (after Table 3-3, National Handbook of Recommended Methods for Water-Data Acquisition)

NOTE 1—[Type: DI, depth-integrating; PI, point-integrating. Available nozzle size: A, 4.8 mm; B, 6.4 mm; C, 7.9 mm. Body material: AL, aluminum; BR, bronze; PL, plastic; FL, fluoropolymer].

Name	Type of Sampler	Method of Suspension	Mass, kg	Overall Length, m	Available Nozzle Size	Sample Container Size, mL	Maximum Allowable Depth, m	Maximum Calibrated Velocity, m/s	Distance Between Nozzle and Sampler Bottom, mm	Body Material	Remarks
US DH-48	DI	rod	2.0	0.33	A ^A , B	473	^B	2.7	90	AL	for wading.
US DH-59	DI	cable	10.2	0.42	A, B	473	^B	1.5	114	BR	for hand-line operation.
US DH-76	DI	cable	10.9	0.47	A, B	946	^B	2.0	80	BR	for hand-line operation.
US D-74	DI	cable	28.2	0.66	A, B	473 or 946	^B	2.0	103	BR	
US D-74AL	DI	cable	11.4	0.66	A, B	473 or 946	^B	1.8	111	^C	light weight US D-74.
US DH-81	DI	rod	0.8	0.3	A, B, C	1000	4.6	2.1	102	PL, FL	for wading
US DH-95	DI	cable	13.1	0.61	A, B, C	1000	4.6	2.3	122	BR	for hand-line operation
US D-95	DI	cable	29.0	0.66	A, B, C	1000	4.6	2.0	122	BR	
US D-96	DI	cable	59.9	0.89	A, B, C	3000	^C	3.8	102	BR/AL	Collapsible-bag sampler
US D-96-A1	DI	cable	36.3	0.89	A, B, C	3000	^C	1.8	102	BR/AL	Collapsible-bag sampler
US D-99	DI	cable	124.7	1.00	A, B, C	6000	^D	4.6	241	BR	Collapsible-bag sampler
US P-50	PI	cable	135.6	1.12	A	473 or 946	61.0 ^E 41.0 ^F	3.0	140	BR	
US P-61-A1	PI	cable	47.5	0.71	AAAA	473 or 946	54.9 ^E 36.6 ^F	2.0	109	BR	
US P-63	PI	cable	90.4	0.85	A	473 or 946	54.9 ^F 36.6 ^F	2.0	150	BR	
US P-72	PI	cable	17.7	0.71	A	473 or 946	22.0 ^E 15.5 ^F	1.6	109	AL	

^A 4.8-mm nozzle available by special order.

^B Varies with nozzle and container sizes as follows:

Nozzle Size	Container Size
	473 mL 946 mL
A	4.9 m 4.9 m
B	2.7 m 4.9 m

^C Varies with nozzle and container sizes as follows:

Nozzle Size	Container Size
A	33.5 m
B	18.3 m
C	11.9 m

^D Varies with nozzle and container sizes as follows:

Nozzle Size	Container Size
A	23.8 m
B	36.6 m
C	67.1 m

^E With 473-mL container.

^F With 946-mL container.

^{ε1} Aluminum body, bronze head.

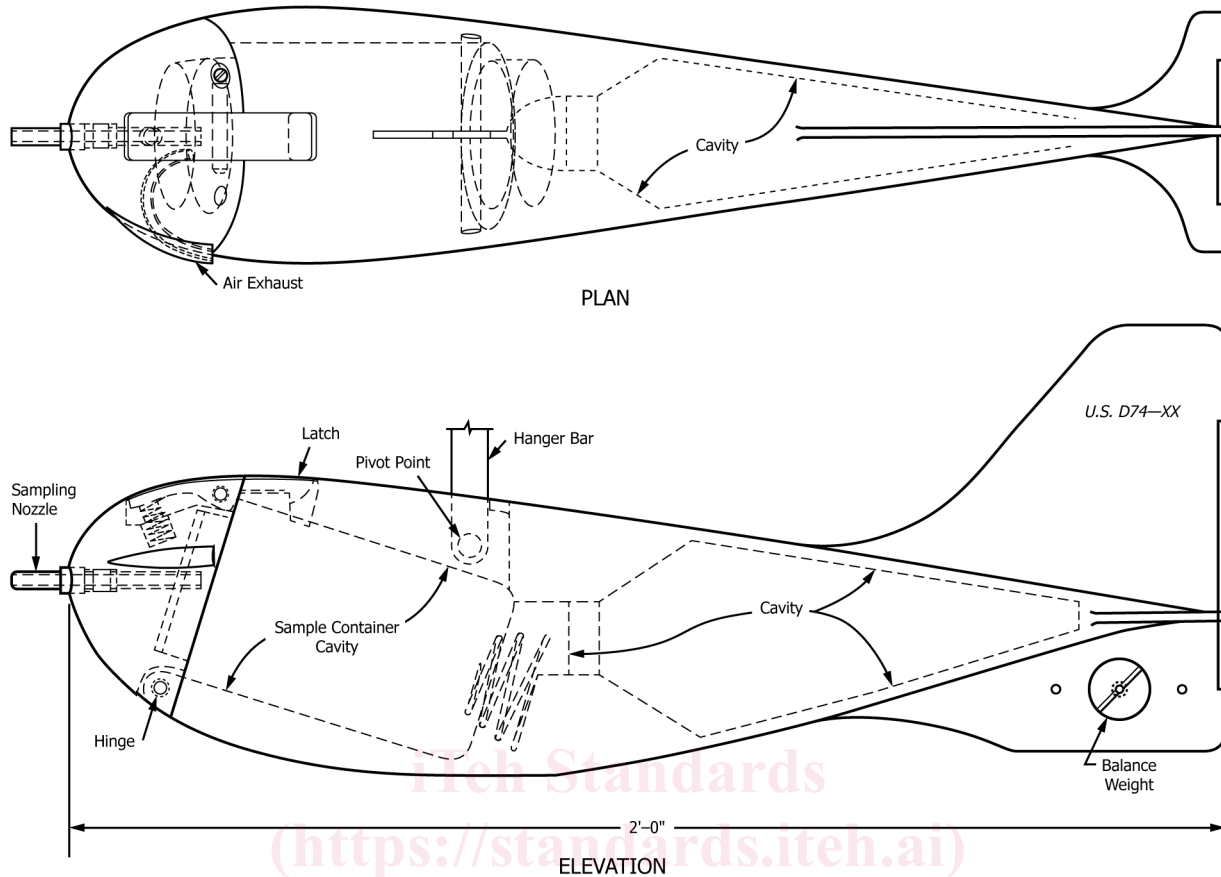

FIG. 3 (7) US D-74 Suspended Sediment Sampler

integration starting at the water surface, the depth limitations given in footnote B of Table 1(6) specify the length of the allowable two-way vertical sampling path for any single-sample container; segments of an allowable path length can be sampled throughout all or any part of the maximum allowable depth by using multiple containers and opening and closing the intake-exhaust valve appropriately. In addition to a suspension and speed indicating system, the samplers also require a source of electrical power.

10. Bedload Samplers

10.1 Both in Europe and the United States many different kinds of bedload monitoring apparatus (9) have been developed to measure the transport of a wide variety of bed-material particles that occur in nature. In general, each kind of apparatus was designed to monitor a particular range of bedload sizes and transport rates. Two broad classifications exist, direct-measuring apparatus and indirect-measuring apparatus. Direct-measuring apparatus collect and accumulate bedload particles for a given period of time. Indirect-measuring apparatus monitor some property of the bedload or some phenomena that occurs as a result of bedload movement. In addition, bedload discharge can be determined from measurements of the rate of (1) migration of bedforms, (2) movement of tracer particles, (3) deposition or erosion in a given area, and (4) change with distance in the concentration of some nonconservative property associated with the bedload particles. This nonconservative property, such as radioactivity, must have a known time rate of decay.

10.1.1 No portable direct-measuring apparatus nor indirect technique is generally accepted at this time as being entirely suitable for determining bedload discharge.

10.2 *Direct Measuring Apparatus*—Direct-measuring apparatus can be classified into four general categories; box or basket samplers, pan or tray samplers, pressure-difference samplers, and slot or pit samplers.

10.2.1 *Box or Basket Samplers*—Enclosures are open at the upstream end and possibly at the top, and have either solid sides, mesh sides, or a combination of both. Particles are retained within the sampler either by being screened from the flow or by settling in regions of reduced flow velocities within the sampler.

10.2.2 *Pan or Tray Samplers*—These samplers collect particles that drop into one or more sections or slots after the particles have been transported up an entrance ramp.

10.2.3 *Pressure-Difference Samplers*—Essentially box or basket samplers that have entrances or other features that create a pressure drop that overcomes the flow resistance within the sampler and thereby keeps flow velocities at the entrance about the same as the stream velocity.

10.2.4 *Slot or Pit Samplers*—These samplers consist of collection chambers that accumulate particles as they drop over the forward edge of a chamber that is buried in the stream bed.

10.3 *Indirect-Measuring Apparatus*—Most indirect-measuring apparatus are acoustical devices that measure (1) the magnitude and frequency of particle-sampler or particle-particle collisions or (2) the attenuation of energy. Apparatus of this type ordinarily give only qualitative information and their outputs must be correlated with known discharges to provide quantitative results. Acoustic devices are seldom used in routine data collection programs.

11. Total-Sediment Discharge Samplers

11.1 Because the total sediment discharge is composed of suspended-sediment particles, which moves along within the body of the flow essentially at stream velocity, and bedload particles, which moves in an interrupted fashion essentially in continuous contact with the bed, no practical sampler has been designed for sampling total-sediment discharge at regular river sections. Normally, the total sediment discharge is determined from separate measurements of the suspended sediment discharge and the bedload discharge. Conventional sampling equipment can be used to measure the total sediment discharge at certain sections termed total-load sections. At an outfall, a sill, a weir, or a section where flow turbulence is sufficient to entrain all the sediment within the flow, suspended-sediment sampling equipment and techniques can be used to determine the discharge of particles finer than 2 mm. For particles coarser than 2 mm, use equipment that is capable of collecting and retaining coarse particles, and that is based on the isokinetic principles of suspended-sediment sampling. Such equipment includes slot samplers. Economic considerations usually preclude the construction of artificial total-load sections except on small streams. The ASCE Manual (10) illustrates a large but expensive turbulence flume.

11.2 If sampling can be conducted at a free outfall, slot samplers can be installed. By means of a slotted conduit positioned in the outfall, the slot sampler diverts a fraction of the water-sediment mixture into a suitable container. Slot samplers have been used extensively in erosion research and in laboratory flumes but standard designs have not been perfected for sampling sediment or industrial waste water in open channels or streams. Slot samplers are normally used in conjunction with a flume, weir, or other flow measuring devices.

11.3 The slot width must be adequate to permit free passage of the largest sediment particle; the conduit must be streamlined to minimize disturbance to the flow. Sides of the slot may be formed from rigid-metal sheets that are supported so that the slot opening faces the flow. The slot edges should be knife sharp and true to line. A tube or flexible pipe connected to the bottom of the slot carries the sample to a suitable storage container. The sampler is mounted on the downstream end of a flow measuring device with a free overfall. The height of the sampler slot must exceed the depth of flow. Some slot samplers will not function properly if the flow transports debris capable of clogging the slot. The slot may be located at a fixed point in the flow or it may be propelled across the flow. Accordingly, slot samplers may be divided into two broad categories, stationary or transversing.

11.4 *Stationary Slot Samplers*—Stationary slot samplers are simple to build and operate. They require no external source of power. To enhance self-clearing of debris, incline the slot at a slight downward angle. Fig. 4(11) illustrates several types that have been tested. Samples are extracted along one fixed line so they are less representative than those collected with a traversing slot.

11.5 *Traversing Slots*—Traversing slots collect a sample representative of the entire cross section. The vertical slot sampler requires electric power, and is relatively insensitive to approach conditions. In situations where only infrequent clogging is anticipated, satisfactory performance may be obtained by using brushes or other equipment to periodically clean the slot.

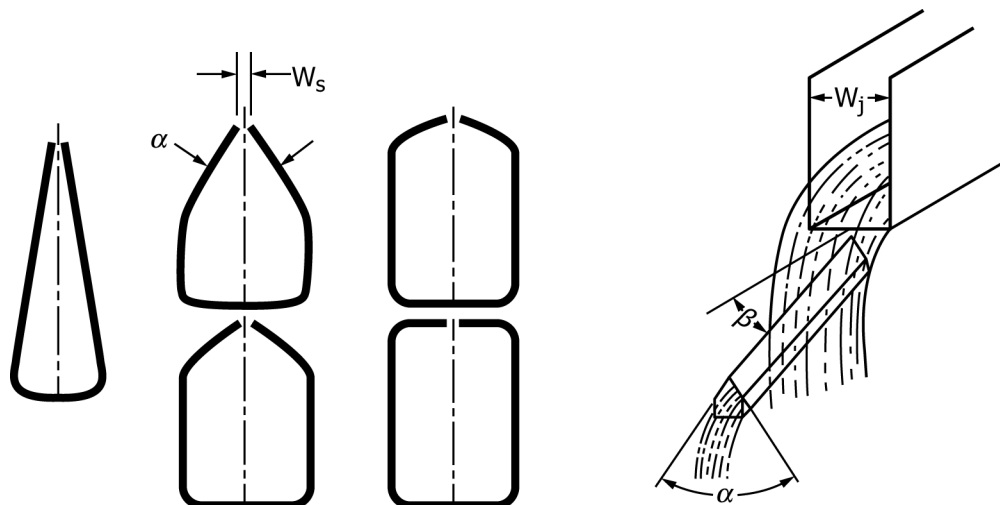

FIG. 4 (11) Cross Sections and Installation of Slot-Type Sampler

brushes mounted so that the slot is brushed before each pass through the flow nappe will usually assure satisfactory performance. Fig. 5(12) illustrates one type which has been tested.

11.6 *Rotating (Coshocton-Type) Sampler*—The rotating (Coshocton-type) sampler, (13) which is in the traversing category, consists of an elevated slot affixed to a revolving water wheel that is mounted on the downstream end of a small H-flume. Discharge from the flume falls on the water wheel and causes it to rotate. With each revolution the sampling slot cuts across the flow jet and extracts a sample. The sample falls into a collecting pan beneath the wheel and is routed through a closed conduit to a storage tank. A typical Coshocton-type sampler is pictured in Fig. 6(13) and Fig. 7(13). Sampler size, maximum discharge rate, sampling ratio, and other pertinent data are given in Table 2(14).

11.6.1 The Coshocton sampler requires no external power source, however it is sensitive to upstream approach conditions. Rotation of the wheel may become erratic at stream discharges that exceed 80 % of the flume capacity.

12. Hazards

12.1 *Personal Clothing, Equipment, and Training*—Operators should wear protective footwear and protective headgear, safety glasses, and leather gloves in addition to high-visibility clothing that is warm enough to prevent hypothermia and a Coast Guard approved personal flotation device. Where drowning is a hazard, perform sampling by teams that are wearing Coast Guard-approved personal-flotation devices and that are proficient in both swimming and first aid.

12.2 *Electrical Hazard*—(Warning—Equipment powered from low-voltage batteries is safer than equipment powered from 120-V, a-c distribution circuits. Regardless of the power source, ground the frames of hoists and other equipment to nearby metal objects such as bridge railings, bridge decks, or boat hulls. Use ground-fault detectors where applicable. During electrical storms, operators should retreat to low ground or take cover in a building or metal-topped vehicle.)

12.3 *Vehicles*—Equip vehicles that must be parked on road shoulders with warning lights and flares in compliance with local regulations. Isolate the cargo area from the driver-passenger area; lash the cargo to prevent tipping or sliding.

12.4 *Sampling Wadable or Ice-Covered Streams*—At crossings that appear marginal from safety aspects, test the surface with a rod or ice chisel, and wear a safety line anchored to a firm object on the shore. Wear a Coast Guard approved personal flotation device.

12.5 *Sampling from Overhead Cableways and Bridges*—Inspect supports and safety railings regularly for loose, worn, or weak components. At sites where trees or other heavy debris may snag a submerged sampler, the operator should be prepared to sever the suspension cable if the sample cannot be retrieved. Wear a Coast Guard approved personal flotation device.

12.6 *Reports and Medical Treatment*—Report all accidents and potentially dangerous situations promptly to the local safety officer. To save valuable time when an accident occurs, procedures for obtaining professional emergency treatment should be clearly understood by all operators.

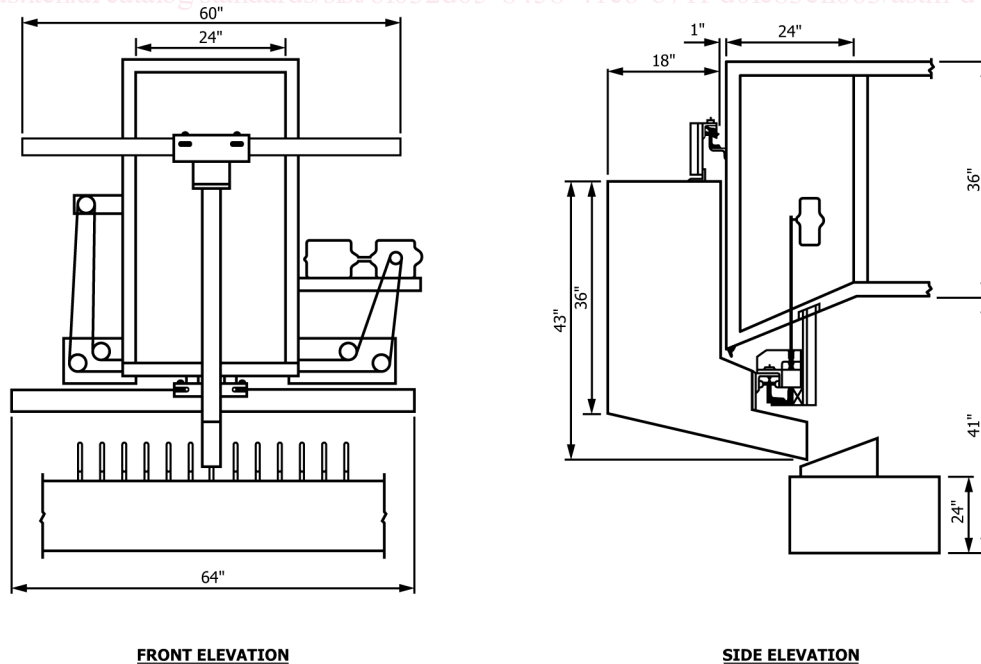

NOTE 1—1 in. = 25.4 mm. 1 ft = 0.3 m.

FIG. 5 (12) Space Required for the Traversing-Slot Sampler Mounted on a 2-ft Parshall Flume

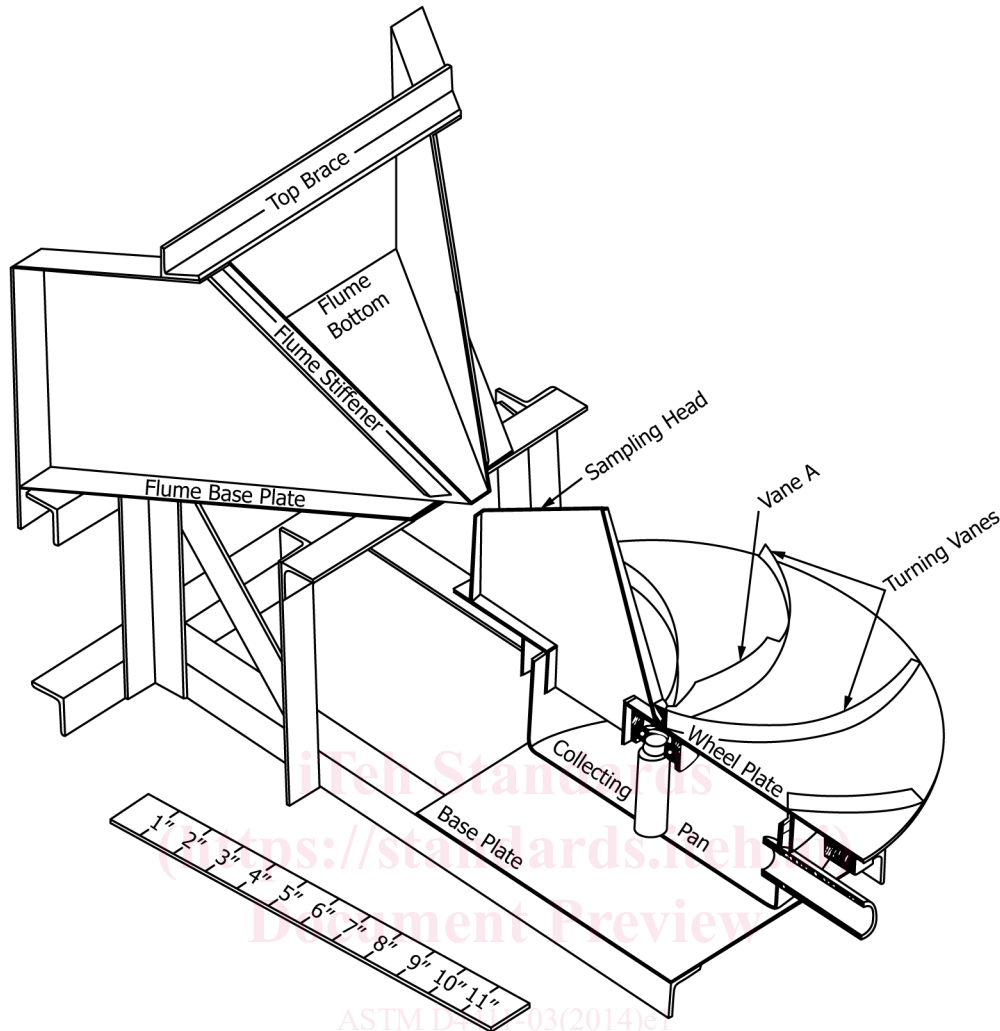

FIG. 6 (13) The N-1 Coshocton-Type Runoff Sampler

13. Sampling Techniques

13.1 Techniques for Sampling Suspended Sediment:

13.1.1 Because of spatial variations in suspended sediment concentrations and in flow velocity, the discharge of suspended sediment through an area at any given instant is defined by Eq 1(15) as follows:

$$G_{ss} = \int_A C U dA \quad (1)$$

where:

G_{ss} = “instantaneous” suspended sediment discharge through a section of area A,

U = velocity of sediment particles through an elemental area dA,

C = suspended sediment concentration in the elemental spatial volume $U t' dA$,

for which:

t' = unit of the time used to express U .

In the practical application of Eq 1, U is considered to equal the flow velocity and C is considered to be constant during any given sampling period.

13.1.2 Three different techniques are commonly used to evaluate Eq 1; point integration, depth integration, and area integration. In point integration, samplers and sampling procedures are designed to yield spatial concentrations at a series of points throughout an area. These concentrations together with flow velocities from individual points are used to define concentration and velocity gradients, which, in turn are integrated according to Eq 1 to give the instantaneous suspended-sediment discharge through the area.