



Designation: D2162 – 14

# Standard Practice for Basic Calibration of Master Viscometers and Viscosity Oil Standards<sup>1</sup>

This standard is issued under the fixed designation D2162; the number immediately following the designation indicates the year of original adoption or, in the case of revision, the year of last revision. A number in parentheses indicates the year of last reapproval. A superscript epsilon ( $\epsilon$ ) indicates an editorial change since the last revision or reapproval.

## 1. Scope\*

1.1 This practice covers the calibration of master viscometers and viscosity oil standards, both of which may be used to calibrate routine viscometers as described in Test Method D445 and Specifications D446 over the temperature range from 15 °C to 100 °C.

1.2 The values stated in SI units are to be regarded as standard. No other units of measurement are included in this standard.

1.2.1 The SI-based units for calibration constants and kinematic viscosities are  $\text{mm}^2/\text{s}^2$  and  $\text{mm}^2/\text{s}$ , respectively.

1.3 *This standard does not purport to address all of the safety concerns, if any, associated with its use. It is the responsibility of the user of this standard to establish appropriate safety and health practices and determine the applicability of regulatory limitations prior to use.* For specific warning statements, see Section 7.

## 2. Referenced Documents

2.1 *ASTM Standards:*<sup>2</sup>

D445 Test Method for Kinematic Viscosity of Transparent and Opaque Liquids (and Calculation of Dynamic Viscosity)

D446 Specifications and Operating Instructions for Glass Capillary Kinematic Viscometers

D1193 Specification for Reagent Water

D1250 Guide for Use of the Petroleum Measurement Tables

D1480 Test Method for Density and Relative Density (Specific Gravity) of Viscous Materials by Bingham Pycnometer

D1590 Test Method for Surface Tension of Water

E1 Specification for ASTM Liquid-in-Glass Thermometers

E563 Practice for Preparation and Use of an Ice-Point Bath as a Reference Temperature

E644 Test Methods for Testing Industrial Resistance Thermometers

E1137 Specification for Industrial Platinum Resistance Thermometers

E1750 Guide for Use of Water Triple Point Cells

E2593 Guide for Accuracy Verification of Industrial Platinum Resistance Thermometers

E2877 Guide for Digital Contact Thermometers

2.2 *ISO Standard:*<sup>3</sup>

ISO 3666 Viscosity of Water

## 3. Terminology

3.1 *Definitions:*

3.1.1 *digital contact thermometer (DCT)*, *n*—an electronic device consisting of temperature measuring sensor in contact with the material that provides an output to a digital display of the measured value.

3.1.1.1 *Discussion*—This device consists of a temperature sensor connected to a measuring instrument; this instrument measures the temperature-dependent quantity of the sensor, computes the temperature from the measured quantity, and provides a digital output. This digital output goes to a digital display and/or recording device that may be internal or external to the device. These devices are sometimes referred to as a “digital thermometer”.

NOTE 1—Portable electronic thermometers (PET) is an acronym sometimes used to refer to a subset of the devices covered by this definition.

3.2 *Definitions of Terms Specific to This Standard:*

3.2.1 *basic calibration*, *n*—calibration based on the primary standard, water.

3.2.1.1 *Discussion*—Pure water has a kinematic viscosity of 1.0034  $\text{mm}^2/\text{s}$  at 20 °C. See ISO 3666.

3.2.2 *master viscometer*, *n*—glass capillary viscometer with a liquid driving head of at least 400 mm.

3.2.2.1 *Discussion*—It is specially designed to minimize errors due to surface tension, kinetic energy, and capillary end effects.

<sup>3</sup> Available from American National Standards Institute (ANSI), 25 W. 43rd St., 4th Floor, New York, NY 10036.

<sup>1</sup> This practice is under the jurisdiction of ASTM Committee D02 on Petroleum Products, Liquid Fuels, and Lubricants and is the direct responsibility of Subcommittee D02.07 on Flow Properties.

Current edition approved June 1, 2014. Published July 2014. Originally approved in 1963. Last previous edition approved in 2013 as D2162 – 13. DOI: 10.1520/D2162-14.

<sup>2</sup> For referenced ASTM standards, visit the ASTM website, www.astm.org, or contact ASTM Customer Service at service@astm.org. For *Annual Book of ASTM Standards* volume information, refer to the standard's Document Summary page on the ASTM website.

- A = 7 - 8 O.D.**
- B = 3 mL - 3.3 mL + Volume F**
- C & E - Etched Lines**
- D = 3 mL - 3.3 mL**
- F = Working Capillary**
- G = 8 - 9 O.D.**
- J = 12 - 13 O.D.**
- N = 30 ± 1 I.D.**
- Dimensions are in mm**

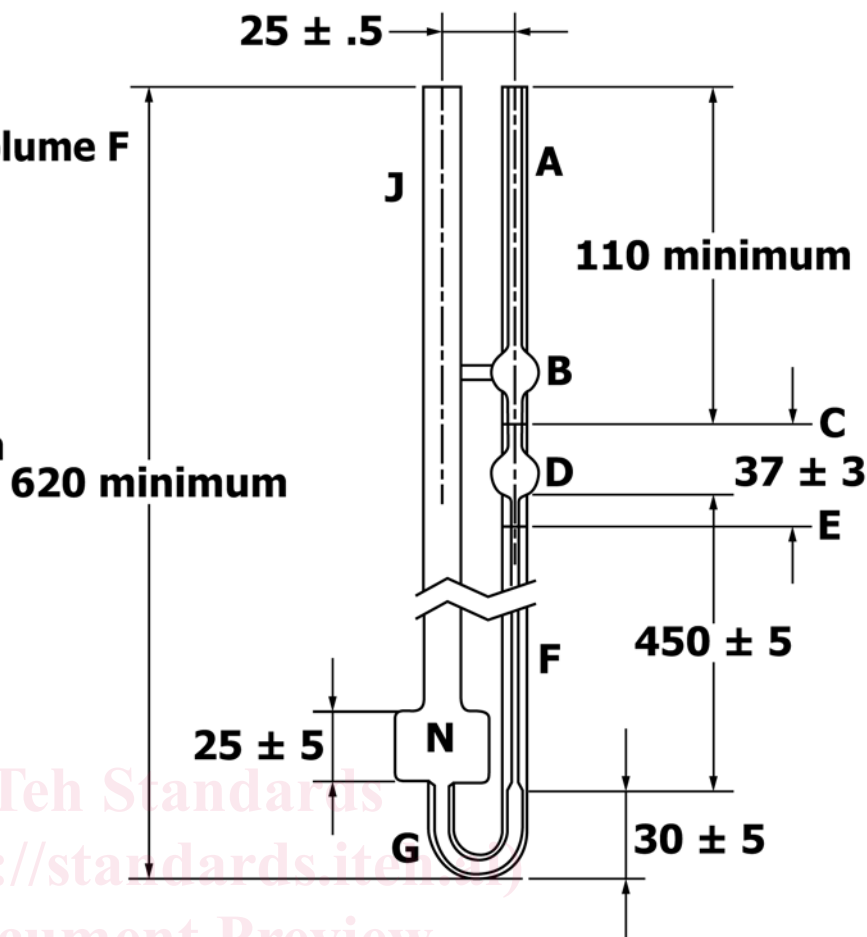

FIG. 1 Cannon Master Viscometer

3.2.3 *viscosity oil standard, n*—stable Newtonian liquid, the kinematic viscosity of which has been related to the kinematic viscosity of water through the step-up procedure described in this practice.

#### 4. Summary of Practice

4.1 Two or more master viscometers, having calibration constants in the 0.001 mm<sup>2</sup>/s<sup>2</sup> to 0.003 mm<sup>2</sup>/s<sup>2</sup> range, are calibrated with water at 20 °C. The kinematic viscosities of two or more oil standards are measured at 40 °C in these two master viscometers. Corrections are made for buoyancy and, where necessary, for temperature and surface tension.

4.2 A third master viscometer, with a calibration constant of 0.003 mm<sup>2</sup>/s<sup>2</sup> to 0.009 mm<sup>2</sup>/s<sup>2</sup>, is then calibrated at 40 °C with the two standard oils and its calibration factor calculated at standard conditions for water at 20 °C. In like manner additional viscosity oil standards and additional master viscometers are calibrated at 40 °C using the average results from at least two master viscometers or two oil standards. Steps between successive calibration constants or viscosities increase by a factor of three or less until the desired viscosity range is covered.

4.3 Oils are calibrated at other temperatures using the average result from at least two master viscometers.

#### 5. Significance and Use

5.1 Because there are surface tension or kinematic viscosity differences, or both, between the primary standard (7.4) and kinematic viscosity standards (7.5), special procedures using master viscometers are required to “step-up” from the kinematic viscosity of the primary standard to the kinematic viscosities of oil standards.

5.2 Using master viscometers calibrated according to this practice, an operator can calibrate kinematic viscometers in accordance with Specifications D446.

5.3 Using viscosity oil standards established in this practice, an operator can calibrate kinematic viscometers in accordance with Specifications D446.

#### 6. Apparatus

6.1 *Master Viscometers: Cannon*<sup>4</sup> or Ubbelohde<sup>5</sup> Type—Acceptable viscometers are shown in Fig. 1 and Fig. 2. Two masters are required with calibration constants in the

<sup>4</sup> Cannon, M. R., “Viscosity Measurement, Master Viscometers,” *Industrial and Engineering Chemistry*. Analytical Edition, Vol 16, 1944, p. 708.

<sup>5</sup> Ubbelohde, L., “The Suspended Lever Viscometer,” *Journal Institute Petroleum Technologists* (London), Vol 22, 1936, p. 37.

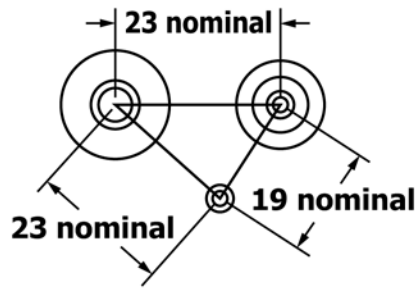

- A = 6 - 7 O.D. & 1 - 1.25 Wall**
  - B = 12 O.D.**
  - C & E - Etched Lines**
  - D = 5.1 mL ± 0.1 mL & ~ 23 O.D.**
  - F = Working Capillary**
  - G = 17 - 19 O.D.**
  - H = 9 - 10 O.D. & 1.25 - 2 Wall**
  - J = 23 - 25 O.D.**
  - M = 12 - 13 O.D. & 1 - 1.25 Wall**
  - N = 6 - 7 O.D. & 1 - 1.25 Wall**
- Dimensions are in mm**

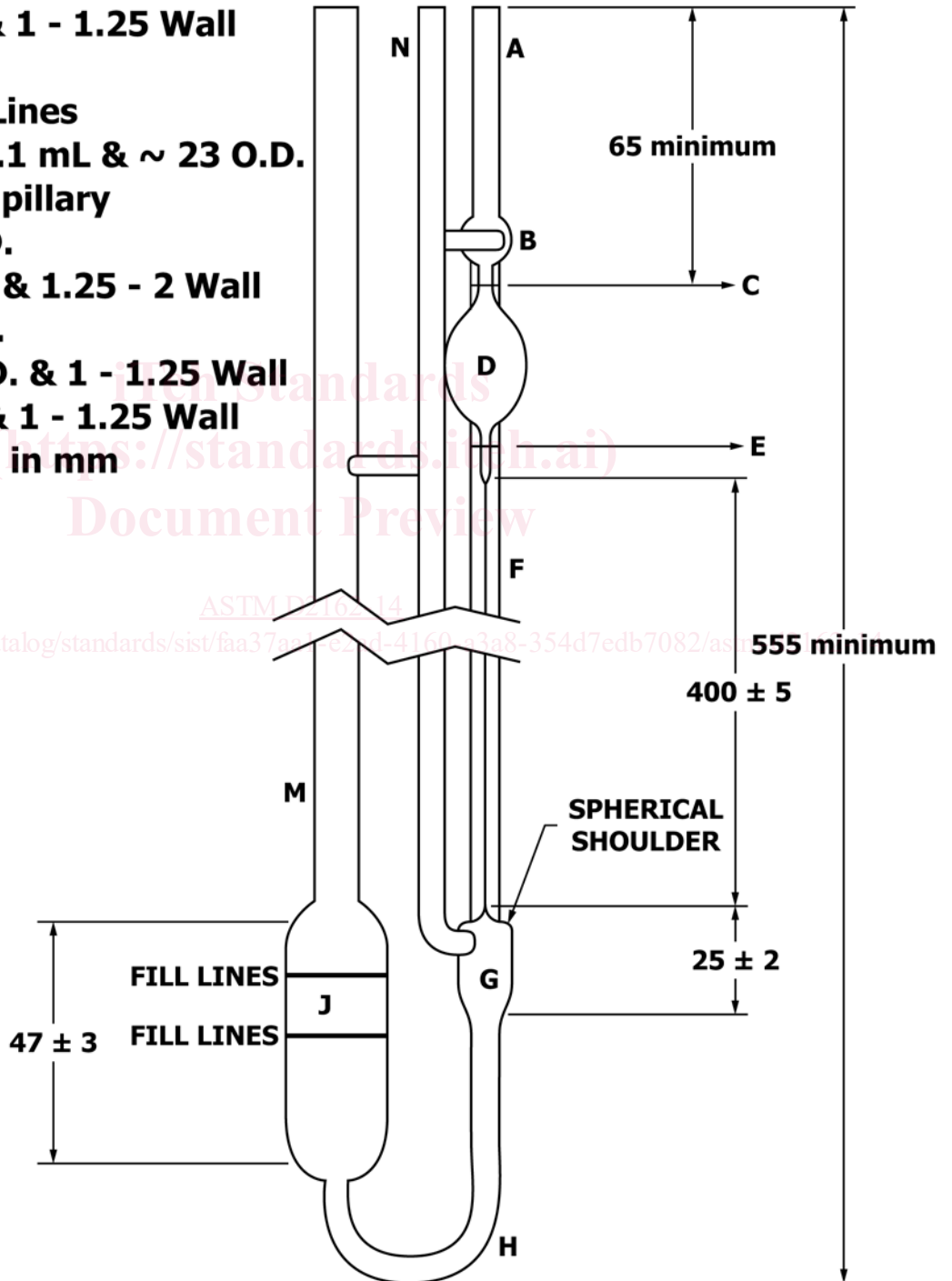

FIG. 2 Ubbelohde Master Viscometer

0.001 mm<sup>2</sup>/s<sup>2</sup> to 0.003 mm<sup>2</sup>/s<sup>2</sup> range. Additional masters have factors increasing in three-fold steps.

6.2 *Temperature Measuring Devices*—Use either a digital contact thermometer (DCT) or a liquid-in-glass thermometer meeting the requirements in 6.2.1 or 6.2.1.1 respectively:

6.2.1 *Digital Contact Thermometer*—A device conforming to Guide E2877 Class A and meeting or exceeding the following additional requirements:

(1) The only acceptable sensors are resistance temperature devices (RTD) or high precision thermistors. However a standard platinum resistance thermometer (SPRT) is preferable.

(2) Meeting Class A requirements of Guide E2877 preferably with a minimum display resolution of 0.001 °C.

(3) A combined (display and probe) accuracy of ±7 mK (0.007 °C) at a 95 % confidence level over intended range of use.

(4) A response time of less than 25 s as defined in Specification E1137.

(5) Linearity of less than 7 mK (0.007 °C) over the range of temperatures to be measured.

(6) Both the temperature sensor and measurement bridge components of the DCT shall have a report of temperature calibration from a calibration laboratory with a demonstrated competency in temperature calibration traceable to a national calibration or metrology standards body.

(7) The calibration report shall include data for the series of test points which are appropriate for the range of intended use.

(8) If the DCT display unit (measuring instrument such as a bridge) is calibrated separate from the probe, it should be calibrated annually.

6.2.1.1 The DCT probe is to be immersed by more than its minimum immersion depth in a constant temperature bath so that the center of the probe's sensing region is at the same level as the lower half of the working capillary provided the probes minimum immersion depth is met. The end of the probe's sheath shall not extend past the bottom of the viscometer's lower reservoir.

NOTE 2—With respect to DCT probe immersion depth, a procedure is available in Test Methods E644, Section 7, for determining the minimum depth. With respect to an ice bath, Practice E563 provides guidance on the preparation of an ice bath however variance from the specific steps is permitted provided preparation is consistent as it is being used to track change in calibration.

6.2.1.2 Verify the calibration at least annually. The probe shall be recalibrated when the check value differs by more than 0.01 °C from the last probe calibration. Verification can be accomplished with the use of a water triple point cell, an ice bath or other suitable constant temperature device which has a known temperature value of suitable precision. See Practice E563, Guide E1750, and Guide E2593 for more information regarding checking calibrations.

6.2.2 *Liquid-in-Glass Thermometer*—Kinematic viscosity thermometers having a range from 18.5 °C to 21.5 °C, or 38.5 °C to 41.5 °C, and conforming to the requirements for Thermometers 44C and 120C, as prescribed in Specification E1, and calibrated to ±5 mK (0.005 °C). The thermometer shall have a report of temperature calibration from a calibration

laboratory with a demonstrated competency in temperature calibration traceable to a national calibration or metrology standards body.

6.2.2.1 *Calibration Check*—Verify the thermometer at least annually against a reference thermometer in a constant temperature bath or an ice bath. The thermometer is to be inserted to its immersion depth. If using an ice bath, the ice point reading is to be taken within 60 min after the thermometer has been at test temperature for at least 3 min. If the corrected temperature reading deviates more than the calibration tolerance from the reference thermometer or the ice point then repeat this calibration check. If the thermometer deviates from the reference value on two successive checks then a full thermometer recalibration is needed.

6.2.2.2 *Recalibration*—A complete recalibration of the liquid-in-glass thermometer, while permitted, is not necessary in order to meet the accuracy ascribed to liquid-in-glass thermometer's design until the thermometers corrected measured temperature deviates from the reference thermometer or ice point by one scale division, or until five years has elapsed since the last full calibration.

6.3 *Bath*—A thermostated bath containing water or other transparent liquid deep enough to immerse the master viscometers so that the upper fiducial mark is at least 50 mm below the surface. The efficiency of stirring and the balance between heat loss and input must be such that the temperature of the water does not vary by more than ±0.01 °C over the length of the viscometer or from one viscometer position to another. The working section of the bath should be shielded from direct radiation from heaters and lights. A standard platinum resistance thermometer, approximately 450 mm in length, may be used to ensure that the variation in temperature does not exceed ±0.01 °C. Firm supports should be provided to hold the master viscometer in a rigid and reproducible position within 0° 15 min of vertical.

6.4 *Timer*—A spring-wound, electric, or digital timer capable of measuring time intervals of 300 s to 10 000 s with an accuracy of ±0.03 %. The stop watch, fully but not tightly wound, must be used and tested in the same position. For example, if used at 45° inclination, it should have been tested previously in that position. Electric, not electronic, timers must be operated on circuits, the frequencies of which are controlled. Commercial power sources, the frequencies of which are intermittently and not continuously controlled, are not satisfactory. Both mechanical and electric timers can be sensitive to abnormally low ambient temperature and should not be used when cold.

NOTE 3—Time signals as broadcast by the National Institute of Standards and Technology are a convenient and primary standard reference for calibrating timing devices. The following can be used:

WWV	Fort Collins, CO	(2.5, 5, 10, 15, 20) MHz
WWVH	Kauai, HI	(2.5, 5, 10, 15) MHz
CHU	Ottawa, Canada	(3.33, 7.335, 14.67) MHz

Radio broadcast of voice and audio on a telephone line at phone number: 303-499-7111. Additional time services are available from the National Institute of Standards and Technology.

6.4.1 The timer shall be calibrated at least every 12 months.

NOTE 4—A laboratory's measurement uncertainty is dependent on the