



Designation: ~~D1838~~—~~12a~~ **D1838 – 14**

Standard Test Method for Copper Strip Corrosion by Liquefied Petroleum (LP) Gases¹

This standard is issued under the fixed designation D1838; the number immediately following the designation indicates the year of original adoption or, in the case of revision, the year of last revision. A number in parentheses indicates the year of last reapproval. A superscript epsilon (ϵ) indicates an editorial change since the last revision or reapproval.

1. Scope*

1.1 This test method covers the detection of the presence of components in liquefied petroleum gases which can be corrosive to copper.

NOTE 1—For an equivalent copper strip test applicable to less volatile petroleum products, see Test Method **D130**.

1.2 The values stated in SI units are to be regarded as standard. The values given in parentheses are for information only.

1.3 *This standard does not purport to address all of the safety concerns, if any, associated with its use. It is the responsibility of the user of this standard to establish appropriate safety and health practices and determine the applicability of regulatory limitations prior to use.* For specific warning statements, see **7.1**, **10.3.1**, and **Annex A1**.

2. Referenced Documents

2.1 *ASTM Standards:*²

D130 Test Method for Corrosiveness to Copper from Petroleum Products by Copper Strip Test

D1265 Practice for Sampling Liquefied Petroleum (LP) Gases, Manual Method

D3700 Practice for Obtaining LPG Samples Using a Floating Piston Cylinder

2.2 *ASTM Adjuncts:*

ADJD0130, ASTM Copper Strip Corrosion Standard for Petroleum³

3. Terminology

3.1 *Abbreviations:*

3.1.1 *CAMI*—Coated Abrasives Manufacturers Institute

3.1.2 *FEPA*—Federation of European Producers Association

4. Summary of Test Method

4.1 A polished copper strip is immersed in approximately 100 mL of the sample and exposed at a temperature of 37.8°C (100°F) for 1 h in a cylinder of suitable working pressure. At the end of this period, the copper strip is removed and rated as one of the four classifications of the ASTM Copper Strip Corrosion Standard (ADJD0130).

5. Significance and Use

5.1 Copper corrosion limits provide assurance that difficulties will not be experienced in deterioration of the copper and copper-alloy fittings and connections that are commonly used in many types of utilization, storage, and transportation equipment.

6. Apparatus

6.1 *Corrosion Test Cylinder*, constructed of stainless steel with an O-ring removable top closure according to the dimensions given in **Fig. 1**. Provide a flexible inert hose, such as one composed of aluminum or stainless steel, which permits inverting the

¹ This test method is under the jurisdiction of ASTM Committee **D02** on Petroleum Products—Products, Liquid Fuels, and Lubricants and is the direct responsibility of Subcommittee **D02.H0** on Liquefied Petroleum Gas.

Current edition approved Dec. 1, 2012; June 1, 2014. Published March 2013/July 2014. Originally approved in 1961. Last previous edition approved in 2012 as **D1838D1838 – 12a, – 12**. DOI: 10.1520/D1838-12A.10.1520/D1838-14.

² For referenced ASTM standards, visit the ASTM website, www.astm.org, or contact ASTM Customer Service at service@astm.org. For *Annual Book of ASTM Standards* volume information, refer to the standard's Document Summary page on the ASTM website.

³ Available from ASTM International Headquarters. Order Adjunct No. **ADJD0130**.

*A Summary of Changes section appears at the end of this standard

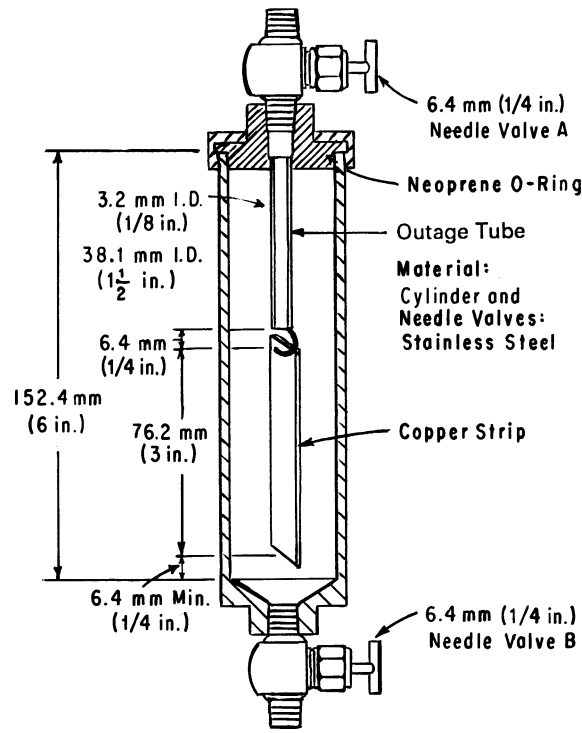

in.	mm	Metric Equivalents	in.	mm
1/8	3.2		3	76
1/4	6.4		6	152
1 1/2	38.1			

FIG. 1 Copper Strip Corrosion Test Cylinder

test cylinder as required in the procedure (see [Note 26.1.1](#)). The whole assembly, including the corrosion test cylinder, shall be constructed to withstand a minimum hydrostatic test pressure of 6900 kPa (1000 psig). No leak shall be discernible when tested at 3450 kPa (500 psig) with gas.

NOTE 2—Swivel connections with an adapter to fit a 6.4 mm (1/4 in.) pipe may be used.

6.1.1 Swivel connections with an adapter to fit a 6.4 mm (1/4 in.) pipe may be used.

6.1.2 The assembly shall be tested for compliance with the minimum pressure rating of 6900 kPa (1000 psig) by hydrostatic testing, or alternative testing protocol acceptable to the local authority having jurisdiction, prior to first use. Additional testing can be required by the local authority having jurisdiction.

6.1.3 The assembly shall be verified for gas tightness by leak testing at a minimum of 3450 kPa (500 psig) with inert gas prior to first use, whenever pressure-containing components of the assembly are replaced, or otherwise on an annual basis.

6.1.4 Note the presence and length (about 60 mm) of the outage tube shown in [Fig. 1](#), to provide adequate ullage for safety. A safety pressure relief device may also be incorporated into the design of the corrosion test cylinder, if desired. If a pressure relief device is incorporated, ensure that the materials of its construction will not affect the test results.

6.2 *Water Bath*, capable of being maintained at $37.837.8\text{ }^{\circ}\text{C} \pm 0.5^{\circ}\text{C}$ ($100.5\text{ }^{\circ}\text{C} (100\text{ }^{\circ}\text{F} \pm 1^{\circ}\text{F})$). Incorporate suitable supports to hold the test cylinder in an upright position. Make the bath deep enough so that the entire cylinder and valves will be covered during the test.

6.3 *Temperature Sensing Device (TSD)*—Capable of monitoring the desired test temperature in the bath to within an accuracy of $\pm 0.5^{\circ}\text{C} (1^{\circ}\text{F}) \pm 0.5\text{ }^{\circ}\text{C} (1\text{ }^{\circ}\text{F})$ or better.

6.4 *Strip Polishing Vise*, to hold the copper strip firmly without marring the edges. For convenient vises see Test Method [D130](#).

7. Materials

7.1 *Wash Solvent*—Any volatile, less than 5 mg/kg sulfur, hydrocarbon solvent may be used provided that it shows no tarnish at all when tested for 3 h at $50^{\circ}\text{C} (122^{\circ}\text{F})$, $50\text{ }^{\circ}\text{C} (122\text{ }^{\circ}\text{F})$. 2,2,4-trimethylpentane (isooctane) of minimum 99.75 % purity is the referee solvent and should be used in case of dispute. (**Warning**—Extremely flammable, see [Annex A1](#).)

7.2 Copper Strip, Strip Specification—~~approximately~~ Use strips that are $12.5 \text{ mm} \pm 2 \text{ mm}$ ($\frac{1}{2}$ in.) wide, ~~$\pm 1.5 \text{ mm}$ to 3.0 mm~~ 3.2 mm ($\frac{1}{16}$ to $\frac{1}{8}$ in.) thick, ~~cut approximately 75 mm~~ and cut $75 \text{ mm} \pm 5 \text{ mm}$ (3 in.) long from smooth-surfaced, hard-temper, cold-finished copper of ~~99.9 + 99.9+~~ % purity; electrical bus bar stock is generally suitable. Drill a 3.2 mm ($\frac{1}{8}$ in.) hole approximately 3.2 mm ($\frac{1}{8}$ in.) from one end in the center of the strip. The strips may be used repeatedly but ~~should be discarded if surfaces become deformed~~ shall be discarded when the strip's surface shows pitting or deep scratches that cannot be removed by the specified polishing procedure, or when the surface becomes deformed, or the dimensions for the copper strip fall outside the specified limits.

7.3 Surface Preparation/Polishing Materials—00 grade or finer steel wool; silicon carbide grit paper or cloth of varying degrees of fineness including $65\text{-}\mu\text{m}$ grade (220-grit CAMI-grade or P220 FEPA-grade); also a supply of $105\text{-}\mu\text{m}$ (120-grit to 150-grit CAMI-grade or P120 to P150 FEPA-grade) size silicon carbide grain or powder and absorbent cotton. A commercial grade is suitable, but pharmaceutical grade cotton wool is most commonly available and is acceptable.

7.4 ASTM Copper Strip Corrosion Standard (ADJD0130), Plaques are available.³ Their care and inspection for stability are described in detail in Test Method **D130**.

8. Preparation of Strips

8.1 Surface Preparation—Remove all surface blemishes from all six sides of the strip obtained from a previous analysis. One way to accomplish this is to use 00 grade or finer steel wool or silicon carbide paper or cloth of such degrees of fineness as are needed to accomplish the desired results efficiently. Finish with $65\text{-}\mu\text{m}$ grade (220-grit CAMI-grade or P220 FEPA-grade) silicon carbide paper or cloth, removing all marks that could have been made by other grades of paper used previously. Ensure the prepared copper strip is protected from oxidation prior to final preparation, such as by immersing the strip in wash solvent from which it can be withdrawn immediately for finish preparation (polishing) or in which it can be stored for future use.

8.1.1 Only final preparation (8.2) is necessary for commercially purchased pre-polished strips.

8.1.2 As a practical manual procedure for surface preparation, a sheet of silicon carbide paper may be placed on a flat surface and then moisten the paper with wash solvent before rubbing the strip against the silicon carbide paper or cloth with a circular motion. Protect the strip from contact with the fingers, such as by using ashless filter paper. Alternatively, the surface of the strip may be prepared by use of motor-driven machines using appropriate grades of dry paper or cloth.

8.2 Final Preparation—For strips prepared in 8.1 or new strips being used for the first time, remove a strip from its protected location, such as by removing it from the wash solvent. Polish first the ends and then the sides with the ~~$105\text{-}\mu\text{m}$~~ $105\text{-}\mu\text{m}$ (120-grit to 150-grit CAMI-grade or P120 to P150 FEPA-grade) silicon carbide grains picked up with a pad of absorbent cotton moistened with wash solvent, making sure that the surface is protected from coming in contact with the fingers, such as by using ashless filter paper. Wipe vigorously with fresh pads of absorbent cotton and subsequently handle without touching the surface of the strip with the fingers. Padded forceps (to prevent the scratching of the surface) have been found suitable to use. Secure the copper strip in a vise or suitable holder and polish the main surfaces with silicon-carbide grains on absorbent cotton. Do not polish in a circular motion. Rub in the direction of the long axis of the strip, carrying the stroke beyond the end of the strip before reversing the direction. Clean all metal dust from the strip by rubbing vigorously with clean pads of absorbent cotton until a fresh pad remains unsoiled. When the strip is clean, with minimal delay, attach to the dip tube and lower into the prepared corrosion test cylinder (see Fig. 1).

8.2.1 It is important to polish the whole surface of the strip uniformly to obtain a uniformly stained strip. If the edges show wear (surface elliptical) they will likely show more corrosion than the center. The use of a vise will facilitate uniform polishing.

8.2.2 It is important to follow the order of preparation with the correctly sized silicon carbide material as described in 8.1 and 8.2. The final preparation is with $105\text{-}\mu\text{m}$ (120-grit to 150-grit CAMI-grade or P120 to P150 FEPA-grade) silicon carbide grains. This is a larger grain size than the $65\text{-}\mu\text{m}$ grade (220-grit CAMI-grade or P220 FEPA-grade) paper used in the surface preparation stage. The reason for this use of larger silicon carbide grains in the final preparation is to produce asperities (controlled roughness) on the surface of the copper which act as sites for the initiation of corrosion reactions.

9. Sampling

9.1 Obtain a sample from a point in the LPG system that will give a representative sample of the volume being tested, such as from a dynamic flowing stream or from a well mixed container, as appropriate. Preferably, collect the sample directly into the corrosion test cylinder (6.1) after it has been prepared for testing (10.1). Pay particular attention to safety and warning notes in Practices **D1265** and **D3700**.

9.2 Alternatively, collect a sample in accordance with Practices **D1265** and **D3700**.

9.2.1 If a sample is first collected in a sampling cylinder, ensure that the interior surfaces are inert and will not react with corrosive species. Sampling cylinders with protective (inert) internal coatings or surface treatments (such as fused glass) may be used.

NOTE 2—Some internal coatings are porous and can adsorb or release contaminants that can affect test results. Also, fresh steel surfaces can react with some corrosive sulfur species and potentially remove them, which could result in a “false pass” in the copper strip corrosion test.