



Designation: ~~D2384 – 83 (Reapproved 2009)~~ **D2384 – 83 (Reapproved 2014)**

Standard Test Methods for Traces of Volatile Chlorides in Butane-Butene Mixtures¹

This standard is issued under the fixed designation D2384; the number immediately following the designation indicates the year of original adoption or, in the case of revision, the year of last revision. A number in parentheses indicates the year of last reapproval. A superscript epsilon (ϵ) indicates an editorial change since the last revision or reapproval.

1. Scope

1.1 These test methods cover the determination of the total volatile organic chlorides in concentrations from 10 to ~~100 ppm~~ **100 ppm** in butane-butene mixtures. The amperometric finish is not directly applicable in the presence of other substances that combine with silver ion or oxidize chloride ion in dilute acid solution. Bromides, sulfides, ammonia, tobacco smoke, and more than 25 μg of hydrogen peroxide in the test solution interfere in the spectrophotometric procedure.

1.2 Dissolved sodium chloride is not quantitatively determined using these test methods.

1.3 The values stated in SI units are to be regarded as standard. No other units of measurement are included in this standard.

1.4 *This standard does not purport to address all of the safety concerns, if any, associated with its use. It is the responsibility of the user of this standard to establish appropriate safety and health practices and determine the applicability of regulatory limitations prior to use.* Specific warning statements are given in Sections 5, 8, 11, 14, 19, and Annex A1.

2. Referenced Documents

2.1 *ASTM Standards:*²

[D329 Specification for Acetone](#)

[D1266 Test Method for Sulfur in Petroleum Products \(Lamp Method\)](#)

3. Summary of Test Methods

3.1 *Combination Test Methods*—Either the lamp or oxy-hydrogen test method may be used for combustion.

NOTE 1—Lamp combustion is readily applicable to multiple testing. Although an oxy-hydrogen burner does not lend itself to multiple testing, it affords much more rapid analysis for a single sample than does the lamp combustion.

3.1.1 *Lamp Combustion*—The sample is burned in an atmosphere of carbon dioxide and oxygen or in purified air; the halogen-containing combustion products are absorbed in dilute sodium carbonate solution.

3.1.2 *Oxy-Hydrogen Combustion*—The sample is burned in an oxy-hydrogen atomizer burner, and the combustion products are absorbed in a dilute solution of sodium carbonate.

3.2 *Finishes*—Either the amperometric titration or spectrophotometric finish may be used for the chloride ion determination.

3.2.1 *Amperometric Titration*—The chloride ion in aqueous solution is titrated amperometrically with standard silver nitrate solution, using a saturated calomel electrode as reference electrode. The diffusion currents are plotted against the corresponding volumes of silver nitrate solution used; the end point is taken as the intersection of the two straight-line portions of the curve.

3.2.2 *Spectrophotometric Finish*—Chloride ion in the absorber solution is determined by reaction with mercuric thiocyanate to release thiocyanate, which forms a reddish orange complex with Fe^{+++} . The intensity of the color is measured at 460 nm with a spectrophotometer or filter photometer.

4. Significance and Use

4.1 These test methods are used to determine trace amounts of volatile chlorides in butane-butene mixtures. Such information is valuable in cases where chloride is deleterious in the use of this product; also, chloride contributes to corrosion problems in processing units in instances where further processing of this material is involved.

¹ These test methods are under the jurisdiction of ASTM Committee D02 on Petroleum Products-Products, Liquid Fuels, and Lubricants and are the direct responsibility of Subcommittee D02.D0.04 on C4 Hydrocarbons.

Current edition approved July 1, 2009 May 1, 2014. Published November 2009 July 2014. Originally approved in 1965. Last previous edition approved in 2004 2009 as D2384-83(2004)-D2384-83(2009). DOI: 10.1520/D2384-83R09-10.1520/D2384-83R14.

² For referenced ASTM standards, visit the ASTM website, www.astm.org, or contact ASTM Customer Service at service@astm.org. For *Annual Book of ASTM Standards* volume information, refer to the standard's Document Summary page on the ASTM website.

5. Purity of Reagents

5.1 *Purity of Reagents*—Reagent grade chemicals shall be used in all tests. Unless otherwise indicated, it is intended that all reagents shall conform to the specifications of the Committee on Analytical Reagents of the American Chemical Society, where such specifications are available.³ Other grades may be used, provided it is first ascertained that the reagent is of sufficiently high purity to permit its use without lessening the accuracy of the determination.

5.2 References to water shall be understood to mean chloride-free distilled or deionized water.

5.3 (**Warning**)—In view of the common occurrence of chloride in reagents and laboratory air, special care must be taken during preparation and storage of reagents to avoid contamination. They should be isolated from other reagents and used solely for these methods. A blank determination must be performed each time a reagent is changed to ensure that it is not contaminated with chloride.

It is also imperative that all glassware used in this determination be cleaned thoroughly and rinsed four times with *chloride-free* distilled or deionized water. Utmost caution must be taken during the analysis to prevent contamination from chlorides.)

6. Sampling

6.1 Steam and dry a 10 to 25-mL corrosion-resistant metal sample cylinder having a 450-psi (3100 kPa) working pressure and equipped with a needle valve outlet at each end.

6.2 Pressure the prepared cylinder with dry hydrogen to ~~20 psig (137.5 kPa)~~ 20 psig (137.5 kPa gage) to afford a gas cushion preventing rupture due to liquid expansion on increase of temperature.

6.3 Obtain a liquid sample from the purged sample line, filling the upright cylinder through the bottom needle valve, keeping the top valve closed. Do not purge the sample cylinder.

LAMP COMBUSTION TEST METHOD

7. Apparatus

7.1 *ASTM Lamp Assembly*—Use the apparatus specified in Test Method **D1266**, including the liquefied petroleum gas burner assembly.

8. Reagents

8.1 Use the necessary reagents and materials specified in Test Method **D1266**, in addition to the absorber solution as described in **8.3**.

8.2 *Hydrogen* (**Warning**)—Extremely flammable (liquefied) gas under pressure. See Annex **A1.1**.)

8.3 *Sodium Carbonate Absorbent* (2 g/L)— Dissolve 2.0 g of anhydrous sodium carbonate (Na_2CO_3) in water and dilute to a litre with water.

9. Procedure

9.1 Prepare the combustion apparatus as described in Section 7 of Test Method **D1266**, Preparation of Apparatus, using 35 mL of Na_2CO_3 solution to charge the absorber.

9.2 Weigh the vessel containing the sample to the nearest 0.1 g. Support the sample vessel in an upright position so that the sample is burned from the gaseous phase. Connect the sample vessel to the auxiliary corrosion-resistant regulating valve by means of corrosion-resistant metal tubing (**Fig. 1**) (**Note 2**). Connect the bottom valve of the sample vessel to the regulated hydrogen supply. By means of short lengths of chloride-free rubber tubing, connect the auxiliary valve outlet to the side inlet of the gas burner and the lower inlet of the gas burner (Test Method **D1266**, Annex A3, Apparatus Detail, **Fig. 5**) to the burner manifold.

NOTE 2—For steady burning, it may be necessary to surround the auxiliary valve with a heat-exchanger system. A convenient means is winding insulated heating wire, having a resistance of 40 to 60 Ω , around the auxiliary valve and connecting it to a suitable rheostat. Another means is to place the regulating valve in a suitable metal beaker and cover the valve body with water maintained at 60 to 80°C.

9.3 Open the valve on the sample vessel; then open the auxiliary valve to allow a small stream of vapor to escape. Quickly light the burner. Adjust the flow of CO_2 - O_2 mixture and the sample so that the flame is approximately 35 mm high and clear blue in color; this color is reached just beyond the point at which a yellow color shows at the tip of the flame. Insert the burner into the chimney and readjust the flame if necessary. When the sample has burned almost to completion, open the valve on the bottom of the sample vessel and flush the residual sample from the cylinder chamber by passing hydrogen through the bottom valve for several minutes.

³ *Reagent Chemicals, American Chemical Society Specifications*, American Chemical Society, Washington, DC. For Suggestions on the testing of reagents not listed by the American Chemical Society, see *Annual Standards for Laboratory Chemicals*, BDH Ltd., Poole, Dorset, U.K., and the *United States Pharmacopeia and National Formulary*, U.S. Pharmacopeial Convention, Inc. (USPC), Rockville, MD.

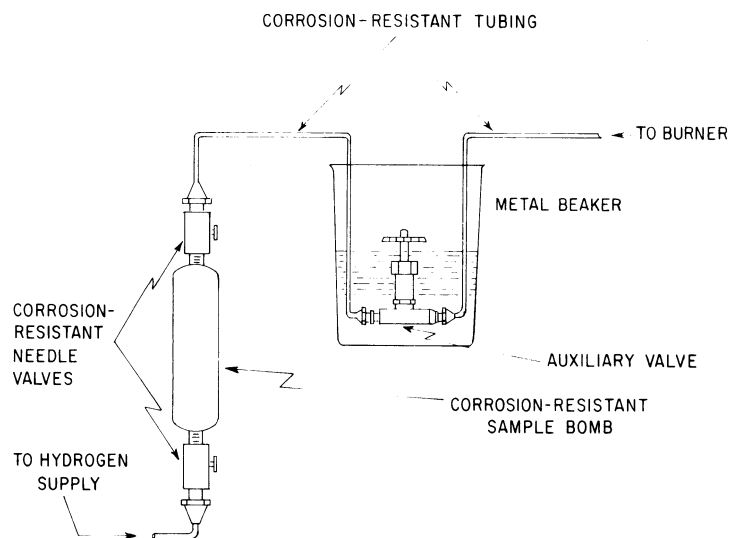

FIG. 1 Diagrammatic Sketch of Butane-Butene Heat Exchange System

9.4 When all of the residual material has been flushed from the sample vessel, turn off the hydrogen and close the valves on the sample vessel. Disconnect the hydrogen flushing line and the line to the heated auxiliary valve and weigh the sample vessel to the nearest 0.1 g. Draw the combustion atmosphere through one absorber of a set to serve as a blank on the purity of this atmosphere. Rinse the chimneys and spray traps with water and add the rinsings to the absorbers.

9.5 Proceed in accordance with either Section 16 or 21.

OXY-HYDROGEN COMBUSTION TEST METHOD— ALTERNATIVE TEST METHOD

10. Apparatus

10.1 *Oxy-Hydrogen Burner*⁴—A flow diagram of a typical apparatus is shown in Fig. 2. The apparatus shall consist of three parts: atomizer-burner, combustion chamber, and receiver with spray trap. A blowout safety port in the combustion chamber is desirable. The remainder of the apparatus shall consist of a steel support stand with the necessary needle valves and flow meters for precise control of air, oxygen, hydrogen, and vacuum. D2384-83(2014)

10.2 *Vacuum Pump*, having a capacity of at least 1200 L/h, and protected from corrosive fumes by suitable traps. 832014

11. Reagents and Materials

11.1 *Hydrogen* (**Warning**—Extremely flammable (liquefied) gas under pressure. See Annex A1.1.)

11.2 *Oxygen* (**Warning**—Oxygen vigorously accelerates combustion. See Annex A1.2.)

11.3 *Sodium Carbonate, Absorbent* (2g/L)—See 8.3.

12. Procedure

12.1 Follow the manufacturer's instructions for preparing and operating the apparatus. Place 50 mL of the Na₂CO₃ absorbent in the absorber. Burn all of the sample from the gas phase of the cylinder (Fig. 1). (**Warning** —Extremely flammable (liquefied) gas under pressure. See Annex A1.1.) Flush the residual gases from the cylinder chamber by passing hydrogen through the bottom valve for several minutes, burning the flushed gases.)

12.2 When combustion is completed, rinse all water-cooled portions of the apparatus and the spray trap with a spray of water. Collect all rinsings in the absorbent.

12.3 Proceed in accordance with either Section 16 or 21.

12.4 Prepare a blank by placing 50 mL of the Na₂CO₃ absorbent in the absorber. Operate the apparatus for the same period of time, under the same conditions that were used for the combustion of the sample, but without a sample and the sample inlet closed to the atmosphere. Burn approximately the same volume of hydrogen as was used to flush the same cylinder. When combustion

⁴ The Wickbold Burner Apparatus obtainable from the Atlas Instrument Co., 8902 E. 11th St., Tulsa, OK, or the Richfield Burner Apparatus obtainable from the Greiner Glass Blowing Laboratories, 3604 E. Medford St., Los Angeles, CA 90034, has been found suitable for this purpose. If you are aware of alternative suppliers, please provide this information to ASTM International Headquarters. Your comments will receive careful consideration at a meeting of the responsible technical committee,¹ which you may attend.

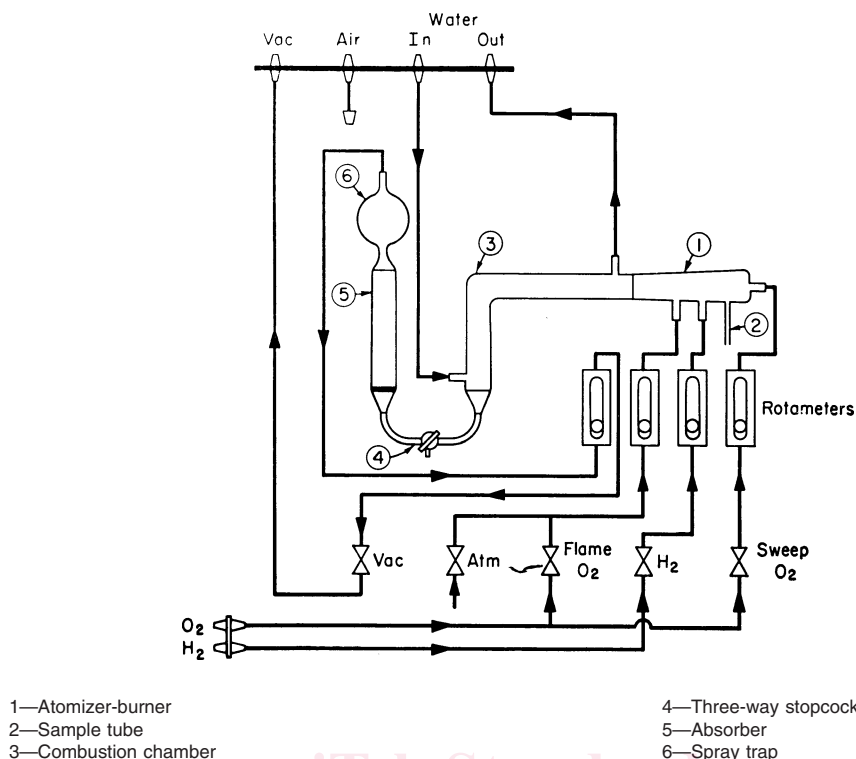

FIG. 2 Flow Diagram of a Typical Oxy-Hydrogen Combustion Apparatus

of the hydrogen is complete, rinse all water-cooled portions of the apparatus and the spray trap with a spray of water. Collect all rinsings in the absorbent. Proceed as in 12.3.

AMPEROMETRIC TITRATION FINISH

13. Apparatus

13.1 *Potentiometer-Galvanometer Assembly*, capable of applying a cell potential up to 3 V with an accuracy of 1 % of full scale, and capable of indicating the cell current by means of a galvanometer having a sensitivity of 0.005 to 0.008 $\mu\text{A}/\text{mm}$ scale division. A multiposition galvanometer shunt for adjustment of current measurement sensitivity should also be provided; shunt ratios to give sensitivities of approximately 0.05 to 0.08, and 0.10 to 0.16 $\mu\text{A}/\text{mm}$ should be included.

13.2 *Titration Assembly*—An apparatus similar to that shown in Fig. 3, consisting of a rotating (600 rpm) platinum electrode, a saturated calomel reference electrode with salt bridge, a means of blanketing the solution with nitrogen, and a holder for a 10-mL buret.

13.3 *Calomel Electrode*, constructed as shown in Fig. 3.

13.4 *Platinum Electrode*, rotating-hook type. A suitable electrode may be constructed as follows: Seal a platinum wire 0.03 to 0.05 in. (0.76 to 1.3 mm) in diameter and 0.75 to 1.0 in. (19.1 to 25.4 mm) long into the end of a 6-mm outside diameter soft glass tube that has been shaped into a stirrer blade. Bend the extending platinum wire upwards at its midpoint to form an angle of 90° . Place a few drops of mercury in the glass tube and make electrical contact between the mercury and the connection on the amperometric titrator with a piece of copper wire (insulate the exposed wire to prevent shorting).

13.5 *Buret*—A 10-mL semi-micro buret, with the tip constructed so as to be able to dip below the surface of the solution being titrated.

14. Reagents

14.1 *Acetone (99.5 %)* (**Warning**—Extremely flammable. Vapor may cause fire. See Annex A1.3.)—Refined acetone conforming to Specifications D329.

14.2 *Agar Solution*—Dissolve 2 g of agar-agar powder in 100 mL of hot water (80 to 100°C) containing 20 g of potassium nitrate (KNO_3).

14.3 *Bromthymol Blue Indicator Solution*—Dissolve 0.10 g of the solid indicator in 100 mL of hot water, cool, and add 1 mL of chloroform as a preservative. Discard the solution when it is 1 week old.

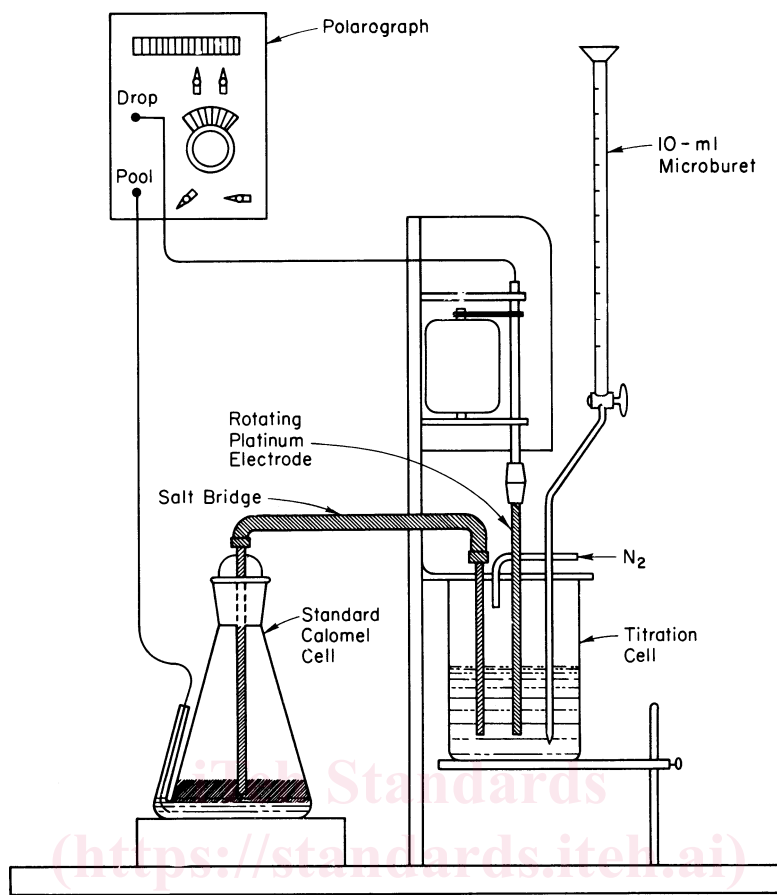

FIG. 3 Schematic Assembly of the Amperometric Titration Cell

NOTE 3—Remove possible objectionable amounts of chloride by passing the solution through an ion-exchange resin in the hydroxyl form. Neutralize the resulting alkaline solution to the bromthymol blue end point by titration with HNO₃ (3 + 97).

14.4 *Chloride, Standard Solution* (10 µg Cl⁻/mL)—Dilute a suitable volume of 1 + 10 assayed hydrochloric acid to obtain a solution containing 10 µg Cl⁻/mL.

14.5 *Gelatin Solution* (10 g/L)—Dissolve 1 g of gelatin in 100 mL of hot water and add 1 mL of chloroform as a preservative. Discard the solution when it is 1 week old.

14.6 *Hydrogen Peroxide Solution*—Prepare by diluting 1 volume of concentrated hydrogen peroxide solution (H₂O₂, 30 %) with 4 volumes of water. Store in a dark-colored glass-stoppered bottle.

14.7 *Mercury-Calomel Mixture*—Prepare a mixture of mercury and calomel (mercurous chloride, Hg₂Cl₂) by vigorously shaking 10 g of calomel with 50 g of mercury, in a glass-stoppered flask, until the calomel becomes uniformly gray in color. (**Warning**—Poison: May be harmful or fatal if inhaled or swallowed. Vapor harmful, emits toxic fumes when heated. Vapor pressure normal room temperature exceeds threshold limit value for occupational exposure. See Annex A1.4.)

14.8 *Nitric Acid* (sp gr 1.42)—Concentrated nitric acid (HNO₃). Bubble nitrogen through the acid until it is colorless, in order to remove oxides of nitrogen.

14.9 *Nitric Acid Solution* (1 + 28) —Mix 1 volume of concentrated nitric acid (HNO₃, sp gr 1.42) with 28 volumes of water.

14.10 *Nitrogen*, oxygen-free tank nitrogen. (**Warning**—Compressed gas under high pressure. Gas reduces oxygen available for breathing. See Annex A1.5.)

14.11 *Potassium Nitrate Solution* (100 g/L)—Dissolve 100 g of potassium nitrate (KNO₃) in water and dilute to 1 L with water.

14.12 *Potassium Nitrate, Saturated Solution*—Prepare a saturated solution of KNO₃ in water.

14.13 *Saturated Calomel Electrolyte*— Prepare a solution, saturated with calomel and potassium chloride (KCl), in water.

14.14 *Silver Nitrate Solution, Standard* (0.1N)—Prepare and standardize a 0.1 N solution of silver nitrate (AgNO₃) against primary standard sodium chloride crystals.

TABLE 1 Titration Conditions

Materials and Operations	Expected Chloride Content	
	Below 15 ppm	Above 15 ppm
Volume before addition of acetone, mL	10	25
Acetone, mL	20	25
Concentrated HNO ₃ , mL	1	2
Gelatin solution (10 g/L), mL	0.3	0.5
Galvanometer sensitivity, $\mu\text{A}/\text{mm}$	0.05 to 0.08	0.10 to 0.16
Normality of AgNO ₃ solution	0.001	0.01
Titrant addition increments, mL	0.25	0.05 to 0.10

14.15 *Silver Nitrate Solution, Standard (0.01N)*—Dilute ~~100 mL~~ 100 mL of 0.1 N AgNO₃ to 1 L with water.

14.16 *Silver Nitrate Solution, Standard (0.001N)*—Dilute 10.0 mL of 0.1 N AgNO₃ to 1 L with water.

14.17 *Sodium Carbonate Solution (2 g/L)*—Dissolve 2 g of granular anhydrous sodium carbonate (Na₂CO₃) in water and dilute to 1 L with water.

15. Preparation of Apparatus

15.1 *Platinum Electrode*—Clean the electrode by immersing it in concentrated HNO₃ (sp gr 1.42) and washing with water. Install the electrode on the amperometric titrator so that the end of the heavy copper wire dips into the mercury column of the platinum electrode.

15.2 *Saturated Calomel Reference Electrode*—Add sufficient mercury to the electrode flask to cover the platinum wire and to form a mercury seal between the flask and the side arm. Cover the mercury with a 5-mm layer of the mercury-calomel mixture and then fill the cell to within 20 mm of the glass joint with the saturated calomel electrolyte solution. Make electrical contact between the mercury and the connection on the amperometric titrator with a piece of copper wire (insulate the exposed wire to prevent shorting).

15.3 *Salt Bridge*—Connect the inner glass tube of the salt bridge to the inlet tube of the reference electrode by means of a 1-ft (305-mm) section of 6-mm inside diameter polyethylene tubing; clamp the two glass tubes in a vertical position. Fill the entire bridge with warm agar solution, taking care that no bubbles remain in the column of liquid. Close the open ends of the glass tubes with small pieces of loosely rolled filter paper and allow to stand until the solution is gelled. Insert the reference electrode inlet of the bridge into the electrode flask, and the other end through the front panel of the amperometric titrator and into the sleeve tube; fill the sleeve tube with a saturated solution of KNO₃.

NOTE 4—When the amperometric titration apparatus is not in use, immerse the end of the salt bridge and the platinum electrode in the beaker containing saturated KNO₃ solution.

<https://standards.iteh.ai/catalog/standards/sist/fd3c6f38-8202-4373-aae3-8ed14f5d8553/astm-d2384-832014>

16. Procedure

16.1 Transfer the absorber solution from either the lamp or oxy-hydrogen combustion to a 200-mL tall-form titration beaker and reduce its volume to 10 mL if the expected chloride content is less than 15 ppm and to about 25 mL if above ~~15 ppm~~ 15 ppm (see Table 1).

16.2 Add the amount of acetone, HNO₃, and gelatin solution shown in Table 1.

16.3 Place the beaker in position at the rotating platinum electrode assembly and adjust the sensitivity shunt in accordance with the values given in Table 1. Turn the stirring motor on. Adjust the potential divider so that -0.23 ± 0.02 V is applied to the platinum electrode. Maintain this potential throughout the titration. Allow the galvanometer to stabilize at 1 $\mu\text{A}/\text{mm}$ or less; the time needed to achieve this can be markedly reduced by purging the solution with nitrogen. Record the galvanometer reading.

16.4 Add AgNO₃ solution (Table 1) until the galvanometer shows a deflection of 30 to 40 scale divisions. When the galvanometer becomes steady, record the buret and galvanometer readings. Continue adding AgNO₃ solution in suitable increments (Table 1); after each addition allow the galvanometer to stabilize and record the buret and galvanometer readings. Stop the flow of nitrogen while taking galvanometer readings. Continue the titration until three or four additional points have been obtained to establish a slope.

17. Calculations

17.1 Plot the galvanometer readings against the corresponding volumes of AgNO₃ solution added and draw the best straight line through these points. Draw a second straight line parallel to the milliliter axis and passing through the galvanometer reading obtained with no added AgNO₃ solution. The volume of AgNO₃ solution corresponding to the intersection of these lines represents the volume of reagent used by the sample.

NOTE 5—A typical amperometric titration curve (see Fig. 4) consists of two linear branches and an intermediate curving region. The first linear portion corresponds to the reaction of the substance being titrated with the titrating solution and, since excess titrant is never present, the diffusion current remains