



Designation: **C1231/C1231M – 13 C1231/C1231M – 14**

Standard Practice for Use of Unbonded Caps in Determination of Compressive Strength of Hardened Concrete Cylinders¹

This standard is issued under the fixed designation C1231/C1231M; the number immediately following the designation indicates the year of original adoption or, in the case of revision, the year of last revision. A number in parentheses indicates the year of last reappraisal. A superscript epsilon (ϵ) indicates an editorial change since the last revision or reappraisal.

1. Scope*

1.1 This practice covers requirements for a capping system using unbonded caps for testing concrete cylinders molded in accordance with Practice **C31/C31M** or **C192/C192M**. *Unbonded neoprene caps of a defined hardness are permitted to be used for testing for a specified maximum number of reuses without qualification testing up to a certain concrete compressive strength level. Above that strength, level neoprene caps will require qualification testing. Qualification testing is required for all elastomeric materials other than neoprene regardless of the concrete strength.*

1.2 Unbonded caps are not to be used for acceptance testing of concrete with compressive strength below ~~1500 psi [10 MPa]~~ or above ~~12 000 psi [80 MPa]~~. ~~10 MPa [1500 psi]~~ or above 80 MPa [12 000 psi].

1.3 The values stated in either SI units or inch-pound units are to be regarded separately as standard. The values stated in each system may not be exact equivalents; therefore, each system shall be used independently of the other. Combining values from the two systems may result in non-conformance with the standard.

1.4 *This standard does not purport to address all of the safety concerns, if any, associated with its use. It is the responsibility of the user of this standard to establish appropriate safety and health practices and determine the applicability of regulatory limitations prior to use. (Warning—Concrete cylinders tested with unbonded caps rupture more violently than comparable cylinders tested with bonded caps. The safety precautions given in the Manual of Aggregate and Concrete Testing are recommended.)* ~~Warning—Concrete cylinders tested with unbonded caps rupture more violently than comparable cylinders tested with bonded caps. The safety precautions given in the Manual of Aggregate and Concrete Testing are recommended.)~~

2. Referenced Documents

2.1 *ASTM Standards:*³

C31/C31M Practice for Making and Curing Concrete Test Specimens in the Field

C39/C39M Test Method for Compressive Strength of Cylindrical Concrete Specimens [25c65430/astm-c1231-c1231m-14](https://doi.org/10.1520/25c65430/astm-c1231-c1231m-14)

C192/C192M Practice for Making and Curing Concrete Test Specimens in the Laboratory

C617 Practice for Capping Cylindrical Concrete Specimens

D2000 Classification System for Rubber Products in Automotive Applications

3. Terminology

3.1 *Definitions of Terms Specific to This Standard:*

3.1.1 *pad, n*—an unbonded elastomeric pad.

3.1.2 *unbonded cap, n*—a metal retainer and an elastomeric pad.

4. Significance and Use

4.1 This practice provides for using an unbonded capping system in testing hardened concrete cylinders made in accordance with Practices **C31/C31M** or **C192/C192M** in lieu of the capping systems described in Practice **C617**.

¹ This practice is under the jurisdiction of ASTM Committee C09 on Concrete and Concrete Aggregates and is the direct responsibility of Subcommittee C09.61 on Testing for Strength.

Current edition approved Dec. 15, 2013/July 1, 2014. Published January 2014/July 2014. Originally approved in 1993. Last previous edition approved in 2012/2013 as C1231/C1231M-12. DOI: 10.1520/C1231-C1231M-13. DOI: 10.1520/C1231-C1231M-14.

² Section on Safety Precautions, Manual of Aggregate and Concrete Testing, *Annual Book of ASTM Standards*, Vol. 04.02.

³ For referenced ASTM standards, visit the ASTM website, www.astm.org, or contact ASTM Customer Service at service@astm.org. For *Annual Book of ASTM Standards* volume information, refer to the standard's Document Summary page on the ASTM website.

*A Summary of Changes section appears at the end of this standard

4.2 The elastomeric pads deform in initial loading to conform to the contour of the ends of the cylinder and are restrained from excessive lateral spreading by plates and metal rings to provide a uniform distribution of load from the bearing blocks of the testing machine to the ends of the concrete or mortar cylinders.

5. Materials and Apparatus

5.1 Materials and equipment necessary to produce ends of the reference cylinders that conform to planeness requirements of Test Method **C39/C39M** and the requirements of Practice **C617**. This may include grinding equipment or capping materials and equipment to produce neat cement paste, high strength gypsum plaster, or sulfur mortar caps.

5.2 Elastomeric Pads:

5.2.1 Pads shall be $13 \pm 2 \text{ mm}$ [$\frac{1}{2} \pm \frac{1}{16} \text{ in.}$ [$13 \pm 2 \text{ mm}$] in.] thick and the diameter shall not be more than 2 mm [$\frac{1}{16} \text{ in.}$ [2 mm] in.] smaller than the inside diameter of the retaining ring.

5.2.2 Pads shall be made from polychloroprene (neoprene) meeting the requirements of Classification **D2000** as follows:

Shore A Durometer	Classification D2000 Line Call-Out
50	M2BC514
60	M2BC614
70	M2BC714

The tolerance on Shore A durometer hardness is ± 5 . **Table 1** provides requirements for use of caps made from material meeting the requirements of Classification **D2000**, above.

5.2.3 Other elastomeric materials that meet the performance requirements of qualification tests in Section 8 are permitted.

5.2.4 Elastomeric pads shall be supplied with the following information:

5.2.4.1 The manufacturer's or supplier's name,

5.2.4.2 The Shore A hardness, and

5.2.4.3 The applicable range of concrete compressive strength from **Table 1** or from qualification testing.

5.2.5 The user shall maintain a record indicating the date the pads are placed in service, the pad durometer, and the number of uses to which they have been subjected.

5.3 *Retainers*, are a pair of metal fixtures used to provide support for and alignment of the neoprene pads and the cylinder ends (**Note 1** and **Fig. 1**). Each retainer (upper and lower) includes a (retaining) ring that is welded to or manufactured integrally with a base plate. The height of the retaining ring shall be $25 \pm 3 \text{ mm}$ [$1.0 \pm 0.1 \text{ in.}$]. The inside diameter of the retaining ring shall not be less than 102 % or greater than 107 % of the diameter of the cylinder. The thickness of the retaining ring shall be at least 12 mm [0.47 in.] for 150 mm [6 in.] diameter retainers and at least 9 mm [0.35 in.] for 100 mm [4 in.] diameter retainers. The surface of the base plate that contacts the bearing block of the testing machine shall be plane to within 0.05 mm [0.002 in.]. The thickness of the base plate shall be at least 12 mm [0.47 in.] for 150 mm [6 in.] retainers and at least 8 mm [0.3 in.] for 100 mm [4 in.] retainers. The bearing surfaces of the retainers shall not have gouges, grooves, protrusions, or indentations greater than 0.25 mm [0.010 in.] deep or greater than 32 mm^2 [0.05 in.²] in surface area.

TABLE 1 Requirements for Use of Polychloroprene(Neoprene) Pads

Compressive Strength, ^A ψ [MPa]	Shore A Durometer Hardness	Qualification Tests Required	Maximum Reuses ^B
Less than 1500 [10]		Not permitted	
1500 to 6000 [10 to 40]	50	None	100
2500 to 7000 [17 to 50]	60	None	100
4000 to 7000 [28 to 50]	70	None	100
7000 to 12,000 [50 to 80]	70	Required	50
Greater than 12,000 [80]		Not permitted	

TABLE 1 Requirements for Use of Polychloroprene(Neoprene) Pads

Compressive Strength, ^A MPa [ψ]	Shore A Durometer Hardness	Qualification Tests Required	Maximum Reuses
Less than 10 [1 500]		Not permitted	
10 to 40 [1 500 to 6 000]	50	None	100
17 to 50 [2 500 to 7 000]	60	None	100
28 to 50 [4 000 to 7 000]	70	None	100
50 to 80 [7 000 to 12 000]	70	Required	50
Greater than 80 [12 000]		Not permitted	

^A Compressive strength of concrete at age of testing as specified in Contract Documents. For acceptance testing, it is the specified compressive strength f'_c .

^B Maximum number of reuses will be less if pads wear, crack or split. See 7.2.

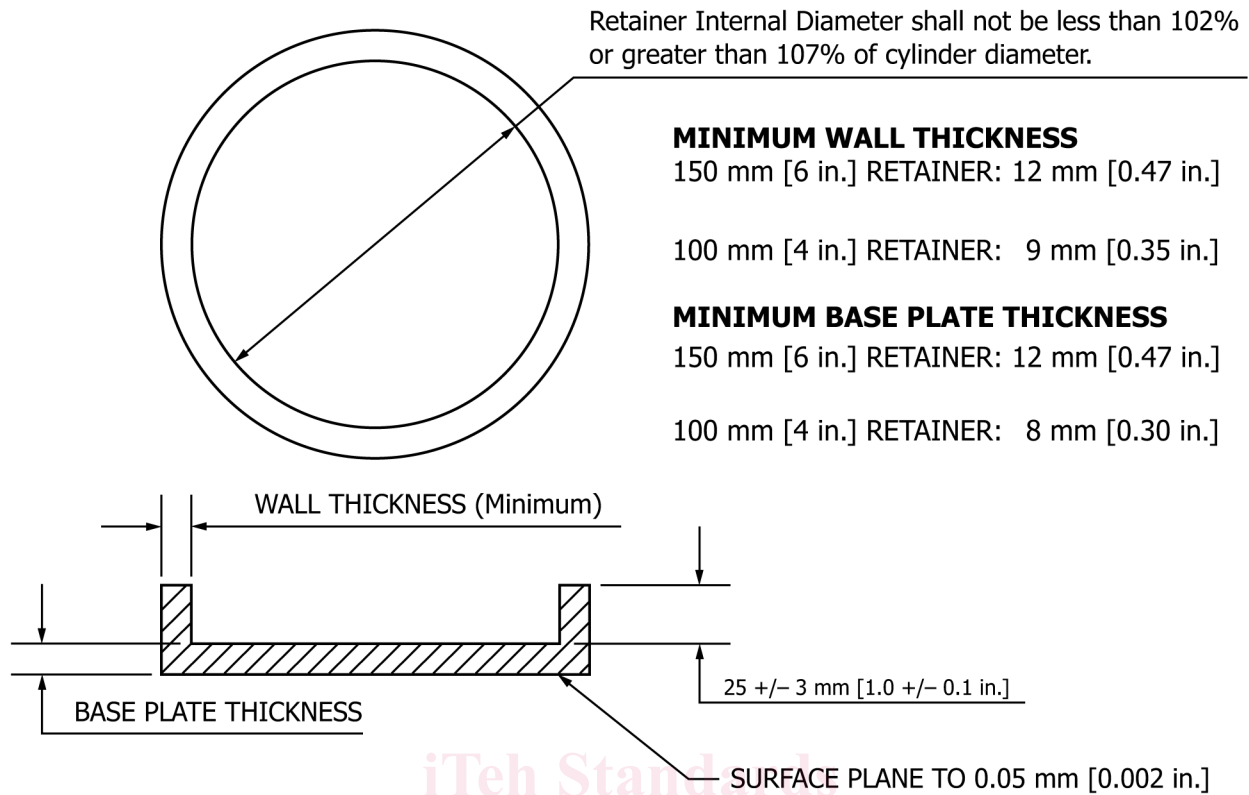

FIG. 1 Example of Retaining Ring and Base Plate

NOTE 1—Retainers made from steel and some aluminum alloys have been found acceptable.

6. Test Specimens

6.1 The specimens shall be either 6 by 12 in. [150 by 300 mm] or 4 by 8 in. [100 by 200 mm] 150 by 300 mm [6 by 12 in.] or 100 by 200 mm [4 by 8 in.] cylinders made in accordance with Practices C31/C31M or C192/C192M. Neither end of a cylinder shall depart from perpendicularity to the axis by more than 0.5° (Note 2). No individual diameter of a cylinder may differ from any other diameter by more than 2%.

NOTE 2—One method of measuring the perpendicularity of ends of cylinders is to place a try square across any diameter and measure the departure of the longer blade from an element of the cylindrical surface. An alternative method is to place the end of the cylinder on a plane surface and support the try square on that surface. A deviation from perpendicularity of 0.5° is equal to a slope of approximately 1 mm in 100 mm [1/8 in. in 12 in.]

6.2 Depressions under a straight edge measured with a round wire gage across any diameter shall not exceed 0.20 in. [5 mm] 5 mm [0.20 in.]. If cylinder ends do not meet this tolerance, the cylinder shall not be tested unless irregularities are corrected by sawing or grinding.

7. Procedure

7.1 Unbonded caps are permitted to be used on one or both ends of a cylinder in lieu of a cap or caps meeting Practice C617, provided the caps meet the requirements of Section 5. Pad hardness shall be in accordance with Table 1. (Note 3)

NOTE 3—The specified strength in the contract documents is for various stages of construction. This may include strength test requirements for formwork removal or release of prestress in addition to the test requirements for verification of specified compressive strength. Therefore, pad selection is based on the strength requirement for the designated stage of construction.

NOTE 3—The specified strength in the contract documents is for various stages of construction. This may include strength test requirements for formwork removal or release of prestress in addition to the test requirements for verification of specified compressive strength. Therefore, pad selection is based on the strength requirement for the designated stage of construction.

7.2 Examine both sides of pads for excessive wear or damage. Replace pads that have cracks or splits in their top or do not meet the dimensional requirements of 5.2 bottom surface or that exceed 3/8 in. [10 mm] in length regardless the maximum reuse limits of Table 1 depth. Insert pad in the retainer before it is placed on the cylinder (cylinder, Note 4).

NOTE 4—Some manufacturers recommend dusting the pads and the ends of the cylinders with corn starch or talcum powder prior to testing.

7.3 Complete the load application, testing, calculation, and reporting of results in accordance with Test Method C39/C39M (Notes 5 and 6).

NOTE 5—Some users have reported damage to testing machines from the sudden release of energy stored in the elastomeric pads.

NOTE 6—Occasionally, unbonded capped cylinders may develop early cracking, but continue to carry increasing load. For this reason Test Method C39/C39M requires cylinders to be loaded until it is certain that they have been compressed beyond their ultimate capacity.

8. Qualification of Unbonded Capping Systems and Verification of Reuse of Pads

8.1 Table 1 specifies the conditions under which polychloroprene (neoprene) unbonded pads must be qualified under this section depending on the concrete strength and the Shore A hardness. Unbonded pads made of other elastomeric materials must be qualified using the procedures in this section.

8.2 When qualification tests are required they must be made by either the supplier or user of the unbonded pads. The user of the pads must retain a copy of the current qualification test report to demonstrate compliance with this practice. See X1.1.

8.3 The compressive strength of molded cylinders tested with unbonded caps shall be compared with that of companion cylinders tested with ends ground or capped to meet requirements of Test Method C39/C39M and Practice C617.

8.4 To be acceptable, tests must demonstrate that at a 95 % confidence level ($\alpha = 0.05$), the average strength obtained using unbonded caps is not less than 98 % of the average strength of companion cylinders capped or ground in accordance with 8.3.

8.4.1 When required, qualification tests in accordance with 8.5 shall be made on initial use of an unbonded cap at both the highest and lowest strength levels anticipated to establish an acceptable range of cylinder strength for use. In practice individual cylinders shall not have strengths more than 10 % greater than the high strength level or more than 10 % less than the low strength level qualified or specified in Table 1. Qualification tests shall be repeated whenever there is a change in the design or dimensions of the retaining rings, or when there is a change in pad composition or thickness, or the Shore A hardness changes by more than five units. Initial qualification tests shall include verification that after the specified maximum number of reuses the pads meet the requirements of 8.4.

8.4.2 When tests are made to establish a permissible number of reuses exceeding those in Table 1, only those tests or reuses which are within ~~2000 psi~~ [14 MPa] 14 MPa [2000 psi] of the highest strength level to be qualified will be included in the reuse count. Laboratories must maintain records of the number of times pads are reused.

NOTE 7—Pad life depends on the hardness and type of pad material, the strength of the concrete, the difference between the outside diameter of the cylinder and the inside diameter of the retaining ring, the unevenness and roughness of the ends of the cylinder, and other factors. Based on available information, scuffing or abrasion of the perimeter of the pad is normal, provided it does not reduce the thickness of the pad around the perimeter.

8.5 Specimen Preparation for Qualification and Pad Reuse Testing:

8.5.1 Pairs of individual cylinders shall be made from a sample of concrete and cured as nearly alike as possible: one cylinder per pair is to be tested after grinding or capping in accordance with 8.3 and the other is to be tested using the unbonded cap system.

8.5.2 A minimum of 10 pairs of cylinders shall be made at both the highest and lowest strength levels desired or anticipated (Note 8). The “strength level” is the average of the strengths of the 20 or more cylinders whose strengths are within a range of ~~1000 psi~~ [7 MPa] 7 MPa [1000 psi] (Note 9). More than one pair of cylinders can be made from a single concrete sample, but cylinders must come from a minimum of two samples made on different days for each concrete strength level (Note 10).

NOTE 8—If the Practice C617 capped and unbonded capped specimens produce equal strengths, the number of pairs of cylinders that will be needed to demonstrate compliance will range from 9 to more than 60 depending on the variability of test results. If the two capping systems produce equal strengths, about 10 % of laboratories will require more than 60 tests and 10 % of the laboratories will require 9 tests to demonstrate statistical compliance.

NOTE 9—Note that the range of strengths permitted in qualification testing to define the strength level is ~~1000 psi~~ [7 MPa] 7 MPa [1000 psi], but that in counting number of reuses only cylinders within a range of ~~2000 psi~~ [14 MPa] 14 MPa [2000 psi] are included in the reuse count.

NOTE 10—Cylinders for qualification tests can be from pairs of cylinders tested in routine laboratory operations and, in most instances, special trial batches should not be required for qualification tests.

9. Calculation

9.1 For each strength level, compute the difference in strength for each pair of cylinders, and compute the average strength of the cylinders with reference caps and the average strength of the cylinders with unbonded caps, as follows:

$$d_i = x_{pi} - x_{si} \quad (1)$$

$$\bar{x}_s = (x_{s1} + x_{s2} + x_{s3} \dots + x_{sm}) / m$$

$$\bar{x}_p = (x_{p1} + x_{p2} + x_{p3} \dots + x_{pn}) / n$$

where:

d_i = difference in strength of a pair of cylinders computed as the strength of unbonded capped cylinder minus the strength of the cylinder prepared according to Practice C617 (may be positive or negative),

x_{pi} = cylinder strength using unbonded cap,

x_{si} = cylinder strength using Practice C617,

n = number of pairs of cylinders tested for the strength level,

\bar{x}_s = average strength of Practice C617 capped cylinders for a strength level, and

\bar{x}_p = average strength of unbonded cap cylinders for a strength level.