



Designation: D1552 – 08(Reapproved 2014)

Standard Test Method for Sulfur in Petroleum Products (High-Temperature Method)¹

This standard is issued under the fixed designation D1552; the number immediately following the designation indicates the year of original adoption or, in the case of revision, the year of last revision. A number in parentheses indicates the year of last reapproval. A superscript epsilon (ϵ) indicates an editorial change since the last revision or reapproval.

This standard has been approved for use by agencies of the U.S. Department of Defense.

1. Scope

1.1 This test method covers three procedures for the determination of total sulfur in petroleum products including lubricating oils containing additives, and in additive concentrates. This test method is applicable to samples boiling above 177°C (350°F) and containing not less than 0.06 mass % sulfur. Two of the three procedures use iodate detection; one employing an induction furnace for pyrolysis, the other a resistance furnace. The third procedure uses IR detection following pyrolysis in a resistance furnace.

1.2 Petroleum coke containing up to 8 mass % sulfur can be analyzed.

1.3 The values stated in SI units are to be regarded as the standard. The values given in parentheses are for information only.

1.4 *This standard does not purport to address all of the safety concerns, if any, associated with its use. It is the responsibility of the user of this standard to establish appropriate safety and health practices and determine the applicability of regulatory limitations prior to use.*

2. Referenced Documents

2.1 *ASTM Standards:*²

D1193 Specification for Reagent Water

D1266 Test Method for Sulfur in Petroleum Products (Lamp Method)

D4057 Practice for Manual Sampling of Petroleum and Petroleum Products

D6299 Practice for Applying Statistical Quality Assurance and Control Charting Techniques to Evaluate Analytical Measurement System Performance

¹ This test method is under the jurisdiction of ASTM Committee D02 on Petroleum Products, Liquid Fuels, and Lubricants and is the direct responsibility of Subcommittee D02.03 on Elemental Analysis.

Current edition approved June 15, 2014. Published July 2014. Originally approved in 1958. Last previous edition approved in 2008 as D1552–08. DOI: 10.1520/D1552-08R14.

² For referenced ASTM standards, visit the ASTM website, www.astm.org, or contact ASTM Customer Service at service@astm.org. For *Annual Book of ASTM Standards* volume information, refer to the standard's Document Summary page on the ASTM website.

D6792 Practice for Quality System in Petroleum Products and Lubricants Testing Laboratories

3. Summary of Test Method

3.1 *Iodate Detection System*—The sample is burned in a stream of oxygen at a sufficiently high temperature to convert about 97 % of the sulfur to sulfur dioxide. A standardization factor is employed to obtain accurate results. The combustion products are passed into an absorber containing an acid solution of potassium iodide and starch indicator. A faint blue color is developed in the absorber solution by the addition of standard potassium iodate solution. As combustion proceeds, bleaching the blue color, more iodate is added. The amount of standard iodate consumed during the combustion is a measure of the sulfur content of the sample.

3.2 *IR Detection System*—The sample is weighed into a special ceramic boat which is then placed into a combustion furnace at 1371°C (2500°F) in an oxygen atmosphere. Most sulfur present is combusted to SO₂ which is then measured with an infrared detector after moisture and dust are removed by traps. A microprocessor calculates the mass percent sulfur from the sample weight, the integrated detector signal and a predetermined calibration factor. Both the sample identification number and mass percent sulfur are then printed out. The calibration factor is determined using standards approximating the material to be analyzed.

4. Significance and Use

4.1 This test method provides a means of monitoring the sulfur level of various petroleum products and additives. This knowledge can be used to predict performance, handling, or processing properties. In some cases the presence of sulfur compounds is beneficial to the product and monitoring the depletion of sulfur can provide useful information. In other cases the presence of sulfur compounds is detrimental to the processing or use of the product.

5. Interferences

5.1 For the iodate systems, chlorine in concentrations less than 1 mass % does not interfere. The IR system can tolerate somewhat higher concentrations. Nitrogen when present in excess of 0.1 mass % may interfere with the iodate systems; the

extent of such interference may be dependent on the type of nitrogen compound as well as the combustion conditions. Nitrogen does not interfere with the IR system. The alkali and alkaline earth metals, as well as zinc, phosphorus, and lead, do not interfere with either system.

6. Apparatus

6.1 Combustion and Iodate Detection System:

6.1.1 *Furnaces*—Two major types are available, the primary difference being the manner in which the necessary high temperatures are obtained. These two types are as follows:

6.1.1.1 *Induction Type*, which depends upon the high-frequency electrical induction method of heating. This assembly shall be capable of attaining a temperature of at least 1482°C (2700°F) in the sample combustion zone, under the conditions set forth in 9.1 and shall be equipped with an additional induction coil located above the combustion zone, substantially as shown in Fig. 1.

6.1.1.2 The furnace work coil should have a minimum output of 500 W; the minimum input rating of the furnace must be 1000 W. With the correct amount of iron chips, weighed to ± 0.05 g, the maximum plate current will be between 350 and 450 mA. (**Warning**—This type of furnace is capable of inflicting high frequency burns and high-voltage shocks. In addition to other precautions, maintain all guards properly.) (**Warning**—Disconnect the furnace from the power line whenever electrical repairs or adjustments are made.)

6.1.1.3 *Resistance Type*, capable of maintaining a temperature of at least 1371°C (2500°F).

6.1.2 *Absorber*, as described in Test Method D1266.

NOTE 1—Also suitable for use with either type of furnace is an automatic titrator, specifically designed for iodometry. This combines the functions of absorption and titration to a predetermined end point.

6.1.3 *Buret*, standard 25-mL or automatic types available from the manufacturers of the specific combustion units, are suitable (Note 1).

6.2 *Combustion and IR Detection System*, comprised of automatic balance, oxygen flow controls, drying tubes, combustion furnace, infrared detector and microprocessor. The furnace shall be capable of maintaining a nominal operating temperature of 1350°C (2460°F).³

6.3 *Miscellaneous Apparatus*—Specific combustion assemblies require additional equipment such as crucibles, combustion boats, crucible lids, boat pushers, separator disks, combustion tubes, sample inserters, oxygen flow indicator, and oxygen drying trains. The additional equipment required is dependent on the type of furnace used and is available from the manufacturer of the specific combustion unit. To attain the lower sulfur concentration given in Section 1, the ceramics used with the induction furnace assembly shall be ignited in a muffle furnace at 1371°C (2500°F) for at least 4 h before use.

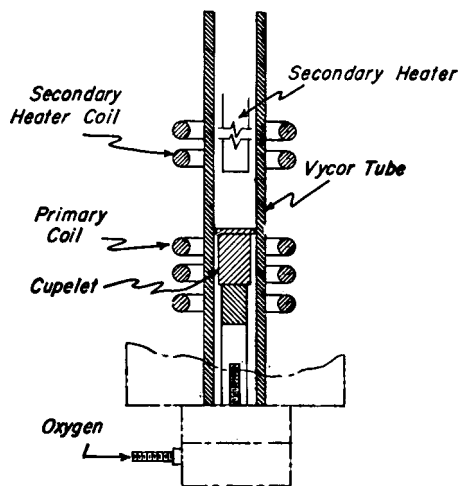

FIG. 1 Combustion Tube

6.4 *Sieve*, 60-mesh (250- μ m).

7. Reagents and Materials

7.1 *Purity of Reagents*—Reagent grade chemicals shall be used in all tests. Unless otherwise indicated, it is intended that all reagents shall conform to the specifications of the Committee on Analytical Reagents of the American Chemical Society, where such specifications are available.⁴ Other grades may be used, provided it is first ascertained that the reagent is of sufficiently high purity to permit its use without lessening the accuracy of the determination.

7.2 *Purity of Water*—Unless otherwise indicated, references to water shall be understood to mean reagent water as defined by Type II or III of Specification D1193.

7.3 *Alundum* (Al_2O_3) or *Magnesium Oxide* (Com-Aid).

7.4 *Anhydrone* (*Magnesium Perchlorate*). (**Warning**—In addition to other precautions, handle magnesium perchlorate with care. Avoid contacting it with acid and organic materials. Reactions with fuel may be violent.)

7.5 *Hydrochloric Acid* (3 + 197)—Dilute 30 mL of concentrated hydrochloric acid (HCl, relative density 1.19) to 2 L with water. (**Warning**—Poison. Corrosive. May be fatal if swallowed. Liquid and vapor cause severe burns.)

7.6 *Oxygen* (*Extra Dry*)—The oxygen shall be at least 99.5 % pure and show no detectable sulfur by blank determination. (**Warning**—Oxygen vigorously accelerates combustion.)

7.7 *Phosphorus Pentoxide*—(P_2O_5).

7.8 *Potassium Alum* (*Aluminum Potassium Sulfate*).

³ The sole source of supply of Models SC32 or SC132 known to the committee at this time is LECO Corp., 3800 Lakeview Ave., St. Joseph, MI 49085-2396. If you are aware of alternative suppliers, please provide this information to ASTM International Headquarters. Your comments will receive careful consideration at a meeting of the responsible technical committee,¹ which you may attend.

⁴ *Reagent Chemicals, American Chemical Society Specifications*, American Chemical Society, Washington, DC. For Suggestions on the testing of reagents not listed by the American Chemical Society, see *Annual Standards for Laboratory Chemicals*, BDH Ltd., Poole, Dorset, U.K., and the *United States Pharmacopeia and National Formulary*, U.S. Pharmacopeial Convention, Inc. (USPC), Rockville, MD.

7.9 *Potassium Iodate, Standard Solution* (0.06238 N), 1 mL of this solution is equivalent to 1 mg S)—Dissolve 2.225 g of potassium iodate (KIO_3) that has been dried at about 180°C to constant weight, in water and dilute to 1 L. Thoroughly mix the solution.

7.10 *Potassium Iodate, Standard Solution* (0.006238 N), 1 mL of this solution is equivalent to 0.1 mg S)—Measure exactly 100 mL of KIO_3 solution (0.06238 N) into a 1-L volumetric flask, and dilute to volume with water. Thoroughly mix the solution.

7.11 *Potassium Iodate, Standard Solution* (0.01248 N), 1 mL of this solution is equivalent to 0.2 mg S)—Measure exactly 200 mL of KIO_3 solution (0.06238 N) into a 1-L volumetric flask and dilute to volume with water. Thoroughly mix the solution.

7.12 *Ascarite*, 8 to 20 mesh.

7.13 *Special Materials for Induction-Type Furnaces:*

7.13.1 *Tin* (20 to 30-mesh).

7.13.2 *Iron-Chip Accelerator* having a sulfur content of not more than 0.005 mass %.

7.14 *Standard Sample*—Potassium alum ($\text{AlK}(\text{SO}_4)_2 \cdot 12\text{H}_2\text{O}$).

7.15 *Starch-Iodide Solution*—Make a paste by adding 9 g of soluble starch to 15 mL of water. Add this mixture, with stirring, to 500 mL of boiling water. Cool the mixture, add 15 g of potassium iodide (KI), and dilute to 1 L with water.

7.16 *Sulfuric Acid* (relative density 1.84)—Concentrated sulfuric acid (H_2SO_4). (**Warning**—Poison. Corrosive. Strong oxidizer.)

7.17 *Vanadium Pentoxide*, anhydrous, powdered V_2O_5 .

7.18 *Quality Control (QC) Sample(s)*, preferably are portions of one or more petroleum products that are stable and representative of the samples of interest. These QC samples can be used to check the validity of the testing process and performance of the instrument as described in Section 12.

8. Sampling

8.1 Take samples in accordance with the instructions in Practice D4057.

9. Preparation of Apparatus

9.1 *Induction-Type Furnace*—Assemble the apparatus according to the instructions furnished by the manufacturer. Purify the oxygen by passing it through (1) H_2SO_4 (relative density 1.84), (2) Ascarite, and (3) magnesium perchlorate ($\text{Mg}(\text{ClO}_4)_2$) or phosphorus pentoxide (P_2O_5) (**Warning**—see 7.4). Connect a rotameter between the purifying train and the furnace. Insert a small glass-wool plug in the upper end of the glass tubing connecting the furnace with the absorber to catch oxides of tin. Connect the exit end of the combustion tube to the absorber with glass tubing, using gum rubber tubing to make connections. Position the absorber so as to make this delivery line as short as possible. Fig. 2 illustrates schematically the assembled apparatus. Adjust the oxygen flow to 1 ± 0.05 L/min. Add 65 mL of HCl (3 + 197) and 2 mL of

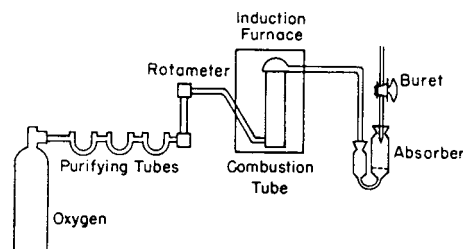

FIG. 2 Schematic Illustration of Induction-Type Furnace

starch-iodide solution to the absorber. Add a sufficient amount of the appropriate standard KIO_3 solution (Table 1) to produce a faint blue color. This color will serve as the end point for the titration. Adjust the buret to zero. Turn on the furnace filament switch and allow at least 1 min warm-up before running samples (**Warning**—see 7.4).

9.2 *Resistance-Type Furnace*—Assemble the apparatus according to the instructions furnished by the manufacturer. Purify the oxygen by passing it through (1) H_2SO_4 (relative density 1.84), (2) Ascarite, and (3) $\text{Mg}(\text{ClO}_4)_2$ or P_2O_5 (**Warning**—see 7.4). Connect a rotameter between the purifying train and the furnace. Fig. 3 illustrates schematically the assembled apparatus. Turn on the current and adjust the furnace control to maintain a constant temperature of $1316 \pm 14^\circ\text{C}$ ($2400 \pm 25^\circ\text{F}$). Adjust the oxygen flow rate to 2 ± 0.1 L/min. Add 65 mL of HCl (3 ± 197) and 2 mL of starch-iodide solution to the absorber. Add a few drops of the appropriate standard KIO_3 solution (Table 2) to produce a faint blue color. Adjust the buret to zero.

9.3 *Resistance-Type Furnace—IR Detection*—Assemble and adjust apparatus according to manufacturer's instructions. Initialize microprocessor, check power supplies, set oxygen pressure and flows and set furnace temperature to 1371°C (2500°F).

9.3.1 Condition a fresh anhydrous scrubber with four coal samples when analyzing petroleum coke samples, or with four petroleum product samples that are representative or typical of the sample types to be analyzed.

9.3.2 Calibrate the automatic balance according to manufacturer's instructions.

10. Standardization

10.1 *For Iodate Methods:*

10.1.1 *Determination of Alum Factor:*

10.1.1.1 Because these rapid combustion methods involve the reversible reaction $2\text{SO}_2 + \text{O}_2 = 2\text{SO}_3$, it is not possible to evolve all the sulfur as SO_2 . The equilibrium of the reaction is temperature dependent and, in an oxygen atmosphere above 1316°C , about 97 % of the sulfur is present as SO_2 . To assure that the furnace is in proper adjustment and that its operation produces acceptably high temperature, potassium alum is employed for standardizing the apparatus. Depending on the type of combustion equipment used, proceed as described in Sections 10 to 14 to determine the alum factor. Use 15 mg weighed to ± 0.1 mg of potassium alum for this determination. Use the same materials in the determination of the alum and standardization factors as for the unknown samples. For