



Designation: **D3104 – 99 (Reapproved 2010) D3104 – 14**

Standard Test Method for Softening Point of Pitches (Mettler Softening Point Method)¹

This standard is issued under the fixed designation D3104; the number immediately following the designation indicates the year of original adoption or, in the case of revision, the year of last revision. A number in parentheses indicates the year of last reapproval. A superscript epsilon (ϵ) indicates an editorial change since the last revision or reapproval.

1. Scope—Scope*

1.1 This test method covers the determination of the softening point of pitches having softening points in the range from 50 to 180°C by this test method, and gives results comparable to those obtained by Test Method **D2319** above 176°F (80°C).

1.2 The values stated in SI units are to be regarded as the standard.

1.3 *This standard does not purport to address all of the safety concerns, if any, associated with its use. It is the responsibility of the user of this standard to establish appropriate safety and health practices and determine the applicability of regulatory limitations prior to use.*

2. Referenced Documents

2.1 *ASTM Standards:*²

A314 Specification for Stainless Steel Billets and Bars for Forging

D2319 Test Method for Softening Point of Pitch (Cube-in-Air Method)

D4296 Practice for Sampling Pitch

3. Summary of Test Method

3.1 In this test method, the softening point is defined as the temperature at which pitch, suspended in a cylindrical cup with a 6.35-mm hole in the bottom, flows downward a distance of 19 mm to interrupt a light beam, as the sample is heated at a linear rate in air.

4. Significance and Use

4.1 Pitch does not go through a solid-liquid phase change when heated, and therefore does not have a true melting point. As the temperature is raised pitch gradually softens or becomes less viscous. For this reason, the determination of the softening point must be made by an arbitrary, but closely defined, method if the test values are to be reproducible.

4.2 This test method is useful in determining the consistency of pitches as one element in establishing the uniformity of shipments or sources of supply.

5. Apparatus

5.1 A Mettler dropping point cell³ shall be used to determine pitch softening points by this test method. These commercially available instruments consist of a control unit with a digital temperature indicator, matched furnace, sample cartridges, and accessories. The control unit automatically regulates the heating rate of the furnace. The softening point is indicated on the readout, and the heating program stopped, when the sample flow triggers a photocell detector. A general view of the contents of the Mettler is shown in **Fig. 1**.

~~5.1.1 Control Unit—This unit shall provide a continuous, linear temperature increase from 25 to 250°C at a rate of 2°C/min. A digital readout shall indicate the temperature to 0.1°C throughout.~~

¹ This test method is under the jurisdiction of ASTM Committee **D02** on Petroleum Products—Products, Liquid Fuels, and Lubricants and is the direct responsibility of Subcommittee **D02.05** on Properties of Fuels, Petroleum Coke and Carbon Material.

Current edition approved May 1, 2010/June 1, 2014. Published May 2010/July 2014. Originally approved in 1972. Last previous edition approved in 2005/2010 as D3104 – 99 (2010). (2005). DOI: 10.1520/D3104-99R10.10.1520/D3104-14.

² For referenced ASTM standards, visit the ASTM website, www.astm.org, or contact ASTM Customer Service at service@astm.org. For *Annual Book of ASTM Standards* volume information, refer to the standard's Document Summary page on the ASTM website.

³ The sole source of supply of the apparatus known to the committee at this time is available from the Mettler Toledo, Inc., Balances and Instruments, 69 Princeton-Hightstown Rd., Hightstown, NJ 08520-0071. If you are aware of alternative suppliers, please provide this information to ASTM International Headquarters. Your comments will receive careful consideration at a meeting of the responsible technical committee,¹ which you may attend.

*A Summary of Changes section appears at the end of this standard

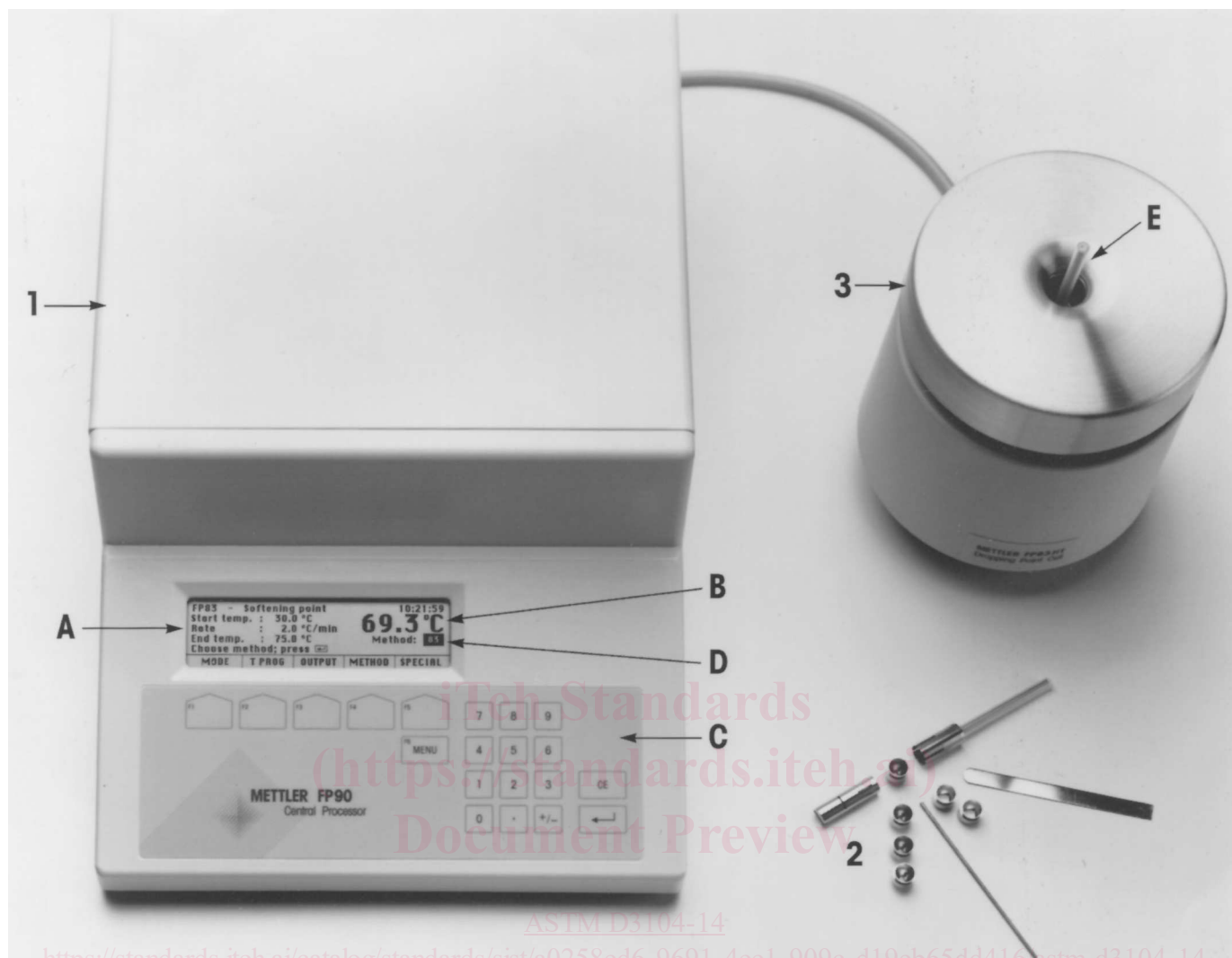

General View of the METTLER TOLEDO FP90/FP83HT

- | | |
|--|-------------------------------|
| 1 Control and evaluation unit | 2 Cartridges with accessories |
| A LCD with guide for operator | 3 Measuring cell FP83HT |
| B Temperature display | E Sample holder |
| C Keyboard with function keys F1 to F6 | |
| D Selected method number | |

FIG. 1 General View of the Mettler FP-5/53

5.1.1 *Control and Furnace Unit*—This unit shall provide a continuous, linear temperature increase from 25 to 250°C at a rate of 2°C/min. A digital readout shall indicate the temperature to 0.1°C throughout. This shall be capable of heating a one or two sample cup assembly, assemblies, as described in 5.1.35.1.2, at a linear rate of $2 \pm 0.3^\circ\text{C}/\text{min}$. It shall include a sensing system capable of detecting the softening point with a precision of 0.1°C.

5.1.2 *Sample Cup Assembly*—A cup of chromium-plated brass, or of stainless steel, or of aluminum, conforming to the requirements for Type 303 (UNS S30300) as prescribed in Specification A314, with the dimensions shown in Fig. 2. It shall be placed in the assembly so that the pitch sample will flow downward a distance of 19 mm before interrupting a light beam and stopping the heating program as the softening point is reached. softening point will be detected when it has flowed down a distance of 19 mm.

6. Reagents

6.1 Xylene, industrial grade.

6.2 Benzoic Acid.

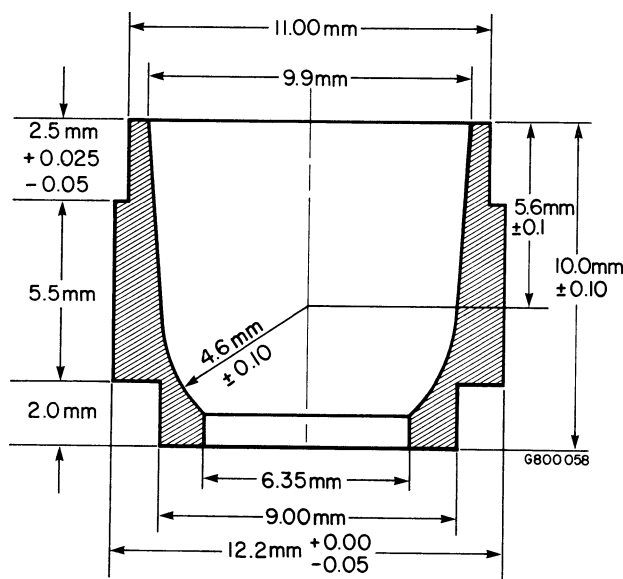

FIG. 2 Sample Cup

7. Calibration of the Mettler Apparatus

7.1 This step, required only occasionally, is designed to establish that the temperature indicated by the instrument is in agreement with a known standard. A special cup with a bottom orifice of 2.8 mm is used instead of the one prescribed for the testing of pitch.

7.2 *Reagent*—Use either analytical reagent or primary standard grade benzoic acid for the calibration. As this material is hygroscopic it must be stored in a tightly sealed container, and replaced with fresh material from a newly opened supply if hydration or other contamination is suspected.

7.3 Procedure:

7.3.1 *Filling the Sample Cup*—Place the cup on a clean, flat surface. Add a small amount of benzoic acid crystals and press down with a rod (approximately 4.5 mm in diameter). Check that the bottom orifice is completely filled. Refill and repeat the pressing step until the cup is filled with benzoic acid. Remove any crystals from the exterior of the cup.

7.3.2 *Heating*—Preheat the Mettler furnace to 121°C, and maintain it at that temperature. Place the cartridge assembly containing the benzoic acid in position in the furnace, taking care that the slits for the light beam are properly positioned. Wait for temperature equilibration, that is, the furnace and the sample are in equilibrium at the preset temperature, but not less than the 30 s after inserting the cartridge, start the automatic heating cycle at 0.2°C/min. The temperature will rise steadily at the correct rate until the drop point is reached, and then remain steady on the readout.

7.3.3 *Cleaning*—Immediately remove the cartridge assembly. Check to determine that the sample has passed through the light beam and no pre-triggering has occurred. If a malfunction is suspected, the entire procedure must be repeated. Inspect the apparatus carefully to ensure that no residue remains. Use a spatula shaped to the contour of the cup to remove most of the remaining acid from the cup and from the bottom of the cartridge. Wash the cup and cartridge in xylene, or other suitable solvent, to remove the last traces of the residue.

7.3.4 *Interpretation*—If the result is not $123.5 \pm 0.5^\circ\text{C}$, repeat the test. If the second value is 0.6° above or below 123.5°C , measure the dropping point of a fresh sample of benzoic acid. If the deviation exceeds 0.6°C , the instrument requires recalibration or repair. Consult the manufacturer's instruction manual.

NOTE 1—Users of older instruments such as FP90/83 may refer to earlier versions of this method for the sample insertion procedure for those instruments. The procedure differs in that the cup holder and receiver are different.

8. Sampling

8.1 Samples from shipments shall be taken in accordance with Practice D4296, and shall be free of foreign substances. Thoroughly mix the sample before removing a representative portion for the determination or for dehydration.

8.2 If a solid bulk sample contains free water, air-dry a representative portion in a forced draft oven at 50°C.

8.3 If the sample is liquid, check for any surface foam which may indicate the presence of water. If foam is found, maintain the sample at a temperature of about 125°C in an open container until the surface is free of foam. Take care not to overheat. Remove from the heat source as soon as the foam has subsided. Proceed as directed in 8.4.2.

8.4 *Filling the Sample Cup*: