



Designation: **D3170–12 D3170/D3170M – 14**

Standard Test Method for Chipping Resistance of Coatings¹

This standard is issued under the fixed designation ~~D3170~~; **D3170/D3170M**; the number immediately following the designation indicates the year of original adoption or, in the case of revision, the year of last revision. A number in parentheses indicates the year of last reappraisal. A superscript epsilon (ϵ) indicates an editorial change since the last revision or reappraisal.

This standard has been approved for use by agencies of the U.S. Department of Defense.

1. Scope

1.1 This test method covers the determination of the resistance of coatings to chipping damage by stones or other flying objects.

NOTE 1—This test method is similar to SAE J-400.

1.2 All dimensions are nominal unless otherwise specified.

1.3 The values stated in ~~metric units—either SI units or inch-pound units~~ are to be regarded ~~separately as the standard. The English units given in parentheses are for information only. All dimensions are nominal unless otherwise specified. Values stated in each system may not be exact equivalents; therefore, each system shall be used independently of the other. Combining values from the two systems may result in non-conformance with the standard.~~

1.4 *This standard does not purport to address all of the safety concerns, if any, associated with its use. It is the responsibility of the user of this standard to establish appropriate safety and health practices and determine the applicability of regulatory limitations prior to use.*

2. Referenced Documents

2.1 *ASTM Standards:*²

D609 Practice for Preparation of Cold-Rolled Steel Panels for Testing Paint, Varnish, Conversion Coatings, and Related Coating Products

D823 Practices for Producing Films of Uniform Thickness of Paint, Varnish, and Related Products on Test Panels

D1005 Test Method for Measurement of Dry-Film Thickness of Organic Coatings Using Micrometers

D1186 Test Methods for Nondestructive Measurement of Dry Film Thickness of Nonmagnetic Coatings Applied to a Ferrous Base (Withdrawn 2006)³

D1400 Test Method for Nondestructive Measurement of Dry Film Thickness of Nonconductive Coatings Applied to a Nonferrous Metal Base (Withdrawn 2006)³

D1733 Method for Preparation of Aluminum Alloy Panels for Testing Paint, Varnish, Lacquer, and Related Products (Withdrawn 1979)³

D2201 Practice for Preparation of Zinc-Coated and Zinc-Alloy-Coated Steel Panels for Testing Paint and Related Coating Products

2.2 *Other Documents:*

Test for Chip Resistance of Surface Coatings (J-400)⁴

3. Summary of Test Method

3.1 Standardized road gravel is projected by means of a controlled air blast at the coated specimens. All testing is conducted under controlled temperature conditions, generally either at ambient (room) temperature or at $-29 \pm 3^\circ\text{C}$ ($-20[-20 \pm 5^\circ\text{F}]$). After the gravel impact, tape is applied to remove any loose coating chips and the degree of chipping is determined.

¹ This test method is under the jurisdiction of ASTM Committee **D01** on Paint and Related Coatings, Materials, and Applications and is the direct responsibility of Subcommittee **D01.55** on Factory Applied Coatings on Preformed Products.

Current edition approved July 15, 2012; June 15, 2014. Published October 2012; July 2014. Originally approved in 1973. Last previous edition approved in 2007/2012 as D3170 – 03 (2007) – 12. DOI: 10.1520/D3170-12.10.1520/D3170_D3170M-14.

² For referenced ASTM standards, visit the ASTM website, www.astm.org, or contact ASTM Customer Service at service@astm.org. For *Annual Book of ASTM Standards* volume information, refer to the standard's Document Summary page on the ASTM website.

³ The last approved version of this historical standard is referenced on www.astm.org.

⁴ Available from Society of Automotive Engineers (SAE), 400 Commonwealth Dr., Warrendale, PA 15096-0001, <http://www.sae.org>.

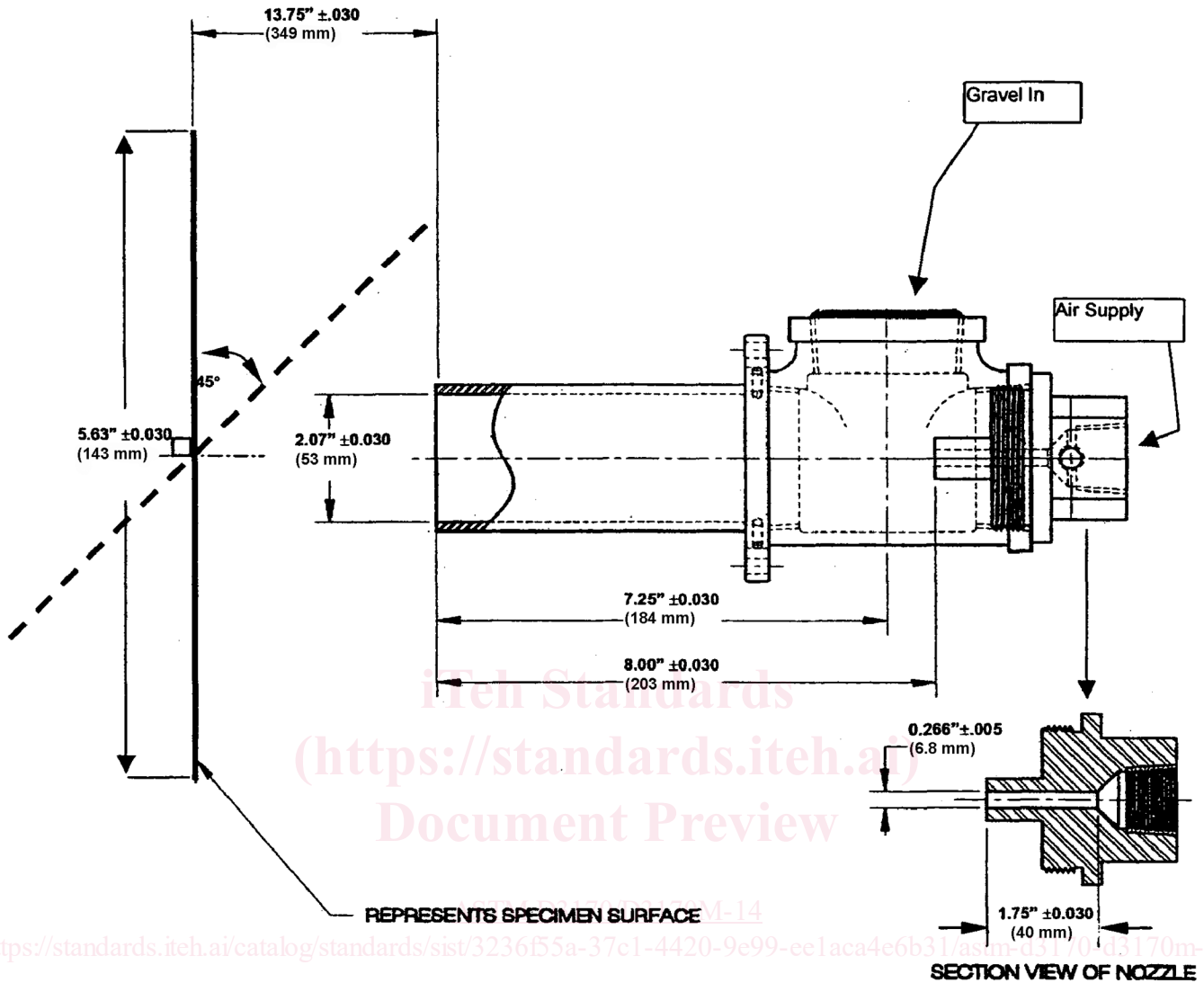

FIG. 1 Gravel Projecting Machine

4. Significance and Use

4.1 Owners consider chipping of coatings, particularly on the leading faces and edges of automobile surfaces, unacceptable. In formulating a coating or coating system to meet service requirements, the resistance to chipping damage by flying objects such as gravel is one of the properties of importance since it can vary considerably as other properties are adjusted. Since resistance to chipping decreases at lower temperatures partly as the result of decreased flexibility, the test may be more directly related to service conditions by performing it at a low temperature. This test method is designed to produce a controlled amount of impact by the media on the coated panel in order to enhance reproducibility.

5. Apparatus

5.1 *Gravel-Projecting Machine (Gravelometer)*, constructed according to the design specifications shown in Fig. 1.^{5,6} There are two types of Gravelometers: the old cabinet style and the newer, modular style with an electronic feed mechanism.

NOTE 2—It is recommended that the operation/maintenance checklist shown in Appendix X1 should be completed at least once per month for gravelometers that are operated on a weekly basis, and once every 6 months for gravelometers that are operated less frequently. Note that values in the checklist are specific to the standard gravel testing protocol. Different specifications may be necessary for other media types.

⁵ The sole source of a suitable apparatus meeting these specifications known to the committee at this time is Q-Panel Co., 26200 First St., Westlake, OH 44135.

⁶ If you are aware of alternative suppliers, please provide this information to ASTM International Headquarters. Your comments will receive careful consideration at a meeting of the responsible technical committee,¹ which you may attend.

5.2 *Gravel*—Water-eroded alluvial road gravel^{7,6} passing through a 16-mm ($\frac{5}{8}$ -in.) space screen but retained on a 9.5-mm ($\frac{3}{8}$ -in.) space screen. Note that mesh screen is not a substitute for a space screen. It is important to remove the small pieces of gravel before reusing the gravel. Other media may be used as agreed by contractual parties.

5.3 *Tape*, 100 mm (4 in.)-51 to 102 mm [2.0 to 4.0 in.] wide.^{8,6} Other tape may be used as agreed upon by the contractual parties.

5.4 *Temperature-Conditioning Equipment (alternatives):*

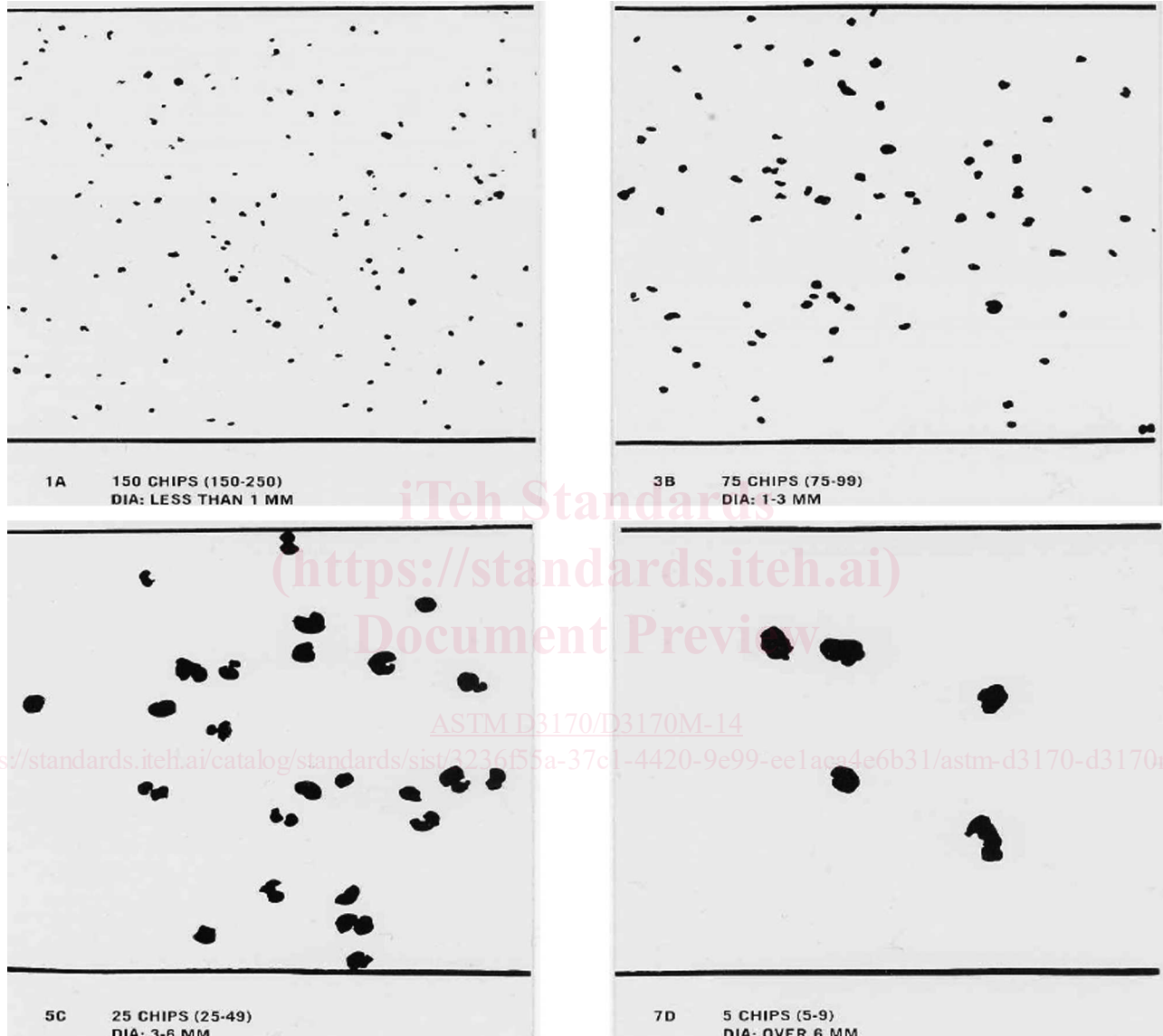

NOTE 1—Reprinted with permission from SAE EA-400 (c) 1985, Society of Automotive Engineers, Inc.

FIG. 2 Representation of Chipping Ratings

5.4.1 A cold room or freezer of sufficient size in which the gravel-projecting machine and test specimens can be maintained at the specified temperature of testing.

5.4.2 A freezer or cooler in which the test panels can be cooled 5°C (10°F) [10°F] below the specified test temperature.

5.4.3 *Ambient*—Room maintained at a temperature between 20°C (68°F) [68°F] and 30°C (86°F) [86°F].

5.5 *Transparent Grid*—A chip counting aid constructed of transparent plastic approximately 3.1763.2 mm thick by 12.7 cm [127 mm] square ($\frac{1}{8}$ by 5 by 5 in.) in., on which a 10.16 cm by 10.16 cm (4.102 by 102 mm [4 by 4 in.]) grid of 2.54 cm (1 in.) [25.4 mm] [1 in.] squares has been etched or scribed.

⁷ The sole source of supply of gravel meeting these specifications known to the committee at this time is Q-Panel Co., 26200 First St., Westlake, OH 44135.

⁸ The sole source of supply of No. 898 filament strapping tape known to the committee at this time is the 3M Co., St. Paul MN 55101.



5.6 *Chipping Rating Standards*—A photographic transparency^{9,6} depicting size and number of chips in each category. See Fig. 2 for an example of the transparencies. These standards depict various degrees of chipping severity and are arranged sequentially from best to worst according to chipping frequency.

6. Test Specimens

6.1 The composition, surface preparation, and size of specimens shall be agreed upon between the purchaser and the seller. Test panels of 102 by 305 mm (~~4~~4 by 12 ~~in.~~in.) are commonly used.

NOTE 3—It is recommended that three replicates of each test specimen be exposed in the gravelometer. More replicates will improve the accuracy.

6.2 The number, type, method of application, and aging of coatings shall be agreed upon between the purchaser and the seller.

iTeh Standards (<https://standards.iteh.ai>) Document Preview

[ASTM D3170/D3170M-14](#)

<https://standards.iteh.ai/catalog/standards/sist/3236f55a-37c1-4420-9e99-ee1aca4e6b31/astm-d3170-d3170m-14>

⁹ The sole source of supply of *Chipping Rating Standards*, Part #AE-400, known to the committee at this time is the Society of Automotive Engineers, 400 Commonwealth Dr., Warrendale, PA 15096.