International Standard



3491

INTERNATIONAL ORGANIZATION FOR STANDARDIZATION • МЕЖДУНАРОДНАЯ ОРГАНИЗАЦИЯ ПО СТАНДАРТИЗАЦИИ • ORGANISATION INTERNATIONALE DE NORMALISATION

Wrought copper and copper alloys — Drawn square bars — All minus tolerances on width across flats and form tolerances

Cuivre et alliages de cuivre corroyés — Barres étirées de section carrée — Tolérances en moins sur surplats et tolérances de forme

First edition — 1984-12-01

standards.iteh.ai

[ISO 3491:1984](https://standards.iteh.ai/catalog/standards/sist/7d1dcee4-7fbe-4126-af04-6ed81f9cda4/iso-3491-1984)

<https://standards.iteh.ai/catalog/standards/sist/7d1dcee4-7fbe-4126-af04-6ed81f9cda4/iso-3491-1984>



UDC 669.3-422-41 : 669.124

Ref. No. ISO 3491-1984 (E)

Descriptors : copper, copper alloys, drawn products, metal bars, square bars, width across flats, dimensions, dimensional tolerances, form tolerances.

Foreword

ISO (the International Organization for Standardization) is a worldwide federation of national standards bodies (ISO member bodies). The work of preparing International Standards is normally carried out through ISO technical committees. Each member body interested in a subject for which a technical committee has been established has the right to be represented on that committee. International organizations, governmental and non-governmental, in liaison with ISO, also take part in the work.

Draft International Standards adopted by the technical committees are circulated to the member bodies for approval before their acceptance as International Standards by the ISO Council. They are approved in accordance with ISO procedures requiring at least 75 % approval by the member bodies voting.

International Standard ISO 3491 was prepared by Technical Committee ISO/TC 26, *Copper and copper alloys*.

ITEH STANDARD PREVIEW
(standards.iteh.ai)

<https://standards.iteh.ai/catalog/standards/sist/7d1dcee4-7fbe-4126-af04-6ed81f69cda4/iso-3491-1984>

Wrought copper and copper alloys — Drawn square bars — All minus tolerances on width across flats and form tolerances

1 Scope and field of application

This International Standard specifies the all minus tolerances on width across flats in the range from 3 up to and including 60 mm and the form tolerances for wrought copper and copper alloy drawn square bars.

2 Reference

ISO 1637, *Wrought copper and copper alloys — Solid products supplied in straight lengths — Mechanical properties*.*

3 Dimensions and tolerances

3.1 Widths across flats

Table 1 — Tolerances on width across flats

Values in millimetres

Width across flats		Tolerance		
>	≤	Material group I ¹⁾	Material group II ²⁾	Material group III ³⁾
≥ 3	6	-0,08	-0,12	-0,18
6	10	-0,09	-0,15	-0,22
10	18	-0,11	-0,18	-0,27
18	30	-0,13	-0,21	-0,33
30	50	-0,25	-0,39	-0,62
50	60	-0,30	-0,46	-0,74

- 1) Tolerances up to and including 30 mm : h11;
over 30 up to and including 60 mm : h12;
- 2) Tolerances up to and including 30 mm : h12;
over 30 up to and including 60 mm : h13;
- 3) Tolerances up to and including 30 mm : h13
over 30 up to and including 60 mm : h14.

All tolerances rounded off to 2 decimals.

3.2 Corner radii

Square bars may have rounded corners with corner radii according to table 2.

Table 2 — Corner radii

Width across flats		Maximum corner radius
>	≤	
≥ 3	6	0,5
6	10	0,8
10	18	1,2
18	30	1,8
30	50	2,8
50	60	4,0

3.3 Twist tolerance

The twist tolerance for square bars with widths across flats in the range from 18 up to and including 60 mm is 3° per metre and 5° per total length, for the nominal lengths up to 3 000 mm; over 3 000 mm nominal length, the tolerance shall be agreed.

3.4 Straightness tolerances

3.4.1 Straightness tolerances apply for drawn bars with width across flats equal to or greater than 10 mm for all tempers, except the annealed.

Straightness tolerances for copper and copper alloy bars, except freemachining materials are given in table 3.

Table 3 — Straightness tolerances (excluding freemachining materials)

Values in millimetres

Nominal length l_{nom}		Maximum curvature (depth of arc)
>	≤	
≥ 1 000	2 000	2,0 in any length $l_m = 1 000$
2 000	3 000	5,5 in any length $l_m = 2 000$
3 000	—	12,0 in any length $l_m = 3 000$
Local kinks		0,6 in any length $l_m = 300$

* Under revision.

Straightness tolerances for freemachining materials (listed in table 7, Material group I) are given in table 4.

Table 4 – Straightness tolerances for freemachining materials

Values in millimetres

Nominal length l_{nom}		Maximum curvature (depth of arc)
>	<	
< 1 000	2 000	2,0 in any length $l_m = 1\ 000$
2 000	3 000	4,5 in any length $l_m = 2\ 000$
3 000	—	10,0 in any length $l_m = 3\ 000$
Local kinks		0,6 in any length $l_m = 300$

3.4.2 The straightness is measured by determining the curvature “c” against a straightedge, having the appropriate length l_m , when the bar is lying flat on a base plate, (see the figure).

Table 5 – Length as manufactured

Values in millimetres

Width across flats		Nominal length	Tolerance
>	<		
≥ 3	18	3 000 to 4 000	± 50
18	40		± 100
40	50	2 000 to 4 000	± 200
50	60	2 000 to 3 000	

Table 6 – Permissible underlength

Width across flats mm		Shortest permissible length as % of nominal length	Permissible mass of underlengths as % of lot mass
over	up to and including		
≥ 3	18	75	20
18	50	50	40
50	60		50

3.5 Length tolerance

3.5.1 Length as manufactured

For length as manufactured, the tolerances in table 5 apply; permissible underlengths are listed in table 6.

3.5.2 Fixed length

The length of fixed lengths shall be agreed upon between the purchaser and supplier. Fixed lengths have a tolerance of + 10₀ mm.

iTeh STANDARD PREVIEW
(standards.iteh.ai)
ISO 3491:1984
<https://standards.iteh.ai/catalog/standards/sist/7d1dccc4-7fbc-4126-af04-6ed81f69cda4/iso-3491-1984>

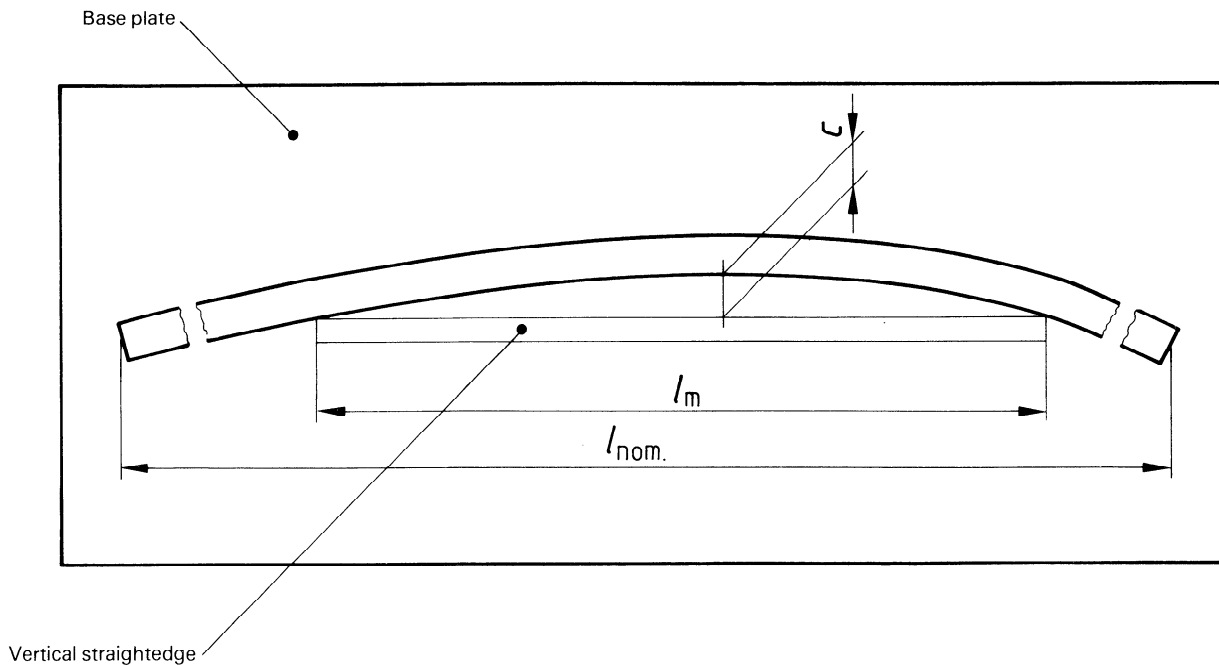

Figure – Measurement of straightness

4 Materials

Drawn square bars according to this International Standard are currently available in commercial quantities in wrought copper and copper alloys listed in table 7.

The mechanical properties of the materials listed are specified in ISO 1637.

The materials are divided into material groups I, II and III as classified in table 7.

Table 7 – Materials

Material group	Type	Designation	
I	Coppers (Cu min. 99,85 %)	Cu-ETP Cu-FRH Cu-FRTP Cu-OF Cu-HCP Cu-DLP Cu-DHP	
	Copper-zinc alloys	CuZn37 CuZn40	
	Coppers (Cu min. 97,5 %)	CuAg 0,05 CuAg 0,1 CuAg 0,05 (OF) CuAg 0,1 (OF) CuAg 0,05 (P) CuAg 0,1 (P) CuCd 1	
		CuS (P0,01) CuS (P0,03) CuTe CuTe (P)	Freemachining material
	Copper-zinc-lead alloys	CuZn34Pb2 CuZn36Pb3 CuZn40Pb CuZn39Pb1 CuZn38Pb2 CuZn40Pb2 CuZn39Pb3 CuZn38Pb4	
II	Coppers (Cu min. 97,5%)	CuCr 1 CuCr1Zr	
	Special copper-zinc alloys	CuZn37Sn1Pb1 CuZn38Sn1 CuZn39AlFeMn	
	Copper-tin alloys	CuSn5 CuSn6 CuSn8	
	Copper-nickel alloys	CuNi30Mn1Fe	
	Copper-nickel-zinc alloys	CuNi18Zn19Pb1 CuNi10Zn28Pb1	
III	Copper-aluminium alloys	CuAl7Si2 CuAl8Fe3 CuAl9Mn2 CuAl10Fe3 CuAl10Ni5Fe4	
	Special copper alloys	CuBe2 CuBe2Pb CuCo2Be CuNi2Be CuNi1Si CuNi2Si CuSi1 CuSi3Mn1	

iTeh STANDARD PREVIEW
This page intentionally left blank
(standards.iteh.ai)

[ISO 3491:1984](#)

<https://standards.iteh.ai/catalog/standards/sist/7d1dcee4-7fbe-4126-af04-6ed81f69cda4/iso-3491-1984>

iTeh STANDARD PREVIEW
This page intentionally left blank
(standards.iteh.ai)

[ISO 3491:1984](#)

<https://standards.iteh.ai/catalog/standards/sist/7d1dcee4-7fbe-4126-af04-6ed81f69cda4/iso-3491-1984>

iTeh STANDARD PREVIEW
This page intentionally left blank
(standards.iteh.ai)

[ISO 3491:1984](#)

<https://standards.iteh.ai/catalog/standards/sist/7d1dcee4-7fbe-4126-af04-6ed81f69cda4/iso-3491-1984>