



Designation: **F2052—06^{ε1} F2052 – 14**

Standard Test Method for Measurement of Magnetically Induced Displacement Force on Medical Devices in the Magnetic Resonance Environment¹

This standard is issued under the fixed designation F2052; the number immediately following the designation indicates the year of original adoption or, in the case of revision, the year of last revision. A number in parentheses indicates the year of last reappraisal. A superscript epsilon (ϵ) indicates an editorial change since the last revision or reappraisal.

^{ε1} NOTE—Paragraph X1.3 was added editorially in May 2006.

1. Scope

1.1 This test method covers the measurement of the magnetically induced displacement force produced by static magnetic field gradients on medical devices and the comparison of that force to the weight of the medical device.

1.2 This test method does not address other possible safety issues which include but are not limited to issues of magnetically induced torque, RF heating, induced heating, acoustic noise, interaction among devices, and the functionality of the device and the MR system.

1.3 This test method is intended for devices that can be suspended from a string. Devices which cannot be suspended from a string are not covered by this test method. The weight of the string from which the device is suspended during the test must be less than 1 % of the weight of the tested device.

1.4 This test method shall be carried out in a system in which the direction of the magnetically induced deflection force is ~~horizontal~~ horizontal bore MR system with a static magnetic field oriented horizontally and parallel to the MR system bore.

1.5 The values stated in SI units are to be regarded as standard. ~~Values in parentheses are for information only.~~ No other units of measurement are included in this standard.

1.6 *This standard does not purport to address all of the safety concerns, if any, associated with its use. It is the responsibility of the user of this standard to establish appropriate safety and health practices and determine the applicability of regulatory requirements prior to use.*

2. Referenced Documents

2.1 *ASTM Standards:*²

[F2119 Test Method for Evaluation of MR Image Artifacts from Passive Implants](#)

[F2182 Test Method for Measurement of Radio Frequency Induced Heating On or Near Passive Implants During Magnetic Resonance Imaging](#)

[F2213 Test Method for Measurement of Magnetically Induced Torque on Medical Devices in the Magnetic Resonance Environment](#)

[F2503 Practice for Marking Medical Devices and Other Items for Safety in the Magnetic Resonance Environment](#)

2.2 *Other Standards:*³

[IEC 60601–2–33 Ed. 2.0 Medical Electronic Equipment—Part 2: Particular Requirements for the Safety of Magnetic Resonance Equipment for Medical Diagnosis](#)

[ISO 13485:2003\(E\) Medical Devices—Quality Management Systems—Requirements for Regulatory Purposes, definition 3.7](#)

[ISO 14971 Medical devices - Application of risk management to medical devices](#)

¹ This test method is under the jurisdiction of ASTM Committee F04 on Medical and Surgical Materials and Devices and is the direct responsibility of Subcommittee F04.15 on Material Test Methods.

Current edition approved April 28, 2006 May 15, 2014. Published March 2006 August 2014. Originally approved in 2000. Last previous edition approved in 2002 2006 as F2052–02-F2052–06^{ε1}. DOI: 10.1520/F2052-06E01-10.1520/F2052-14.

² For referenced ASTM standards, visit the ASTM website, www.astm.org, or contact ASTM Customer Service at service@astm.org. For *Annual Book of ASTM Standards* volume information, refer to the standard's Document Summary page on the ASTM website.

³ Available from American National Standards Institute (ANSI), 25 W. 43rd St., 4th Floor, New York, NY 10036-10036, <http://www.ansi.org>.

3. Terminology

3.1 Definitions:

3.1.1 ~~diamagnetic material—material, n—~~a material whose relative permeability is less than unity.

3.1.2 ~~ferromagnetic material—material, n—~~a material whose magnetic moments are ordered and parallel producing magnetization in one direction.

3.1.3 ~~magnetic field strength (H in A/m) A/m , n—~~strength of the applied magnetic field.

3.1.4 ~~magnetic induction or magnetic flux density (BB in T), F_n —~~that magnetic vector quantity which at any point in a magnetic field is measured either by the mechanical force experienced by an element of electric current at the point, or by the electromotive force induced in an elementary loop during any change in flux linkages with the loop at the point. The magnetic induction is frequently referred to as the magnetic field. B_o is the static field in an MR system. Plain type indicates a scalar (for example, B) and bold type indicates a vector (for example, \mathbf{B}).

3.1.5 ~~magnetic resonance diagnostic device—device, n—~~a device intended for general diagnostic use to present images which reflect the spatial distribution or magnetic resonance spectra, or both, which reflect frequency and distribution of nuclei exhibiting nuclear magnetic resonance. Other physical parameters derived from the images or spectra, or both, may also be produced.

3.1.6 ~~magnetic resonance (MR) environment—environment, n—~~volume within the 0.50 mT (5 gauss (G)) line of an MR system, which includes the entire three dimensional volume of space surrounding the MR scanner. For cases where the 0.50 mT line is contained within the Faraday shielded volume, the entire room shall be considered the MR environment.

3.1.7 ~~magnetic resonance equipment (MR equipment)—equipment, n—~~medical electrical equipment which is intended for *in-vivo* magnetic resonance examination of a patient. The MR equipment comprises all parts in hardware and software from the supply mains to the display monitor. The MR equipment is a Programmable Electrical Medical System (PEMS).

3.1.8 ~~magnetic resonance system (MR system)—system, n—~~ensemble of MR equipment, accessories, including means for display, control, energy supplies, and the MR environment.

3.1.9 ~~magnetic resonance examination (MR examination)—examination, n—~~process of acquiring data by magnetic resonance from a patient.

3.1.10 ~~magnetic resonance (MR)—(MR), n—~~resonant absorption of electromagnetic energy by an ensemble of atomic particles situated in a magnetic field.

3.1.11 ~~medical device—device, n—~~any instrument, apparatus, implement, machine, appliance, implant, *in vitro* reagent or calibrator, software, material, or other similar or related article, intended by the manufacturer to be used, alone or in combination, for human beings for one or more of the specific purpose(s) of:

- | | |
|--|--|
| <p>(1)</p> <p>(2)</p> <p>(3)</p> <p>(4)</p> <p>(5)</p> <p>(6)</p> <p>(7)</p> | <p>diagnosis, prevention, monitoring, treatment, or alleviation of disease,</p> <p>diagnosis, monitoring, treatment, alleviation of, or compensation for an injury,</p> <p>investigation, replacement, modification, or support of the anatomy or of a physiological process,</p> <p>supporting or sustaining life,</p> <p>control of conception,</p> <p>disinfection of medical devices, and</p> <p>providing information for medical purposes by means of <i>in vitro</i> examination of specimens derived from the human body, and which does not achieve its primary intended action in or on the human body by pharmacological, immunological, or metabolic means, but which may be assisted in its function by such means.</p> |
|--|--|

IEC 60601–2–33

ISO 13485

3.1.12 ~~magnetically induced displacement force—force, n—~~force produced when a magnetic object is exposed to the spatial gradient of a magnetic field. This force will tend to cause the object to translate in the gradient field.

3.1.13 ~~paramagnetic material—material, n—~~a material having a relative permeability which is slightly greater than unity, and which is practically independent of the magnetizing force.

3.1.14 ~~tesla, (T)—(T), n—~~the SI unit of magnetic induction equal to 10^4 gauss (G).

4. Summary of Test Method

4.1 A medical device is suspended by a string ~~at the point in a magnetic field that within an MR system at a location near the entrance to the bore and on the axis of the bore. In order to increase the measurement sensitivity, this location shall be chosen so that the spatial gradient of the field strength, ∇B produce the greatest magnetically induced deflection. = dB/dz , is within 20 percent of the maximum value of the spatial gradient on the axis of the bore.~~ The angular deflection of the string from the vertical is

measured. If the device deflects less than 45°, then the magnetically induced deflection force—deflection force induced by the MR system’s magnetic field is less than the force on the device due to gravity (its weight).

NOTE 1—It is important to choose a test location on the bore axis with as large a value of ∇B as practical in order to increase the measurement sensitivity. This is particularly important if the test result is used in an analysis like that in Appendix X3 to determine a maximum allowable spatial gradient to which the device may safely be exposed.

5. Significance and Use

5.1 This test method is one of those required to determine if the presence of a medical device may cause injury to individuals during an MR examination and in the MR environment. Other safety issues which should be addressed include but may not be limited to magnetically induced torque (see Test Method F2213) and RF heating (see Test Method F2182). The terms and icons in Practice F2503 should be used to mark the device for safety in the magnetic resonance environment.

5.2 If the device deflects less than 45°, then the magnetically induced deflection force is less than the force on the device due to gravity (its weight). For this condition, it is assumed that any risk imposed by the application of the magnetically induced force is no greater than any risk imposed by normal daily activity in the Earth’s gravitational field. This statement does not constitute an acceptance criterion, however it is provided for a conservative reference point. It is possible that a greater magnetically induced deflection force can be acceptable and would not harm a patient. For forces greater than gravity the location of the implant and means of fixation must be considered. Magnetically induced deflection forces greater than the force of gravity may be acceptable when they can be justified for the specific case.

5.3 A deflection of less than 45° at the location of the maximum spatial gradient of the static magnetic field gradient in one MR system does not preclude a deflection exceeding 45° in a system with a higher field strength or larger static field spatial gradients.

5.4 This test method alone is not sufficient for determining if a device is safe in the MR environment.

6. Apparatus

6.1 The test fixture consists of a sturdy nonmagnetic structure capable of holding the test device in the proper position without deflection of the test fixture and containing a protractor with 1° graduated markings, rigidly mounted to the structure. The 0° indicator on the protractor is oriented vertically. The test device is suspended from a thin string that is attached to the 0° indicator on the protractor. In order for the weight of the string to be considered negligible when compared to the weight of the device, the weight of the string shall be less than 1 % of the weight of the device. The string shall be long enough so that the device may be suspended from the test fixture and hang freely in space. Motion of the string shall not be constrained by the support structure or the protractor. The string may be attached to the device at any convenient location.

NOTE 2—For devices with low mass, it may be appropriate to test multiple devices simultaneously in order to increase the mass of the test object.

NOTE 3—Should the device weight be small to the degree that a support weighing less than 1 % of its weight is impracticable, a scientific rationale shall be applied to the test results in order to determine whether or not the observed deflection of the device reflects a deflection force in excess of the gravitational force.

7. Test Specimens

7.1 For purposes of device qualification, the device evaluated according to this test method should be representative of manufactured medical devices that have been processed to a finished condition (for example, sterilized).

7.2 For purposes of device qualification, the devices should not be altered in any manner prior to testing.

8. Procedure

8.1 ~~Any magnet with a horizontal magnetic field that produces a large spatial gradient may be used for the test.~~ The test shall be conducted in a horizontal bore MR system with a static magnetic field oriented horizontally and parallel to the bore. Fig. 1 shows the test fixture mounted on the patient table of an MR system. The test device is suspended from a string attached to the 0° indicator on the test fixture protractor. Position the test fixture so that the center of mass of the device is at the ~~location where the deflection is a maximum~~ (see test location). The test location is at Note 1. Mark the location of the maximum deflection so

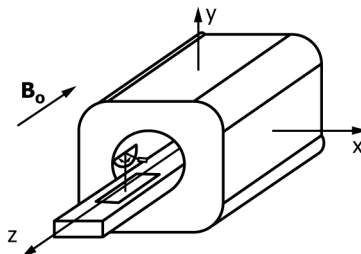

FIG. 1 Test Fixture Mounted on the Patient Table of an MRI System

all test repetitions will be conducted at the same location. Hold entrance of the MR system bore and on the axis of the bore. At the test location, the magnetically induced force, F_m , is horizontal and both B and ∇B the device act in the z direction. In order to increase the measurement sensitivity, this location shall be chosen so that the string spatial gradient of the field strength, ∇B is vertical = dB/dz , is within 20 percent of the maximum value of the spatial gradient on the axis of the bore. Record the Cartesian coordinates (x , y , z and then release it.) of the test location. Also determine and record the values of the field strength, B , and the spatial gradient of the field strength, $\nabla B = dB/dz$ at the test location. Record α , the deflection of the device from the vertical direction to the nearest 1° (see Fig. 2).

8.2 Repeat the process in 8.1 a minimum of three times for each device tested.

8.3 The device should be constrained held so that the bulk of the device is at the point of maximum deflection test location (see Appendix X2). If anything (for example, tape) is used to constrain hold the device during the test, demonstrate that the added mass does not significantly affect the measurement. The When possible, the combined weight of material used to constrain hold the device during the test shall be less than 1 % of the weight of the device. If the weight of the holding material exceeds 1 % of the weight of the device, report the weight of the holding material.

NOTE 4—In particular, nonrigid, or multi-component devices (for example, a pacemaker lead) need to be held (for example, bundled) so that the bulk of the device is at the test location.

8.4 If the device contains an electrical cord or some type of tether, arrange the device so the cord or tether has a minimal effect on the measurement. For such devices, it may be necessary to perform a series of tests to characterize the operating conditions that will produce the maximum deflection. (For instance, for an electrically powered device, tests in a number of states may be necessary to determine the operating condition that produces the maximum deflection. Possible test configurations include but are not limited to: electrical cord only, device only, device with cord attached and device turned off, device with cord attached and device activated).

NOTE 5—At the test location, the magnetically induced force, F_m , is horizontal and both B and ∇B act only in the z direction.

NOTE 6—For devices below saturation, paramagnetic materials (for example, nitinol, CoCrMo alloys, titanium and its alloys, 316L stainless steel) and for unsaturated ferromagnetic material, the magnetically induced deflection force is proportional to the product of the static magnetic field and the spatial gradient of the static magnetic field. For devices composed of these materials, the location of maximum deflection is at the point where $|B| |\nabla B|$ is a maximum. Above the magnetic saturation point, the For saturated ferromagnetic materials, the maximum deflection will occur at the location where ∇B is a maximum.

9. Calculations

9.1 Calculate the mean deflection angle using the absolute values of the values for deflection angle, α , measured in Section 8. (It is possible that instead of being attracted to the magnet, the device might be repelled by the magnet. Therefore, the absolute value of the deflection angle should be used when calculating the mean deflection angle.)

9.2 Calculate the mean magnetically induced deflection force for the device using the mean value for the deflection angle α determined in 9.1 and the following relation (derived in Appendix X2): $F_m = mg \tan \alpha$, where m is the mass of the device and g is the acceleration due to gravity. If the mean value for α is less than 45° , F_m , the magnetically induced deflection force, is less than the force on the device due to gravity (its weight).

NOTE 7—This standard does not address what the maximum acceptable magnetic induced force should be for any device. See Appendix X1 for elaboration.

10. Report

10.1 The report shall include the following for each specimen tested:

10.1.1 Device product description, including dimensioned drawing(s) or photograph(s) with dimensional scale.

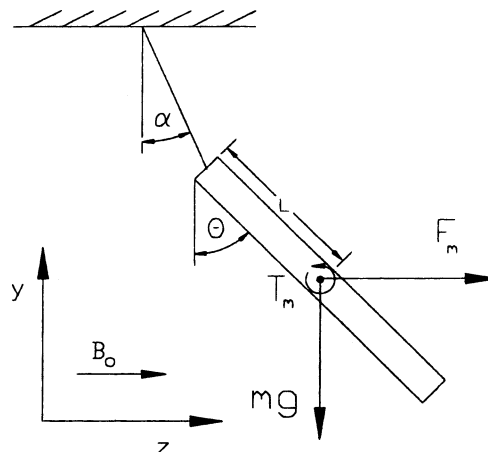

FIG. 2 Test Device in Magnetic Field

10.1.2 A diagram or photograph showing the configuration of the device during the test.

10.1.3 Device product identification (for example, batch, lot number, type number, revision, serial number, date of manufacture).

10.1.4 Materials of construction (ASTM designation or other).

10.1.5 Number of specimens tested with explanation for the sample size used.

10.1.6 Cartesian coordinate (x, y, z) location of the center of mass of the test device during the test using a right handed coordinate system with origin (0,0,0) at the isocenter of the magnet-MR system as shown in Fig. 1. Include a diagram showing the magnet-MR system and the coordinate axes. If the test magnet is an MR system, orient the coordinate system so that the y-axis is vertical and the z-axis is parallel to the patient table.

NOTE 8—For devices that deflect during the test, this location is the device position after it is released and allowed to deflect.

10.1.7 Values of $|B|$, the magnitude of the magnetic field and $|∇B|$, the magnitude of the spatial gradient of the magnetic field, at the test location.

10.1.8 Measured deflection angle, α , at the test location for each repetition of the test.

10.1.9 Mean deflection angle calculated using the absolute value of the measured values for deflection angle, α .

10.1.10 Weight of the tested device.

10.1.11 Weight of the string used to suspend the device from the test fixture.

10.1.12 Weight of material used to constrain the device during the holding material if it exceeds 1 % of the device weight (see 8.3 test).

10.1.13 Mean—For devices with a deflection angle, α greater than 45° , mean magnetically induced displacement force, F_m , calculated from measured test data for each device tested.

11. Precision and Bias

11.1 The precision and bias of this test method has not been established.

12. Keywords

12.1 medical device; metals (for surgical implants and medical devices); MRI (magnetic resonance imaging); MR safety

APPENDIXES

(Nonmandatory Information)

X1. RATIONALE FOR DEVELOPMENT OF THE TEST METHOD

<https://standards.iteh.ai/catalog/standards/sist/52de4e5e-e125-4894-b12a-f58d6b078448/astm-f2052-14>

X1.1 The primary reason for this test method is to determine the magnetically induced deflection force on medical devices that may be subjected to magnetic resonance imaging. Note that this test method only addresses the magnetically induced deflection force and that the results of this test alone are not sufficient to determine whether a particular device is safe in the MR environment. The deflection force is produced by the static magnetic field gradients, exposure of ferromagnetic, paramagnetic, and diamagnetic materials to spatially varying magnetic fields. The static field also produces a torque on a device that acts to align the object with the magnetic field (like a compass needle aligns itself with the Earth's magnetic field). For a device to be safe in the MR environment, the magnetically induced deflection force and torque should be less than forces and torques to which the device would may safely be subjected exposed if it were not in a large magnetic field, for example, a force less than the weight of the device and a torque less than that produced by normal daily activities (which might include rapidly accelerating vehicles or amusement park rides). Other possible safety issues include but are not limited to RF heating, induced heating, acoustic noise, interaction among devices, and the functionality of the device and the MR system. Although a commercial 1.5 T MR system currently produces the conditions that would most commonly be encountered by a medical device, 3 T MR systems have been cleared for market and are becoming more common in clinical situations. It is important to note that a medical device that is safe in a 1.5 T scanner may not be so in a system with higher or lower static field strength (for example, a 3 T system or a 1 T system). Also, there can be major differences in the characteristics of open and cylindrical MR systems. For instance, the static field spatial gradients may be significantly higher in open systems.

X1.1.1 After the safety of a device has been determined, it should be marked as MR Safe, MR Conditional, or MR Unsafe using the definitions and icons given in Practice F2503. The terms are defined in Practice F2503 as:

X1.1.2 MR Safe—an item that poses no known hazards in all MR environments resulting from exposure to any MR environment. MR Safe items are composed of materials that are electrically nonconductive, nonmetallic, and nonmagnetic.

NOTE X1.1—~~MR Safe items include nonconducting, nonmagnetic items such as a plastic Petri dish. An item~~ An item composed entirely of electrically nonconductive, nonmetallic and nonmagnetic materials may be determined to be MR Safe by providing a scientifically based rationale rather than test data. Examples of MR Safe items are a cotton blanket or a silicone catheter.

~~X1.1.3 MR Conditional—an item that has been demonstrated to pose no known hazards in a specified MR environment with specified conditions of use. Field conditions that define the specified MR environment include field strength, spatial gradient, with demonstrated safety in the MR environment within defined conditions. At a dB/dt minimum, (time rate of change of the magnetic field), radio frequency (RF) fields, and specific absorption rate (SAR). address the conditions of the static magnetic field, the switched gradient magnetic field and the radiofrequency fields. Additional conditions, including specific configurations of the item, may be required.~~

~~X1.1.4 MR Unsafe—an item that is known to pose hazards in all MR environments, which poses unacceptable risks to the patient, medical staff or other persons within the MR environment.~~

NOTE X1.2—ISO 14971 includes a process for evaluating risks, including identifying unacceptable risks. MR Unsafe items include ~~magnetic~~ items such as a pair of ferromagnetic scissors.

X1.2 Test Method **F2119** provides a method for evaluating image artifact for passive medical implants. Other methods may be needed to assess the image artifact from other devices.

X1.3 This test method was revised in 2005 to reference the MR safety terminology in Practice **F2503**. The historical definitions for MR safe and MR compatible were removed and the definitions of MR safe, MR conditional, and MR unsafe were inserted. Definitions for MR environment, medical device, and MR system were revised to be in agreement with the definitions in Practice **F2503**.

X1.4 This test method was revised in 2014 to require the test be performed in a MR system and change the test location to a location along the axis of the MR system bore where the static magnetic field and spatial gradient of the magnetic field have components in the z direction only. A method was added to **Appendix X3** for calculating the maximum allowable spatial gradient of the magnetic field.

ASTM F2052-14

<https://standards.iteh.ai/catalog/standards/sist/52de4e5e-e125-4894-b12a-f58d6b078448/astm-f2052-14>