



Designation: **D3514/D3514M – 10** D3514/D3514M – 10 (Reapproved 2014)

Standard Test Method for Pilling Resistance and Other Related Surface Changes of Textile Fabrics: Elastomeric Pad¹

This standard is issued under the fixed designation D3514/D3514M; the number immediately following the designation indicates the year of original adoption or, in the case of revision, the year of last revision. A number in parentheses indicates the year of last reapproval. A superscript epsilon (ϵ) indicates an editorial change since the last revision or reapproval.

1. Scope

1.1 This test method covers the determination of the resistance to the formation of pills and other surface distortions such as fuzzing of textile fabrics. The method utilizes the Stoll Quartermaster Universal Wear Tester with the frosting attachment. The procedure is generally applicable to all types of woven and knitted fabrics.

NOTE 1—For other current test methods of testing the pilling resistance of textiles, refer to Test Methods [D3511](#), [D3512](#), and [D4970](#).

1.2 The fabric may be laundered or dry cleaned before testing.

1.3 *This standard may involve hazardous materials, operations, and equipment. This standard does not purport to address all of the safety concerns, if any, associated with its use. It is the responsibility of the user of this standard to establish appropriate safety and health practices and determine the applicability of regulatory limitations prior to use.*

2. Referenced Documents

2.1 *ASTM Standards:*²

[D123 Terminology Relating to Textiles](#)

[D3511 Test Method for Pilling Resistance and Other Related Surface Changes of Textile Fabrics: Brush Pilling Tester](#)

[D3512 Test Method for Pilling Resistance and Other Related Surface Changes of Textile Fabrics: Random Tumble Pilling Tester](#)

[D4848 Terminology Related to Force, Deformation and Related Properties of Textiles](#)

[D4850 Terminology Relating to Fabrics and Fabric Test Methods](#)

[D4970 Test Method for Pilling Resistance and Other Related Surface Changes of Textile Fabrics: Martindale Tester](#)

2.2 *ASTM Adjuncts:*

[ADJD3512 Set of Photographic Standards for Random Tumble Pilling Test](#)³

[ADJD3514 Three Sets of Five Photographic Standards for Elastomeric Pad Pilling Test](#)⁴

3. Terminology

3.1 For all terminology relating to D13.59, Fabric Test Methods, General, refer to Terminology [D4850](#).

3.2 For all terminology relating to Force, Deformation and Related Properties in Textiles, refer to Terminology [D4848](#).

3.2.1 The following terms are relevant to this standard: *fuzz, pilling resistance, pills*.

3.3 For all other terminology related to textiles, refer to Terminology [D123](#).

4. Summary of Test Method

4.1 Pilling and other changes in surface appearance that occur in normal wear are simulated on a laboratory testing machine. Fabric samples are washed or drycleaned, depending on expected refurbishment, followed by controlled rubbing against an elastomeric pad having specifically selected mechanical properties. The degree of fabric pilling is evaluated by comparison of the tested specimens with visual standards that may be actual fabrics, or photographs of fabrics, showing a range of pilling resistance. The observed resistance to pilling is reported using an arbitrary rating scale.

¹ This test method is under the jurisdiction of ASTM Committee [D13](#) on Textiles and is the direct responsibility of Subcommittee [D13.60](#) on Fabric Test Methods, Specific. Current edition approved ~~June 1, 2010~~ July 1, 2014. Published ~~September 2010~~ August 2014. Originally approved in 1976. Last previous edition approved in ~~2009~~ 2010 as [D3514 – 09](#)/[D3514 – 10](#). DOI: [10.1520/D3514_D3514M-10](#)/[10.1520/D3514_D3514M-10R14](#).

² For referenced ASTM standards, visit the ASTM website, [www.astm.org](#), or contact ASTM Customer Service at [service@astm.org](#). For *Annual Book of ASTM Standards* volume information, refer to the standard's Document Summary page on the ASTM website.

³ Available from ASTM International Headquarters. Order Adjunct No. [ADJD3512](#). Original adjunct produced in 1993.

⁴ Available from ASTM International Headquarters. Order Adjunct No. [ADJD3514](#).

5. Significance and Use

5.1 *Acceptance Testing*—This method of testing fabrics for resistance to pilling is not recommended for acceptance testing. If it is used for acceptance testing, it should be used with caution because interlaboratory data are not available. In some cases the purchaser and the supplier may have to test a commercial shipment of one or more specific materials by the best available method, even though the method has not been recommended for acceptance testing.

5.1.1 If there is a disagreement arising from differences in values reported by the purchaser and the supplier when using Test Method D3514 for acceptance testing, the statistical bias, if any, between the laboratory of the purchaser and the laboratory of the supplier should be determined based on testing specimens randomly drawn from one sample of material of the type being evaluated. Competent statistical assistance is recommended for the investigation of bias. A minimum of two parties should take a group of test specimens which are as homogeneous as possible and which are from a lot of material of the type in question. The test specimens should then be randomly assigned in equal numbers to each laboratory for testing. The average test results from the two laboratories should be compared using an acceptable statistical protocol and probability level chosen by the two parties before the testing begins. Appropriate statistical disciplines for comparing data must be used when the purchaser and supplier cannot agree. If a bias is found, either its cause must be found and corrected, or the purchaser and the supplier must agree to interpret future test results with consideration for the known bias.

5.2 The pilling of textile fabrics is a very complex property because it is affected by many factors which may include type of fiber or blends, fiber dimensions, yarn and fabric construction, and fabric finishing treatments. The pilling resistance of a specific fabric in actual wear varies more with general conditions of use and individual wearers than in replicate fabric specimens subjected to controlled laboratory tests. This experience should be borne in mind when adopting levels of acceptability for any series of standards.

5.3 Finishes and fabric surface changes may exert a large effect on pilling. It is recommended that fabrics be tested after laundering or drycleaning, or both. Testing before refurbishing may also be advisable. Prior agreement between interested parties should determine the state of test.

5.4 Pills vary appreciably in size and appearance and depend on the presence of lint and degree of color contrast. These factors are not evaluated when pilling is rated solely on the number of pills. The development of pills may be accompanied by other surface phenomena such as loss of cover, color change, or the development of fuzz. Since the overall acceptability of a specific fabric is dependent on both the characteristics of the pills and the other factors affecting surface appearance, it is suggested that fabrics tested in the laboratory be evaluated subjectively with regard to their acceptability and not rated solely on the number of pills developed. A series of standards, based on graduated degrees of surface change of the fabric type being tested, may be set up to provide a basis for subjective ratings. The visual standards are most advantageous when the laboratory test specimens correlate closely in appearance with worn fabrics and show a similar ratio of pills to fuzz. Counting the pills and weighting their number with respect to their size and contrast, as a combined measure of pilling resistance, is not recommended because of the excessive time required for counting, sizing, and calculation.

5.5 The degree of fabric pilling is evaluated by comparing the tested specimens with visual standards, which may be actual fabrics or photographs of fabrics, showing a range of pilling resistance. The observed resistance to pilling is reported on an arbitrary scale ranging from 5 (no pilling) to 1 (very severe pilling).

5.6 This test method is applicable to a wide variety of woven and knitted fabrics that vary in pilling propensity as a result of variations in fiber, yarn and fabric structure, and finish. The applicability of the test method to non-woven fabrics has not been determined.

6. Apparatus and Materials

6.1 *Stoll Quartermaster Universal Wear Tester*,⁵ with frosting attachment.

6.2 *Elastomeric Friction Pad*,⁵ mounted on the bottom side of the tester pressure plate. This is a pad made especially for this test. It is attached to the pressure plate by means of side clamps, and secured at the front by a strip of tape.

6.2.1 *Elastomeric Base Pad*,⁵ attached to the specimen holder of the frosting attachment. This pad is made especially for this test.

6.3 *Twill Fabric*, cotton or polyester/cotton blend 170 to 270 g/m² [5.0 to 8.0 oz/yd²] with a moderately coarse weave.

6.4 *Emery Paper*, 150-grit, for preparation of the base pad.

6.5 *Rubber Ring*,⁵ 50 ± 1 mm [2 ± 0.1 in.] inside diameter and 61 ± 1 mm [2.44 ± 0.1 in.] outside diameter, to secure the specimen to the holder.

6.6 *Test Tube Brush*, small, to remove loose fibers from specimens after testing.

⁵ For additional information on obtaining apparatus, equipment, or supplies that may be suitable for use in this standard, please visit the ASTM Manufacturers' Equipment Directory at www.astm.org.

6.7 *Cleaning Solvent*, acetone or other appropriate solvent to clean the elastomeric pad (see 7.1).

6.8 *Facilities for Laundering Samples*—If needed.

6.9 *Facilities for Drycleaning Samples*—If needed.

6.10 *Standard In-House Pilling Test Fabric*, having an established pilling resistance rating for checking machine performance. No universal standard fabric is available. Each test facility must decide on an appropriate fabric.

6.11 *Overhead Lighting for Test Specimen Evaluation*—Two 2.4 m [8 ft] Type F-96 cool-white preheat rapid-start fluorescent lamps with white enamel reflectors, and without baffles or glass (see Fig. 1).

6.12 *Apparatus for Fabric Evaluation*—Facilities for illumination (cool white fluorescent tube) and simultaneous viewing of test specimen and fabric or photograph rating standards. Apparatus and option for visual evaluation are listed in Table 1.

6.13 *Ratings Standards*:

6.13.1 *Fabric*—A series of tested specimens of a specific fabric type which shows degree of pilling or other distortion, or both, for each type of fabric to be tested. Store the fabric rating standards and handle them under conditions that will preserve their original form and appearance. Mounting with thick cardboard framing around the specimens is recommended.

6.13.2 *Photographic*—Three sets of five photographic standards 80 mm [3.13 in.] corresponding to the size of pills produced (that is, small, medium, and large) and numbered 1 to 5 illustrating varying degrees of pilling from “very severe pilling” to “no pilling” such as ADJD3514 (ADJD3512 may also be used).

6.13.3 Digital imaging or rating system, or both.

7. Hazardous Materials

7.1 Solvents used in this test method may be hazardous. Refer to the manufacturer’s material safety data sheets for information on use, handling, storage, and disposal of these products.

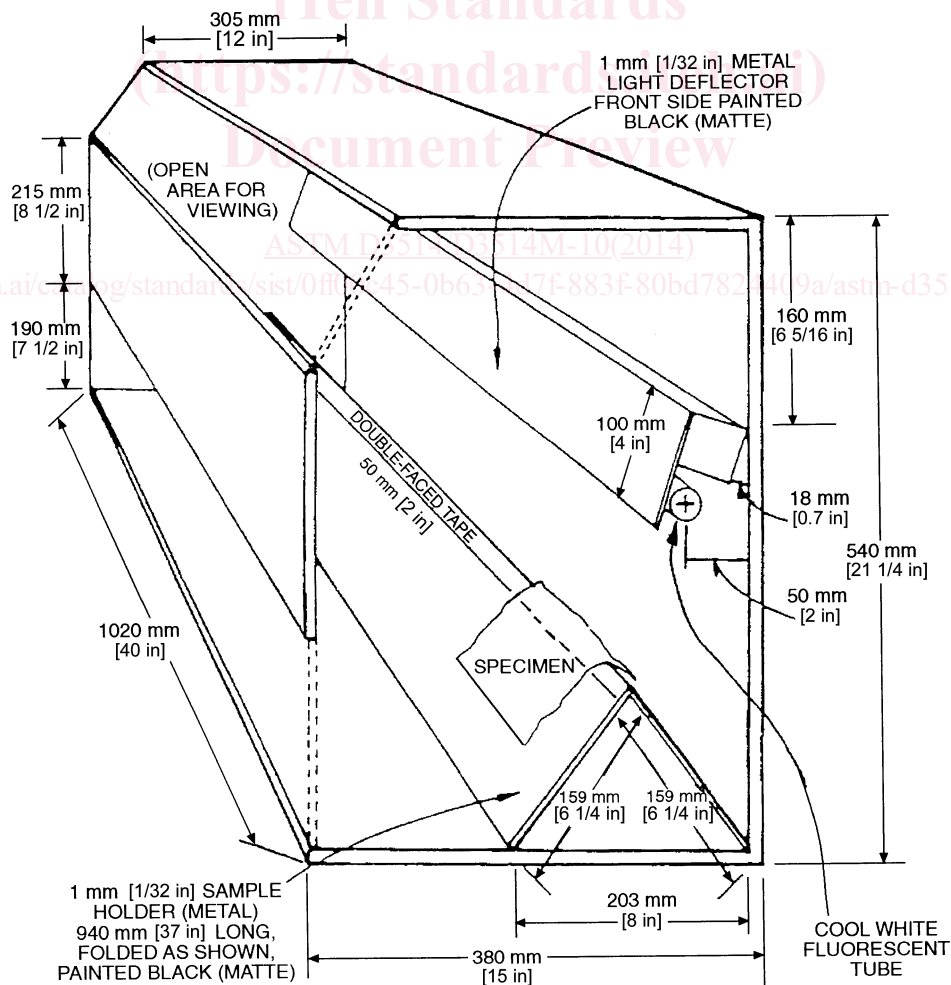

FIG. 1 Apparatus for Fabric Evaluation