



Designation: **C1610/C1610M – 10 C1610/C1610M – 14**

## Standard Test Method for Static Segregation of Self-Consolidating Concrete Using Column Technique<sup>1</sup>

This standard is issued under the fixed designation C1610/C1610M; the number immediately following the designation indicates the year of original adoption or, in the case of revision, the year of last revision. A number in parentheses indicates the year of last reapproval. A superscript epsilon ( $\epsilon$ ) indicates an editorial change since the last revision or reapproval.

### 1. Scope\*

1.1 This test method covers the determination of static segregation of self-consolidating concrete (SCC) by measuring the coarse aggregate content in the top and bottom portions of a cylindrical specimen (or column).

1.2 This test method is not applicable to self-consolidating concrete containing lightweight aggregate.

1.3 The values stated in either SI units or inch-pound units are to be regarded separately as standard. ~~Within the text, the SI units are shown in brackets.~~ The values stated in each system may not be exact equivalents; therefore, each system shall be used independently of the other. Combining values from the two systems may result in non-conformance with the standard.

1.4 The text of this standard references notes and footnotes that provide explanatory material. These notes and footnotes (excluding those in tables and figures) shall not be considered as requirements of the standard.

1.5 This test method is applicable under laboratory and field conditions.

1.6 *This standard does not purport to address all of the safety concerns, if any, associated with its use. It is the responsibility of the user of this standard to establish appropriate safety and health practices and determine the applicability of regulatory limitations prior to use. (Warning—Fresh hydraulic cementitious mixtures are caustic and may cause chemical burns to skin and tissue upon prolonged exposure.<sup>2</sup>)*

### 2. Referenced Documents

2.1 *ASTM Standards:*<sup>3</sup>

C125 Terminology Relating to Concrete and Concrete Aggregates

C127 Test Method for Density, Relative Density (Specific Gravity), and Absorption of Coarse Aggregate

C173/C173M Test Method for Air Content of Freshly Mixed Concrete by the Volumetric Method

C192/C192M Practice for Making and Curing Concrete Test Specimens in the Laboratory

C231 Test Method for Air Content of Freshly Mixed Concrete by the Pressure Method

C1712 Test Method for Rapid Assessment of Static Segregation Resistance of Self-Consolidating Concrete Using Penetration Test

D1785 Specification for Poly(Vinyl Chloride) (PVC) Plastic Pipe, Schedules 40, 80, and 120

### 3. Terminology

3.1 *Definitions:*

3.1.1 For definitions of terms used in this test method, refer to Terminology C125.

3.2 *Definitions of Terms Specific to This Standard:*

3.2.1 *Static Segregation, n*—settlement of coarse aggregate particles in an undisturbed mass of fresh concrete.

### 4. Summary of Test Method

4.1 A sample of freshly-mixed self-consolidating concrete is placed in a cylindrical mold without tamping or vibration. The mold is separated into three sections representing different levels of the cylindrical specimen (or column). Portions of concrete

<sup>1</sup> This test method is under the jurisdiction of ASTM Committee C09 on Concrete and Concrete Aggregates and is the direct responsibility of Subcommittee C09.47 on Self-Consolidating Concrete.

Current edition approved Oct. 1, 2010/April 1, 2014. Published November 2010/May 2014. Originally approved in 2006. Last previous edition approved in 2006/2010 as C1610/C1610M-06a. DOI: 10.1520/C1610-C1610M-10. DOI: 10.1520/C1610\_C1610M-14.

<sup>2</sup> Section on Safety Precautions, Manual of Aggregate and Concrete Testing, *Annual Book of ASTM Standards*, Vol. 04.02.

<sup>3</sup> For referenced ASTM standards, visit the ASTM website, www.astm.org, or contact ASTM Customer Service at service@astm.org. For *Annual Book of ASTM Standards* volume information, refer to the standard's Document Summary page on the ASTM website.

\*A Summary of Changes section appears at the end of this standard

from the top and bottom section are washed on a 4.75 mm (No. 4) sieve, leaving the coarse aggregate on the sieve. The masses of coarse aggregate in the top and the bottom sections are determined and the percent static segregation is calculated.

**5. Significance and Use**

5.1 This test method provides users with a procedure to determine the potential static segregation of self-consolidating concrete.

NOTE 1—This test method may not be sufficiently rapid to evaluate self-consolidating concrete mixtures in the field before placement. Test Method C1712 provides a rapid method for assessing static segregation resistance of self-consolidating concrete.

5.2 This test method shall be used to develop self-consolidating concrete mixtures with segregation not exceeding specified limits. Self-consolidating concrete is a fluid concrete that can be prone to segregation if not proportioned to be cohesive. A cohesive self-consolidating concrete is important for all applications but is especially critical for deep-section applications such as walls or columns. Therefore, the degree of segregation can indicate if a mixture is suitable for the application.

NOTE 2—Some level of segregation is tolerable as long as the desired strength and durability performance is achieved.

**6. Apparatus**

6.1 *Balance*—as described in Test Method C127.

6.2 *Column Mold*—The column portion of the mold shall be poly(vinyl chloride) (PVC) plastic pipe Schedule 40 meeting the requirements of Specification D1785. The column shall be 8 in. [200 mm] 200 mm [8 in.] in nominal diameter × 26 in. [660 mm] 660 mm [26 in.] in height and separated into 3 sections. The top section shall be 6.5 in. [165 mm] 165 mm [6.5 in.] in height, the middle section 13 in. [330 mm] 330 mm [13 in.] in height, and the bottom section 6.5 in. [165 mm] 165 mm [6.5 in.] in height, as shown in Fig. 1. Each section shall have its ends flat and plane and be marked as “Top”, “Middle”, or “Bottom” relative to its location in the column. Couplers, brackets, clamps, or other equivalent fastening systems shall be used for securing the column

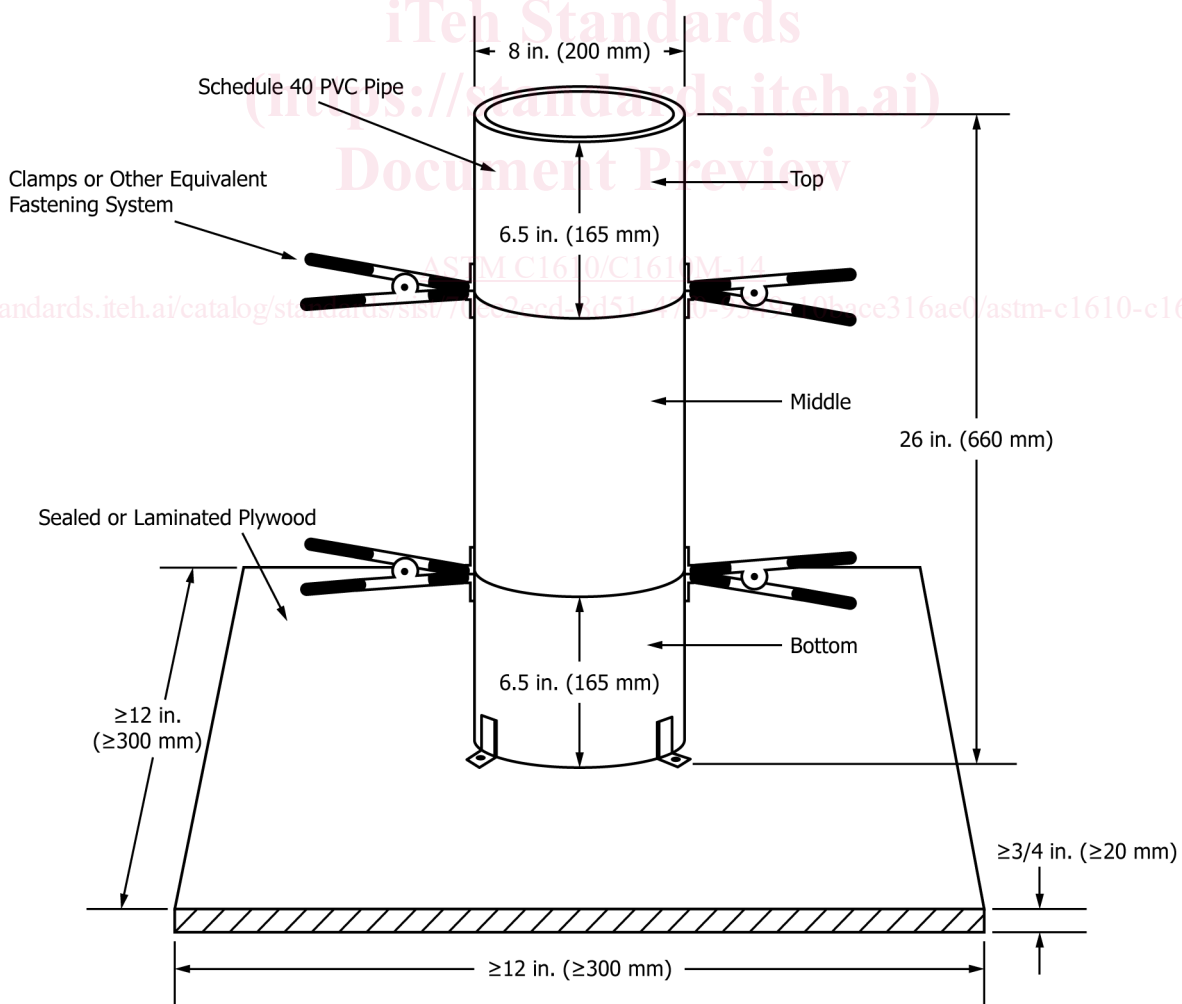

FIG. 1 Detail of Column Mold