



Designation: **C1196—09 C1196 – 14**

# Standard Test Method for In Situ Compressive Stress Within Solid Unit Masonry Estimated Using Flatjack Measurements<sup>1</sup>

This standard is issued under the fixed designation C1196; the number immediately following the designation indicates the year of original adoption or, in the case of revision, the year of last revision. A number in parentheses indicates the year of last reapproval. A superscript epsilon ( $\epsilon$ ) indicates an editorial change since the last revision or reapproval.

## 1. Scope\*

1.1 This test method covers the determination of the average compressive stress in existing unreinforced solid-unit masonry (see **Note 1**). This test method concerns the measurement of in-situ compressive stress in existing masonry by use of thin, bladder-like flatjack devices that are installed in saw-cut mortar joints in the masonry wall. This test method provides a relatively non-destructive means of determining masonry properties in place.

**NOTE 1**—Solid-unit masonry is that built with stone, concrete, or clay units whose net area is equal to or greater than 75 % of the gross area.

1.2 The values stated in inch-pound units are to be regarded as standard. The values given in parentheses are mathematical conversions to SI units that are provided for information only and are not considered standard.

1.3 *This standard does not purport to address all of the safety concerns, if any, associated with its use. It is the responsibility of the user of this standard to establish appropriate safety and health practices and determine the applicability of regulatory limitations prior to use.*

## 2. Referenced Documents

2.1 *ASTM Standards:*<sup>2</sup>

**E74 Practice of Calibration of Force-Measuring Instruments for Verifying the Force Indication of Testing Machines**

## 3. Summary of Test Method

3.1 When a slot is formed in the masonry, compressive stress at that point will cause the masonry above and below the slot to move together. Compressive stress in the masonry may be measured by inserting a flatjack into the slot and increasing its internal pressure until the original distance between points above and below the slot is restored. The state of compressive stress in the masonry is approximately equal to the flatjack pressure multiplied by factors which account for the physical characteristics of the jack and the ratio of (a) the bearing area of the jack in contact with the masonry to (b) the bearing area of the slot.<sup>6-14</sup>

## 4. Significance and Use

4.1 Stress is applied as pressure over the area of the flatjack. In the case of multi-wythe masonry, stress is estimated only in the wythe in which the flatjack is inserted. Stress in other wythes may be different.

## 5. Apparatus

5.1 *Flatjack:*

5.1.1 A flatjack is a thin envelope-like bladder with inlet and outlet ports which may be pressurized with hydraulic oil fluid. Flatjacks may be of any shape in plan, and are designed to be compatible with the masonry being tested. Typical configurations are shown in **Fig. 1**.

5.1.2 For determination of the state of compressive stress, dimension A should be equal to or greater than the length of a single masonry unit, but not less than 8 in. (200 mm). Dimension B should be equal to or greater than the thickness of one wythe and not less than 3 in. (75 mm). The radius, R, for circular and semi-rectangular flatjacks shall be equal to the radius of the circular saw blade used to cut the slot.

<sup>1</sup> This test method is under the jurisdiction of ASTM Committee C15 on Manufactured Masonry Units and is the direct responsibility of Subcommittee C15.04 on Research. Current edition approved June 1, 2009; July 1, 2014. Published July 2009; August 2014. Originally approved in 1992. Last previous edition approved in 2004 as C1196—04; C1196—09. DOI: 10.1520/C1196-09; 10.1520/C1196-14.

<sup>2</sup> For referenced ASTM standards, visit the ASTM website, www.astm.org, or contact ASTM Customer Service at service@astm.org. For *Annual Book of ASTM Standards* volume information, refer to the standard's Document Summary page on the ASTM website.

\*A Summary of Changes section appears at the end of this standard

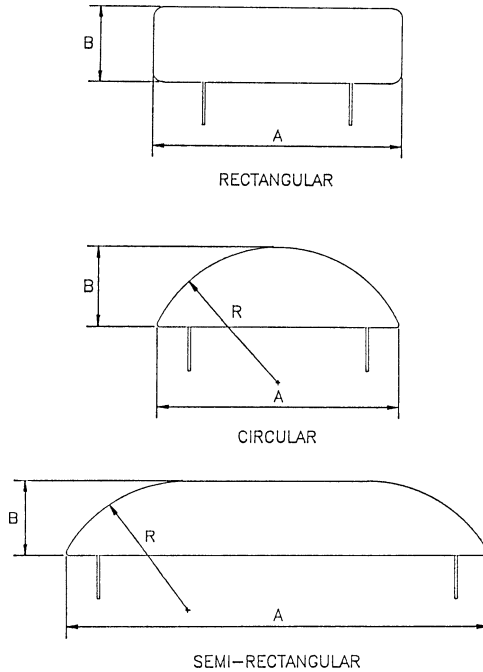

FIG. 1 Flatjack Configurations (Plan View)

5.1.3 Flatjacks shall be made of metal or other material such that the flatjack in a slot in masonry will be capable of applying operating pressures up to the expected maximum flatjack pressure. See Note 2. Metal flatjacks suitable for this purpose shall be made of type 304 stainless steel sheet of 0.024 in. (0.6 mm) to 0.048 in. (1.2 mm) ~~0.024 in. (0.6 mm) to 0.048 in. (1.2 mm)~~ in thickness with welded seams along the edges and incorporating hydraulic inlet or outlet ports.

NOTE 2—A maximum operating pressure of 1000 psi (6.9 MPa) or less is often adequate for older existing masonry, but flatjacks with higher operating pressures may be required for more recently constructed buildings. Flatjacks manufactured with flexible polymers that have operating pressure ranges of less than 1000 psi (6.9 MPa) may be useful for stress measurements in some historic masonry.

5.1.4 Calibrate all flatjacks as described in Section 7 to determine their pressure-applied load characteristics.

5.2 Hydraulic System—A hydraulic pump with hydraulic hoses is required. Hose connections shall fit the flatjack inlet port. Measure pressure using gages calibrated to a traceable standard having both an accuracy of 1 % of full hydraulic scale and an appropriate operating range. The hydraulic system shall be capable of maintaining constant pressure within 1 % of full scale for at least 5 min.

5.3 Displacement Measurement—Measure displacements of the masonry by a mechanical gage extensometer which measures the distance between fixed gage points on the masonry as shown in Fig. 2. The method or device used to measure deformations shall be capable of deformation measurements up to 3/16 in. (5 mm). Deformation measurements shall have an accuracy of at least ±0.005 % of gage length.

5.4 Gage Points—Use adhered metal discs or embedded metal inserts as gage points during the measurement process. Attach gage points securely to the masonry (using a rigid adhesive for discs or cementitious grout for plugs) which will prevent movement and ensure the required measurement accuracy. The gage points shall have a conical depression at their center, compatible with the pointed elements of the extensometer. The angles of the depression of the cone and the extensometer points shall be the same.

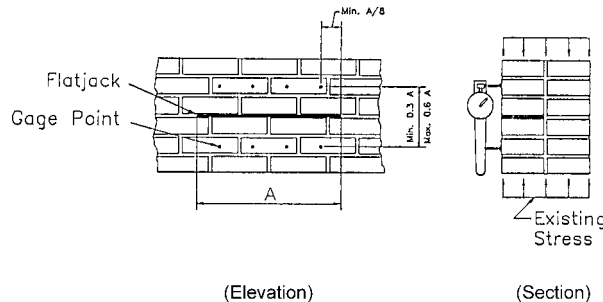

FIG. 2 Flatjack Test Setup for In Situ Stress Measurement

## 6. Preparation of Slots

6.1 Slots in masonry are normally prepared by removing the mortar from masonry bed joints to avoid disfiguring the masonry. Remove all mortar in the bed joint, so that pressure exerted by a flatjack shall be directly against the surfaces of the masonry units.

6.2 The plan geometry of the slot shall be similar to that of the flatjack being used. Plan dimensions of the prepared slot shall not exceed those of the flatjack by more than 1/2 in. (12 mm).

6.3 Slots—Prepare rectangular slots into which rectangular flatjacks are to be inserted by drilling adjacent or overlapping holes (stitch drilling) and subsequently using a drill, bar, or tool to remove mortar and produce a slot of desired dimensions with smooth upper and lower surfaces. Other tools, such as oscillating blade grinders that can be reliably used to form rectangular slots in masonry mortar joints without damaging the surrounding masonry, are also permitted to be used.

6.3.1 Rectangular slots into which rectangular flatjacks are to be inserted may be formed by drilling adjacent or overlapping holes (stitch drilling) and subsequently using a drill, bar, or tool to remove mortar and produce a slot of desired dimensions with smooth upper and lower surfaces.

6.3.2 Cut slots for circular and semi-rectangular flatjacks using circular saws of sufficient radius to provide the depth required (Fig. 1, dimension B). Use carbide or diamond tipped blades to remove all mortar from the slot.

6.4 Prepare slots for circular and semi-rectangular flatjacks using circular saws of sufficient radius to provide the depth required (Fig. 1, dimension B). Use carbide or diamond tipped blades to remove all mortar from the slot.

## 7. Calibration

7.1 A flatjack has an inherent stiffness which resists expansion when the jack is pressurized. Therefore, the fluid pressure in the flatjack is greater than the stress the flatjack applies to masonry. A flatjack must be calibrated to provide a conversion factor,  $K_m$ , to relate internal fluid pressure to stress applied.

7.2 Calibrate flatjacks in a compression machine of at least 100 kip (450 kN) capacity which has been calibrated according to Practice E74.

7.3 Place a 2 in. (50 mm) thick steel bearing plate on the lower platen of the compression machine. The bearing plate shall be of sufficient size to completely cover the flatjack being calibrated. Place the flatjack on the lower bearing plate such that the edge of the flatjack with the inlet/outlet ports is coincident with the edge of the bearing plate. Place steel spacers around the other edges of the flatjack. The thickness of the spacers shall be equal to 0.015 to approximately 0.050 in. (0.38 to 1.27 mm) greater than the sum of the combined thickness of the two sheets used in fabrication, plus the thickness of inlet/outlet port used in fabrication of the flatjack. Place the upper 2 in. (50 mm) thick bearing plate on top of the shims and flatjack, and align it to be directly above the lower bearing plate. Position the bearing plate/flatjack/shim assembly on the lower platen such that the centroid of the area of the flatjack is within 1/4 in. (6 mm) of the axis of thrust of the test machine. The calibration setup is illustrated in Fig. 3.

7.4 Raise or lower the moveable platen such that the non-moveable platen is both platens are in contact with the top-bearing plate. Apply a pre-load sufficient to provide full contact between the bearing plates and the spacers, equivalent to 10 psi (0.07 MPa) over the gross area of the flatjack.

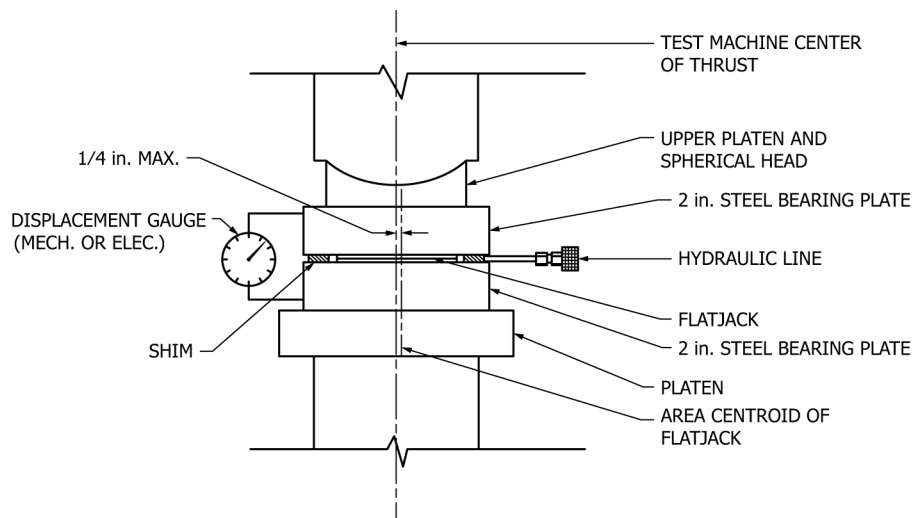

FIG. 3 Flatjack Calibration Setup (Elevation View)

7.5 The distance between platens must be held constant during the calibration procedure. Fix the displacement of the test machine at this point if using a displacement-control machine. If not, attach displacement gages (mechanical or electrical) such that the distance between platens established by the procedures of paragraph 7.4 can be held constant when using a force-control test machine.

7.6 Pressurize and depressurize the flatjack three times over the full operating pressure range. Do not exceed the maximum flatjack operating pressure.

7.6.1 While holding the distance between the platens constant, increase the pressure in the flatjack in equal increments to within 5 percent of the maximum flatjack operating pressure. Use at least 10 equal increments between 0 psi and the maximum flatjack operating pressure. At each increment, record flatjack hydraulic pressure and force applied by the test machine.

7.7 Calculate the load applied by the flatjack as internal pressure times gross flatjack area. Plot flatjack load versus load measured by the test machine with the flatjack load on the horizontal axis of the plot. The slope of the line is equal to the flatjack constant, that is, the conversion factor:

$$K_m = P_{\text{machine}} \div P_{\text{flatjack}} \tag{1}$$

7.8 Recalibrate flatjacks after using five times or when distortion appears excessive.

**8. Procedure**

8.1 The location at which compressive stress estimates are performed is dictated by engineering objectives. The basic arrangement is illustrated in Fig. 2. At the desired location or locations the following steps should be taken:

8.2 Select and mark a visible line on the masonry to define the location and length of slots to be formed.

8.3 Attach at least four pairs of equally spaced gage discs or embedded plugs vertically aligned above and below the slot as shown in Fig. 2. Each row of gage points thus formed shall be equally spaced above and below the flatjack. The minimum gage length shall be 0.3 times the length, A, where A is the length of the flatjack as shown in Fig. 1. The maximum gage length shall be 0.6 times the length, A, of the flatjack. The first and last locations shall be located not less than 1/8 of dimension A inward toward the center of the slot from each end, as shown in Fig. 2.

NOTE 3—Alternative instrumentation configurations are acceptable if controlled laboratory tests are conducted to verify the validity of the alternate instrumentation approach. Examples of alternate configurations are shown in Fig. 4. These references provide additional information about alternate instrumentation for flatjack testing.<sup>3-5</sup>

8.4 Measure the initial distance between each pair of gage points.

8.5 Prepare the slot (see Note 4) (see Section 6) and record the measured slot dimensions and the time. Clean slots of all mortar and brick particles prior to the insertion of flatjacks.

NOTE 4—The location of the slot shall be at least 1/2 flatjack lengths from wall openings or ends.

8.6 Repeat step 8.4 after the slot has been prepared to obtain the initial deviation from the original gage distances. 14

8.7 Insert the flatjack into the slot. Shim as required to achieve a tight fit and bridge over any interior voids in the masonry. See the Annex for a description of flatjack shims and their use.

8.8 Connect hydraulic hoses and fill the calibrated flatjack with hydraulic oil until pressure begins to develop.

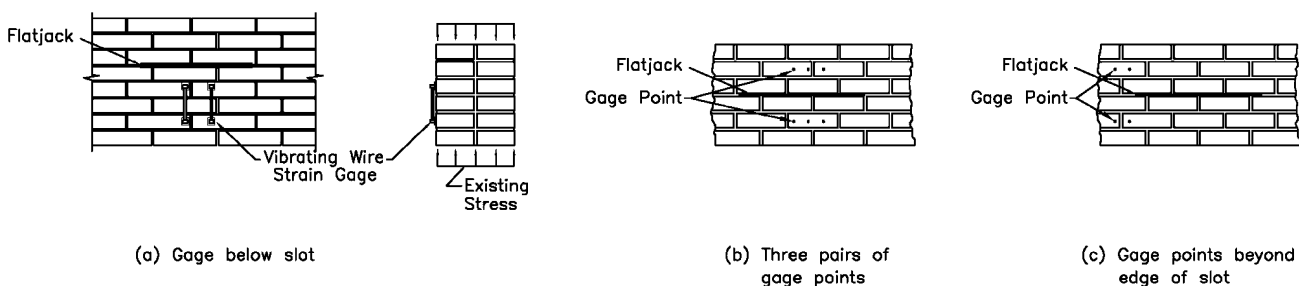

FIG. 4 Examples of Alternative Instrumentation Approaches

<sup>3</sup> Ronca, P., "The Significance of the Gauging System in the Flatjack In-Situ Stress Test for Masonry: Experimental Investigation," *The Masonry Society Journal*, Vol 14, No. 1, August 1996.

<sup>4</sup> Schuller, M., "Flatjack Methods for Diagnosis of Modern Masonry," *Proceedings, On-Site Control and Evaluation of Masonry Structures*, Binda, L., deVekey, R., editors, RILEM, 2001.

<sup>5</sup> Coombs J., Tanner J.E., "Development of Laboratories for Masonry Testing and Non-Destructive Evaluation," *The Masonry Society Journal*, Vol 26, No. 2, 2008, pp. 9-20.