



Standard Test Method for Performance of Griddles¹

This standard is issued under the fixed designation F1275; the number immediately following the designation indicates the year of original adoption or, in the case of revision, the year of last revision. A number in parentheses indicates the year of last reapproval. A superscript epsilon (ϵ) indicates an editorial change since the last revision or reapproval.

This standard has been approved for use by agencies of the U.S. Department of Defense.

1. Scope

1.1 This test method evaluates the energy consumption and cooking performance of griddles. The food service operator can use this evaluation to select a griddle and understand its energy efficiency and production capacity.

1.2 This test method is applicable to thermostatically controlled, single-source (bottom) gas and electric griddles.

1.3 The griddle can be evaluated with respect to the following (where applicable):

1.3.1 Energy input rate (10.2),

1.3.2 Temperature uniformity across the cooking surface and accuracy of the thermostats (10.3),

1.3.3 Preheat energy and time (10.4),

1.3.4 Idle energy rate (10.5),

1.3.5 Pilot energy rate (10.6),

1.3.6 Cooking energy rate and efficiency (10.7), and

1.3.7 Production capacity and cooking surface temperature recovery time (10.7).

1.4 The values stated in inch-pound units are to be regarded as standard. The values given in parentheses are mathematical conversions to SI units that are provided for information only and are not considered standard.

1.5 *This standard does not purport to address all of the safety concerns, if any, associated with its use. It is the responsibility of the user of this standard to establish appropriate safety and health practices and determine the applicability of regulatory limitations prior to use.*

2. Referenced Documents

2.1 *ASTM Standards:*²

[D3588 Practice for Calculating Heat Value, Compressibility Factor, and Relative Density of Gaseous Fuels](#)

[F1919 Specification for Griddles, Single and Double Sided, Self-heating, Counter or Stand Mounted Gas and Electric Fired](#)

2.2 *ANSI Standard:*³

[ANSI Z83.11 American National Standard for Gas Food Service Equipment](#)

2.3 *AOAC Documents:*⁴

[AOAC Official Action 950.46B Air Drying to Determine Moisture Content of Meat and Meat Products](#)

[AOAC Official Action 960.39 Fat \(Crude\) or Ether Extract in Meat](#)

2.3 *ASHRAE Document:*⁴

[ASHRAE Guideline 2-1986 \(RA90\) Engineering Analysis of Experimental Data](#)

3. Terminology

3.1 *Definitions:*

¹ This test method is under the jurisdiction of ASTM Committee F26 on Food Service Equipment and is the direct responsibility of Subcommittee F26.06 on Productivity and Energy Protocol.

Current edition approved Oct 1, 2008 April 1, 2014. Published February 2009 September 2014. Originally approved in 1990. Last previous edition approved in 2003 2008 as F1275–03 F1275 – 03 (2008). DOI: 10.1520/F1275-03R08.10.1520/F1275-14.

² For referenced ASTM standards, visit the ASTM website, www.astm.org, or contact ASTM Customer Service at service@astm.org. For *Annual Book of ASTM Standards* volume information, refer to the standard's Document Summary page on the ASTM website.

³ Available from American National Standards Institute (ANSI), 25 W. 43rd St., 4th Floor, New York, NY 10036.

⁴ Available from Association of Official Analytical Chemists, 1111 N. 19th Street, Arlington, VA 22209.

⁴ Available from American Society of Heating, Refrigerating, and Air-Conditioning Engineers, Inc. (ASHRAE), 1791 Tullie Circle, NE, Atlanta, GA 30329.

3.1.1 *cook time, n*—the time required to cook frozen hamburgers, as specified in 7.1, to a 35 ± 2 % weight loss during a cooking energy efficiency test.

3.1.2 *cooking energy, n*—energy consumed (Btu (kJ) or kWh) by the griddle as it is used to cook hamburgers under heavy- and light-load conditions.

3.1.3 *cooking energy efficiency, n*—the quantity of energy imparted to the specified food product, expressed as a percentage of energy consumed by the griddle during the cooking event.

3.1.4 *cooking energy rate, n*—the average rate of energy consumption (Btu/h (kJ/h) or kW) during the cooking energy efficiency tests. It refers to all loading scenarios (heavy and light).

3.1.5 *cooking zone, n*—the actively heated area defined of the griddle plate, from splashguard to splashguard and from splashguard to grease trough.

3.1.6 *energy input rate, n*—the peak rate (Btu/h (kJ/h) or kW) at which an appliance will consume energy, typically reflected during preheating.

3.1.7 *griddle, n*—a device for cooking food in oil or its own juices by direct contact with a hot surface.

3.1.8 *idle energy rate, n*—the average rate of energy consumed (Btu/h (kJ/h) or kW) by the griddle while “holding” or maintaining the cooking surface at the thermostat set point.

3.1.9 *pilot energy rate, n*—the average rate of energy consumption (Btu/h (kJ/h)) by a griddle’s continuous pilot (if applicable).

3.1.10 *preheat energy, n*—the amount of energy consumed (Btu (kJ) or kWh) by the griddle while preheating the cooking surface from ambient room temperature to ~~the thermostat set point.~~365°F (185°C).

3.1.11 *preheat rate, n*—the average rate (°F/min (°C/min)) at which the cooking surface temperature is heated from ambient temperature to ~~the griddle’s thermostat set point.~~365°F (185°C).

3.1.12 *preheat time, n*—the time required for the cooking surface to preheat from ambient room temperature to ~~the thermostat set point.~~365°F (185°C).

3.1.13 *production capacity, n*—the maximum rate (lb/h (kg/h)) at which the griddle can bring the specified food product to a specified “cooked” condition.

3.1.14 *production rate, n*—the average rate (lb/h (kg/h)) at which a griddle brings the specified food product to a specified “cooked” condition. It does not necessarily refer to the maximum rate. The production rate varies with the amount of food being cooked.

3.1.15 *recovery time, n*—the average time from the removal of the last hamburger patty of a load until all sections of the cooking surface are back up to within 25°F (14°C) of ~~setpoint~~temperature and are in a ready to be reloaded.cook state.

3.1.16 *test method, n*—a definitive procedure for the identification, measurement, and evaluation of one or more qualities, characteristics, or properties of a material, product, system, or service that produces a test result. <https://standards.iteh.ai/b7672/astm-f1275-14>

3.1.17 *uncertainty, n*—the measure of systematic and precision errors in specified instrumentation or the measure of repeatability of a reported test result.

4. Summary of Test Methods

4.1 The griddle ~~under test~~ is connected to the appropriate, metered energy source. The measured energy input rate is determined and checked against the rated input before continuing with any further testing.

4.2 The griddle surface temperature is monitored directly above the thermostat sensing points, and the cooking surface is calibrated to 375°F (191°C) based on these points. Additional points are monitored at predetermined locations while the griddle is idled at a nominal 375°F.

4.3 The preheat energy and time and idle energy rate are determined while the griddle is operating with the thermostats set at a calibrated 375°F (191°C). The rate of pilot energy consumption is also determined when applicable to the ~~griddle under test.~~griddle.

4.4 Energy consumption and time are monitored while the griddle is used to cook six loads of frozen, ¼-lb (0.11-kg), 20 % fat pure beef hamburger patties to a medium-done condition with the thermostats set at a calibrated 375°F (191°C). Cooking energy efficiency, cooking energy rate, production capacity, and surface temperature recovery time are determined for heavy- (whole cooking surface loaded with product) and light-load (single serving) test conditions.

5. Significance and Use

5.1 The energy input rate test is used to confirm that the griddle is operating properly prior to further testing.

5.2 The temperature uniformity of the cooking surface is used by food service operators to choose a griddle that provides a ~~uniformly cooked product.~~uniform temperature distribution.

5.3 Preheat energy and time can be useful to food service operators to manage power demands and to know how rapidly the griddle can be ready for operation.

5.4 Idle energy rate and pilot energy rate can be used to estimate energy consumption during ~~noncooking~~non-cooking periods.

5.5 Cooking energy efficiency is a precise indicator of griddle energy performance under various loading conditions. This information enables the food service operator to consider energy performance when selecting a griddle.

5.6 Production capacity is used by food service operators to choose a griddle that matches their food output requirements.

6. Apparatus

6.1 *Watt-Hour Meter*, for measuring the electrical energy consumption of a griddle, having a resolution of at least 10 Wh and a maximum uncertainty no greater than ~~1.5%~~1.0% of the measured value for any demand greater than 100 W. ~~The For any demand less than 100 W, the meter shall have a resolution of at least 101.5 Wh and a maximum uncertainty no greater than 10%~~for any demand less than 100 W: 1.5 %.

6.2 *Gas Meter*, for measuring the gas consumption of a griddle, being a positive displacement type with a resolution of at least 0.01 ft³ (0.0003 m³) and a maximum error no greater than 1 % of the measured value for any demand greater than 2.2 ft³/h (0.06 m³/h). If the meter is used for measuring the gas consumed by the pilot lights, it shall have a resolution of at least 0.01 ft³ (0.0003 m³) and have a maximum error no greater than 2 % of the measured value.

6.3 *Thermocouple(s)*, ~~24 gage,~~gauge, Type K thermocouple wire, peened flat at the exposed ends and spot welded to surfaces with a strain ~~gage~~gauge welder.

6.4 *Thermocouple Probe(s)*, industry standard Type ~~F or~~ Type-K thermocouples capable of immersion with a range from 50 to 200°F (10 to 93°C) and an uncertainty of ±1°F (0.56°C).

6.5 *Analytical Balance Scale*, for the determination of hamburger patty weight before and after cooking and for the moisture loss determination test, with a resolution of 0.01 lb (0.004 kg).

6.6 *Convection Drying Oven*, ~~with electric or indirect gas-fired convection oven with adjustable fan speed and the temperature controlled at 215 to 220°F (101 to 104°C),~~220 ± 5°F (104 ± 2.5°C), used to determine the moisture content of both the raw and cooked hamburger.

6.7 *Canopy Exhaust Hood*, 4 ft (1.2 m) in depth, wall-mounted, with the lower edge of the hood 6 ft, 6 in. (1.98 m) from the floor and with the capacity to operate at a nominal net exhaust ventilation rate of 300 cfm per linear foot (460 L/s per linear metre) of active hood length. This hood shall extend a minimum of 6 in. (152 mm) past both sides and the front of the cooking appliance and shall not incorporate side curtains or partitions. Makeup air shall be delivered through face registers or from the space, or both. Air shall not be blown in the direction of the griddle from any make up air source or from any other appliance (that is, convection oven fan).

6.8 *Barometer*, for measuring absolute atmospheric pressure, to be used for the adjustment of measured gas volume to standard conditions. It shall have a resolution of 0.2 in. Hg (670 Pa) and an uncertainty of 0.2 in. Hg.

6.9 *Data Acquisition System*, for measuring energy and temperatures, capable of multiple temperature displays updating at least every 2 s.

6.10 *Pressure ~~Gage,~~Gauge*, for monitoring gas pressure, having a range from 0 to 15 in. H₂O (0 to 3.7 kPa), resolution of 0.5 in. H₂O (125 Pa), and maximum uncertainty of 1 % of the measured value.

6.11 *Stopwatch*, with a 1-s resolution.

6.12 *Temperature Sensor*, for measuring gas temperature in the range from 50 to 100°F (10 to 38°C), with an uncertainty of ±1°F (0.56°C).

6.13 *Strain ~~Gage~~Gauge Welder*, capable of welding thermocouples to steel.⁵

7. Reagents and Materials

7.1 *Hamburger Patties*—A sufficient quantity of frozen hamburger patties shall be obtained from a meat purveyor to conduct the heavy- and light-load cooking tests. Specifications for the patties shall be four per pound, nominal 20 ± 2% fat (by weight), finished grind, pure beef patties with a moisture content between 58 and 62 % of the total hamburger weight. ~~patties.~~ The prefrozen, ¼-lb (0.11-kg) patties shall be machine-prepared to produce ~~¾-in. (9.5-mm)~~ perforated 0.475 ± 0.025-in. (9.5 ± 0.6-mm) thick patties with a ~~nominal~~minimal diameter of ~~5 in. (127 mm)~~4.75 in. (114 mm) and a maximum diameter of 5.25 in. (133 mm). For this test, beef patties should be made through press molding forming anisotropic pucks without directional grains or intentional air gaps between the grinds that may exhibit different cooking properties.

⁵ Eaton Model W1200 Strain Gauge Welder, available from Eaton Corp., 1728 Maplelawn Road, Troy, MI 48084, has been found satisfactory for this purpose.

NOTE 1—It is important to confirm by laboratory tests that the hamburger patties are within the above specifications because these specifications impact directly on cook time and energy consumption.

7.1.1 Visually inspect the patties for flatness, cupping, warpage, and dropping (excessive meat frozen to surface which causes a high spot).

7.1.2 Measure 2 % of the patties from a container for thickness, each is measured at three points around the patty (120° from each other). Use this average in setting the gap between platens (9.7).

7.1.3 Gravimetric moisture analysis shall be performed as follows: to determine moisture content, place a 1 lb sample of the test food on a dry, aluminum sheet pan and place the pan in a convection drying oven at a temperature of $220 \pm 5^{\circ}\text{F}$ for a period of 24 h. Weigh the sample before it is placed in the oven and after it is removed and determine the percent moisture content based on the percent weight loss of the sample. The sample must be thoroughly chopped ($\frac{1}{8}$ in. or smaller squares) and spread evenly over the surface of the sheet pan in order for all of the moisture to evaporate during drying and it is permissible to spread the sample on top of baking paper in order to protect the sheet pan and simplify cleanup.

NOTE 1—It is important to confirm by laboratory tests that the hamburger patties are within the above specifications because these specifications impact directly on cook time and energy consumption.

7.2 *Half-Size Sheet Pans*, measuring 18 by 13 by 1 in. (46 by 33 by 2.5 cm), for use in packaging frozen hamburger patties.

7.3 *Freezer Paper*—Waxed commercial grade, 18-in. (46-cm) wide.

7.4 *Plastic Wrap*—Commercial grade, 18-in. (46-cm) wide.

7.5 *Drip Rack*—Measuring 18 by 26 by 1 in. (46 by 66 by 2.5 cm), to hold a load of cooked hamburger patties in a single layer (that is, 24 patties for a 36 by 24-in. (91 by 61-cm) griddle).

8. Sampling and Test Units

8.1 *Griddle*—A representative production model shall be selected for performance testing.

9. Preparation of Apparatus

9.1 Install the appliance according to the manufacturer's instructions under a 4-ft (1.2-m) deep canopy exhaust hood mounted against the wall with the lower edge of the hood 78 in. (198 cm) from the floor. Position the griddle with the front edge of the cooking surface inset 6 in. (15 cm) from the front edge of the hood at the manufacturer's recommended working height. The length of the exhaust hood and active filter area shall extend a minimum of 6 in. (15 cm) past both sides of the griddle. In addition, both sides of the griddle shall be a minimum of 3 ft (0.9 m) from any side wall, side partition, or other appliance. The exhaust ventilation rate shall be 300 cfm per linear foot (460 L/s per linear metre) of hood length. (For example, a 3-ft (0.9-m) griddle shall be ventilated, at minimum, by a hood 4 by 4 ft (1.2 by 1.2 m) with a nominal air flow rate of 1200 cfm (1840 L/s). The application of a longer hood is acceptable, provided that the ventilation rate is maintained at 300 cfm per linear foot (460 L/s per linear metre) over the entire length of active hood.) Air flow rates and flow measurement procedures shall be reported. The associated heating or cooling system shall be capable of maintaining an ambient temperature of $75 \pm 5^{\circ}\text{F}$ ($24 \pm 2.8^{\circ}\text{C}$) within the testing environment when the exhaust ventilation system is working without the appliance being operated.

9.2 Connect the griddle to a calibrated energy test meter. For gas installations, a pressure regulator shall be installed downstream from the meter to maintain a constant pressure of gas for all tests. Both the pressure and temperature of the gas supplied to a griddle, as well as the barometric pressure, shall be recorded during each test so that the measured gas flow can be corrected to standard conditions. For electric installations, a voltage regulator may be required to maintain a constant nameplate voltage during all tests.

9.3 For a gas griddle, adjust (during maximum energy input) the gas supply pressure downstream from the appliance's pressure regulator to within ± 2.5 % of the operating manifold pressure specified by the manufacturer. Make adjustments to the griddle following the manufacturer's recommendations for optimizing combustion. Proper combustion may be verified by measuring air-free CO in accordance with ANSI Z83.11.

9.4 For an electric griddle, confirm (while the griddle elements are energized) that the supply voltage is within ± 2.5 % of the operating voltage specified by the manufacturer. Record the test voltage for each test.

NOTE 2—It is the intent of the test procedure herein to evaluate the performance of a griddle at its rated gas pressure or electric voltage. If an electric griddle is rated dual voltage (that is, designed to operate at either 208 or 240 V with no change in components), the voltage selected by the manufacturer or tester, or both, shall be reported. If a griddle is designed to operate at two voltages without a change in the resistance of the heating elements, the performance of the griddle (for example, the preheat time) may differ at the two voltages.

9.5 Make the griddle ready for use in accordance with the manufacturer's instructions. Temper the griddle cooking surface by following the procedures specified by the manufacturer. If not specified by the manufacturer, follow the procedures described in 9.5.1.

9.5.1 Heat the griddle surface to 375°F (191°C) as indicated by the thermostat settings. Coat the entire cooking surface with a salt-free cooking oil. Wipe off the oil residue after 5 min of heating. The griddle surface is now conditioned for testing.

10. Procedure

~~NOTE 3—Do not conduct griddle performance tests without operating the exhaust ventilation system.~~

10.1 General:

10.1.1 For gas griddles, record the following for each test run:

- (1) Higher heating value,
- (2) Standard gas pressure and temperature used to correct measured gas volume to standard conditions,
- (3) Measured gas temperature,
- (4) Measured gas pressure,
- (5) Barometric pressure,
- (6) Ambient temperature, and
- (7) Energy input rate during or immediately prior to ~~testing~~ testing while the burners are energized.

NOTE 3—Using a calorimeter or gas chromatograph in accordance with accepted laboratory procedures is the preferred method for determining the higher heating value of gas supplied to the griddle under test. It is recommended that all testing be performed with gas having a higher heating value of 1000 to 1075 Btu/ft³ (37 300 to 40 100 kJ/m³).

10.1.2 For gas griddles, add electric energy consumption to gas energy for all tests, with the exception of the energy input rate test (10.2).

10.1.3 For electric griddles, record the following for each test run:

- (1) Voltage while elements are energized,
- (2) Ambient temperature, and
- (3) Energy input rate during or immediately prior to the test ~~run~~ run while the burners are energized.

10.1.4 For each test run, confirm that the peak input rate is within $\pm 5\%$ of the rated nameplate input. Terminate testing and contact the manufacturer if the difference is greater than 5%. The manufacturer may make appropriate changes or adjustments to the griddle.

10.2 Energy Input Rate:

10.2.1 Operate the griddle with the temperature controls set to maintain an average cooking surface temperature of 375°F (191°C) directly above the thermostat temperature sensing points. The surface temperature shall be $75 \pm 5^\circ\text{F}$ ($24 \pm 2.8^\circ\text{C}$) at the start of the test. Monitor the consumption of energy for 10 min after the unit is turned on (or all burners have ignited). If the preheat time is less than 10 min (that is, the burners or elements have commenced cycling in that time), monitor the energy consumption and time after the unit is turned on until the first burner or element cycles off.

10.2.2 Confirm that the measured input rate or power (Btu/h for a gas griddle and kW for an electric griddle) is within 5% of the rated nameplate input or power. Testing shall be terminated and the manufacturer contacted if the difference is greater than 5%. The manufacturer may make appropriate changes or adjustments to the griddle or choose to supply an alternative griddle for testing. It is the intent of the test procedure herein to evaluate the performance of a griddle at its rated energy input rate.

10.3 Temperature Uniformity and Thermostat Accuracy:

10.3.1 Tack-weld K-type thermocouples to the griddle cooking surface directly above each thermostat sensing probe that is embedded in, or located below, the plate at the center of each linear foot, starting 6 in. from the left edge and finishing with a thermocouple 6 in. from the right edge. Place at least one thermocouple for every 12 in. (30 cm) of griddle length. For a 24 by 36-in. griddle, the locations are at 6, 18, and 30 in. (15, 46, and 76 cm) from the sides, centered front to back (Fig. 1).

NOTE 4—Research at Pacific Gas and Electric Co. (PG&E) indicates that thermocouples may be optimized for surface temperature measurement by flattening the thermocouple ends with locking pliers and tack-welding them to the bottom surface with a strain gage welder at the medium setting. Each end of the thermocouple is welded separately to the bottom surface $\frac{1}{8} \pm \frac{1}{16}$ in. (3.2 ± 1.6 mm) apart from the other (Fig. 1).

10.3.2 Preheat all sections of the griddle to a calibrated temperature of 375°F (191°C) as indicated by the temperature dial on the controls. Stabilize and stabilize for 60 min after the burners or elements commence cycling at the thermostat set point.

10.3.3 Monitor the surface temperature over several complete cycles of the elements or burners, where applicable. Determine the average temperature for each thermostat location.

NOTE 5—Griddles equipped with modulating thermostat controls may not exhibit cycling clearly. Monitor the thermostat bulb temperatures for a minimum of 1 h in this case.

10.3.4 Where required (as indicated by the average temperature), adjust the griddle temperature controls to attain an actual average surface temperature of $375 \pm 5^\circ\text{F}$ ($191 \pm 2.8^\circ\text{C}$). Repeat the step given in 10.3.3 to confirm that the temperature at each sensing location is $375 \pm 5^\circ\text{F}$ ($191 \pm 2.8^\circ\text{C}$).

10.3.5 To facilitate further testing, mark on the dial the exact position of the thermostat control(s) that corresponds to an average surface temperature of 375°F (191°C).

10.3.6 Additional surface temperatures shall be measured with no more than 5 in. (127 mm) between adjacent measurement points. The additional points shall be no closer to the griddle edge than 1 in. (25 mm).

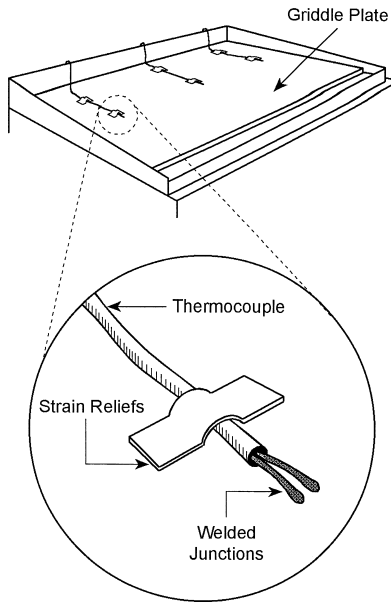

FIG. 1 Sample of Thermocouple Welding for a 3 by 2-ft (0.9 by 0.6-m) Griddle

10.3.7 Record the maximum temperature difference on the griddle surface. The maximum difference is the highest average temperature minus the lowest average temperature at any point on the cooking surface not closer than 1 in. (25 mm) from the griddle edge.

NOTE 6—The additional measurement points on the 2 by 3-ft (0.6 by 0.9-m) griddle surface can be arranged most effectively in a 6 by 8 grid. This 48-point grid is spaced evenly across the surface and provides a good representation of the surface temperatures. A sample placement of the measurement points is shown in Fig. 2.

10.4 Preheat Energy and Time:

10.4.1 Tack-weld the thermocouples to the cooking surface directly above the thermostat sensing points as in 10.3.3.1.

10.4.2 Record the cooking surface temperature and ambient kitchen temperature at the start of the test. The griddle cooking surface temperature shall be $75 \pm 5^\circ\text{F}$ ($24 \pm 2.8^\circ\text{C}$) at the start of the test.

10.4.3 Turn the griddle on with the temperature controls set to attain a surface temperature of 375°F (191°C), as determined in 10.3. Begin monitoring time and energy consumption immediately after the unit is turned on. For a gas griddle, the preheat time shall include any delay between the time the unit is turned on and the burners actually ignite.

NOTE 7—The preheat test should be conducted prior to griddle operation on the day of the test.

10.4.4 Record the surface temperature at the monitored locations (10.4.1) at a minimum of 5-s intervals during the course of entire preheat.

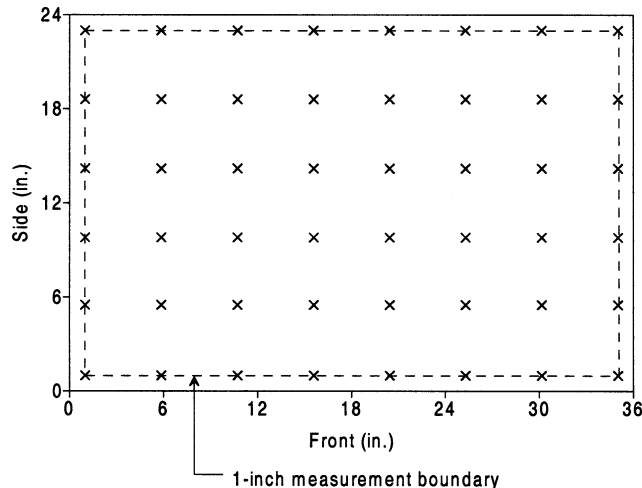

FIG. 2 Sample Placement of Thermocouples on a 3 by 2-ft (0.6 by 0.9-m) Griddle

10.4.5 Preheat is judged complete when the last of the monitored temperatures reaches 350°F (177°C). Record the energy consumption and time to preheat all sections of the griddle jointly.

10.5 *Idle Energy Rate:*

10.5.1 Allow the cooking surface temperature to stabilize at 375°F (191°C) for at least 60 min after the last thermostat has commenced cycling at the set point.

10.5.2 Monitor the energy consumption of the griddle while it is operated under this idle condition for a minimum of 2 h after the hour stabilization.

10.6 *Pilot Energy Rate (Gas Models with Standing Pilots):*

10.6.1 Where applicable, set the gas valve controlling the gas supply to the appliance at the “pilot” position. Otherwise, set the griddle temperature controls to the “off” position.

10.6.2 Light and adjust the pilots according to the manufacturer’s instructions.

10.6.3 Record the gas reading after a minimum of 8 h of pilot operation.

10.7 *Cooking Energy Efficiency and Production Capacity (Hamburger Patties):*

10.7.1 Run the cooking energy efficiency test a minimum of three times for each loading scenario. Additional test runs may be necessary to obtain the required precision for the reported test results (Annex A1).

10.7.2 ~~Verify the~~ Randomly select a minimum of six hamburger patties, each for fat and moisture content of the hamburger patties in accordance with recognized laboratory procedures (AOAC Official Action 960.39 and Official Action 950.46B). Select hamburger patties (1 for every 15) randomly, and weigh them. Record the average weight of these samples to determine the total raw weight of each load determination. Determine the fat content using a calibrated fat analyzer or other recognized laboratory procedures. Use the procedure in Annex A2 to measure the moisture content of the randomly selected patties.

10.7.3 ~~Prepare patties for~~ Weigh the necessary patties for each load and prepare them for the test by loading them onto half-size 18 by 13 by 1-in. (46 by 33 by 2.5-cm) sheet pans (Fig. 3). Package 24 patties per sheet (6 patties per level by 4 levels), separating each level by a ~~double~~ double-sided sheet of waxed freezer paper (Fig. 4). Record the total weight of the beef patties prepared for each load as the initial weight. To facilitate verification that the patties are at the required temperature for the beginning of the test, implant a thermocouple horizontally into at least one hamburger patty on a sheet pan. Cover the entire package with a commercial-grade plastic wrap. Place the sheet pans in a freezer near the griddle test area until the temperature of the patties has stabilized at the freezer temperature.

10.7.4 Monitor the temperature of the frozen patty with the thermocouple. Its internal temperature must reach $0 \pm 5^\circ\text{F}$ ($-17.8 \pm 2.8^\circ\text{C}$) before the hamburger patties can be removed from the freezer and loaded onto the griddle surface. Adjust the freezer temperature to achieve this required internal temperature (the typical freezer setting is -5°F (-21°C)) if necessary.

10.7.5 Prepare a minimum number of loads for three test runs, using the number of patties required for the loading scenario. Count on 7 to 10 loads per test run. Determine the number of patties for each loading scenario as follows:

10.7.5.1 *Heavy Loads*—A heavy load shall consist of one horizontal row of hamburger patties for every 5 in. (127 mm) of measured cooking surface depth. Each horizontal row shall consist of two patties per nominal 12 in. (305 mm) of griddle width. For example, a 3-ft (915-mm) griddle with a 24-in. deep cooking surface will require 24 patties per load, while a 3-ft (915-mm) griddle with a 30-in. deep cooking surface will require 36 patties per load for the heavy load tests.

10.7.5.2 *Light Load*—A light load shall consist of four patties positioned in the center of the cooking surface.

10.7.6 Tack-weld K-type thermocouples to the griddle cooking surface at the center of each linear foot, ~~allowing one thermocouple for every 12 in. (30 cm) of griddle length (that is, 3 for a 24 by 36-in. (61 by 91-cm) griddle).~~ starting 6 inches from the left edge and finishing with a thermocouple 6 inches from the right edge. Place at least one thermocouple for every 12 in. (30 cm) of griddle length. For a 24 by 36-in. griddle, the locations are at 6, 18, and 30 in. (15, 46, and 76 cm) from the sides, centered front to back (Fig. 1).

10.7.7 Preheat the cooking surface to 375°F (191°C). Allow the cooking surface to stabilize at the set temperature for 1 h.

10.7.8 Load the patties sequentially on the griddle cooking surface over a maximum 10-s time period for each linear foot of cooking surface (for example, 30 s for a 36-in. (76-cm) griddle and maximum 40 s for a 48-in. (122-cm) griddle).

10.7.9 Cook the patties for 3.5 min on the first side, starting from the time the first hamburger patty is placed on the cooking surface. Do not sear or press the patties during cooking.

10.7.10 Turn the patties in the same order that they were loaded over a maximum 10-s time period for each linear foot of cooking surface. Cook for an additional 2.5 min (including the time to flip hamburger patties). Do not sear or press the patties during cooking.

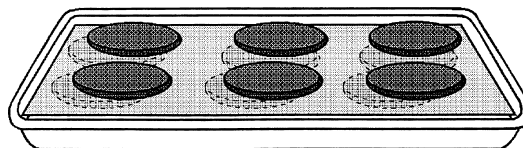

FIG. 3 Sample of Hamburger Patty Packaging

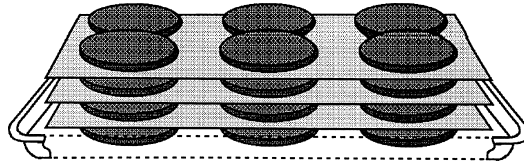

FIG. 4 Cutaway of Packaged Hamburger Patties

NOTE 8—Because mechanical searing varies from operator to operator, it is a difficult variable to specify and apply consistently. It has therefore been eliminated from the test procedure. It is recognized that this approach may establish cooking times that are in excess of the time that might be required using the same griddle in an actual food service operation. However, the objective is to determine cooking times and associated cooking energy efficiency values based on a procedure that decreases the bias from one laboratory to another. Cooking times determined for single-source (bottom) griddles using this procedure shall not be compared to cooking times for double-source (two-sided) griddles, as the “top” side inherently combines the searing (pressing) and heating process.

10.7.11 Remove the patties in the order placed on the unit over a maximum 10-s time period for each linear foot of cooking surface.

10.7.12 Hamburger patties shall be cooked to an internal temperature of 163°F (73°C) to confirm a medium-done condition. This can be accomplished by cooking the patties to a 35 % weight loss.

NOTE 9—Research conducted by PG&E has determined that the final internal temperature of cooked hamburger patties may be approximated by the percent weight loss incurred during cooking. The two are connected by a linear relationship (Fig. 5), as long as the hamburger patties are within the specifications described in 7.1.

10.7.13 Spread the patties on a drip rack using tongs. Turn the patties over after 1 min. Transfer the patties to a separate pan for weighing after an additional minute. Calculate the weight loss using the average final patty weight and the initial weight determined in 10.7.2. The percent weight loss shall be $35 \pm 2 \%$.

10.7.14 If the percent weight loss is not $35 \pm 2 \%$, repeat 10.7.8 – 10.7.13, adjusting the total cooking time to attain the $35 \pm 2 \%$ weight loss. Adjust the cooking time to attain even cooking on both sides of the patty (approximately 60 % of the total cooking time on the first side). Ensure that the griddle has recovered to 350°F (177°C) prior to reloading (all monitored points are at least 350°F (177°C)). Scrape the cooking surface during this recovery period as required and as time permits.

NOTE 10—Research at PG&E indicates that a griddle’s cooking surface has recovered sufficiently to cook another load when the surface temperature recovers to within 25°F (14°C) of the set temperature (that is, 350°F (177°C) when the thermostats are set to maintain 375°F (191°C)).

10.7.15 Cook a load of patties (10.7.8 – 10.7.13), using the cooking time determined to produce medium-done patties. After removing the patties, allow a minimum of 10 s per linear foot of cooking surface to scrape the cooking surface and prepare for reloading. Reload the griddle when all monitored points have recovered to at least 350°F (177°C).

10.7.16 Remove each patty load separately from the freezer, based on the previously determined elapsed time that is required for the patties to warm to the specified $0 \pm 5^\circ\text{F}$ ($-17.8 \pm 2.8^\circ\text{C}$) loading temperature. *Do not hand-hold the patties until loading takes place.*

10.7.17 Run as many stabilization loads as necessary to stabilize the griddle response (that is, to maintain the $35 \pm 2 \%$ weight loss). Run an additional six loads after the griddle has stabilized. Monitor the energy consumption and total test time for the final six loads. Record the percent weight loss for each load. Ensure that the average weight loss for the six-load test is $35 \pm 2 \%$.

NOTE 11—The test is invalid and must be repeated if the average weight loss for the six-load test is not $35 \pm 2 \%$.

10.7.18 Allow the cooking surface to recover to the minimum 350°F (177°C) after the last load before terminating the test. *Do not terminate the test (and energy monitoring) after removing the last patty from the last load.*

NOTE 12—The energy required to bring the griddle back up to temperature after removing the last load is considered part of the energy required by the cooking process.

10.7.19 Reserve six cooked patties (one from each load) to determine the moisture content. Place the patties in a freezer inside self-sealing plastic bags unless the moisture content test is conducted immediately.

10.7.20 Determine the moisture content of the cooked patties in accordance with ~~recognized laboratory procedures (AOAC Official Action 950.46B)~~, the procedure in Annex A2, and calculate the moisture loss based on the initial moisture content of the patties (10.7.2). Use this value in the cooking energy efficiency calculation (11.9).

10.7.21 Perform Runs 2 and 3 by repeating 10.7.15 – 10.7.20. Follow the procedure in Annex A1 to determine whether more than three test runs is required.

10.7.22 Repeat 10.7.2 – 10.7.21 for each loading scenario (see Fig. 6 and Fig. 7).

11. Calculation and Report

11.1 Test Griddle:

11.1.1 Summarize the physical and operating characteristics of the griddle. Describe other design or operating characteristics that may facilitate interpretation of the test results if needed.

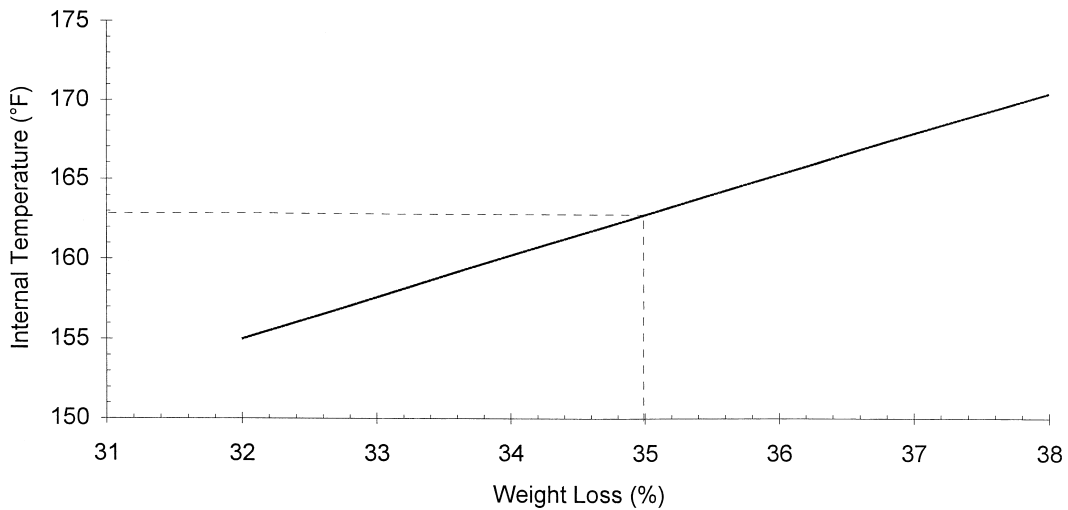
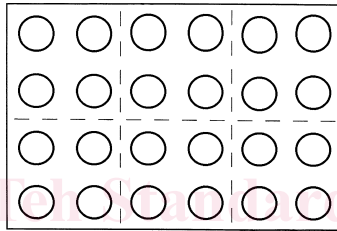

FIG. 5 Relationship Between the Bulk Internal Temperature and the Weight Loss of Cooked Hamburger Patties



All griddle sections on

FIG. 6 Patty Positions for Heavy-Load Tests on a 3 by 2-ft (0.6 by 0.9-m) Griddle Surface

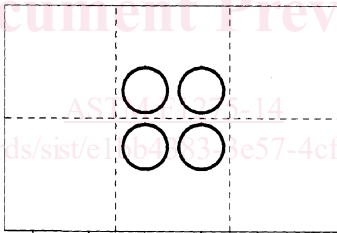

FIG. 7 Sample Placement of Hamburger Patties for Light-Load Tests on a 3 by 2-ft (0.6 by 0.9-m) Griddle Surface

11.2 Apparatus and Procedure:

11.2.1 Confirm that the testing apparatus conforms to all of the specifications stated in Section 6. Describe any deviations from those specifications.

11.2.2 For electric griddles, report the voltage for each test.

11.2.3 For gas griddles, report the higher heating value of the gas supplied to the griddle during each test.

11.3 Gas Energy Calculations:

11.3.1 For gas griddles, add the electric energy consumption to the gas energy for all tests, with the exception of the energy input rate test (10.2).

11.3.2 For all gas measurements, calculate the energy consumed based on

$$E_{gas} = V \times HV \tag{1}$$

where:

E_{gas} = energy consumed by the griddle,

HV = higher heating value,

= energy content of gas measured at standard conditions, Btu/ft³ (kJ/m³), and

V = actual volume of gas corrected for temperature and pressure at standard conditions, ft³ (m³),

= $V_{meas} \times T_{cf} \times P_{cf}$

where:

$$V_{meas} = \text{measured volume of gas, ft}^3 \text{ (m}^3\text{)},$$

$$T_{cf} = \text{temperature correction factor,}$$

$$= \frac{\text{absolute standard gas temperature } ^\circ R \text{ (} ^\circ K\text{)}}{\text{absolute actual gas temperature } ^\circ R \text{ (} ^\circ K\text{)}},$$

$$= \frac{\text{absolute standard gas temperature } ^\circ R \text{ (} ^\circ K\text{)}}{[\text{gas temp } ^\circ F \text{ (} ^\circ C\text{)} + 459.67 \text{ (273)}] ^\circ R \text{ (} ^\circ K\text{)}}, \text{ and}$$

$$P_{cf} = \text{pressure correction factor,}$$

$$= \frac{\text{absolute actual gas pressure psia (kPa)}}{\text{absolute standard pressure psia (kPa)}},$$

$$= \frac{\text{gas gage pressure psig (kPa)} + \text{barometric pressure psia (kPa)}}{\text{absolute standard pressure psia (kPa)}}$$

NOTE 13—The absolute standard gas temperature and pressure used in this calculation should be the same values used for determining the higher heating value. Standard conditions using Practice D3588 are 14.696 psia (101.33 kPa) and 60°F (519.67°R (288.71°K)).

11.4 Energy Input Rate:

11.4.1 Report the manufacturer's nameplate energy input rate in Btu/h (kJ/h) for a gas griddle and kW for an electric griddle.

11.4.2 For gas or electric griddles, calculate and report the measured energy input rate (Btu/h (kJ/h) or kW) based on the energy consumed by the griddle during the period of peak energy input according to the following relationship:

$$q_{input} = \frac{E \times 60}{t} \quad (2)$$

where:

$$q_{input} = \text{measured peak energy input rate, Btu/h (kJ/h) or kW,}$$

$$E = \text{energy consumed during the period of peak energy input, Btu (kJ) or kWh, and}$$

$$t = \text{period of peak energy input, min.}$$

11.5 Temperature Uniformity and Thermostat Accuracy:

11.5.1 Record and report discrepancies greater than 5°F (2.8°C) between the temperature indicated on the control and the measured average griddle temperature of 375°F (191°C) for each thermostat.

11.5.2 Report the average temperature at each additional temperature measurement location on a plan drawing of the griddle cooking surface. The maximum deviation between the average temperature at any measurement location on the cooking surface not closer than 1 in. (25 mm) from the edge of the cooking surface shall be noted and reported.

11.6 Preheat Energy and Time:

11.6.1 Report the preheat energy consumption (Btu (kJ) or kWh) and preheat time (min).

11.6.2 Calculate and report the average preheat rate (°F/min (°C/min)) based on the preheat period.

11.6.3 Generate a graph showing surface temperature versus time for the preheat period.

11.7 Idle Energy Rate:

11.7.1 Calculate and report the idle energy rate (Btu/h (kJ/h) or kW) based on

$$q_{idle} = \frac{E \times 60}{t} \quad (3)$$

where:

$$q_{idle} = \text{idle energy rate, Btu/h (kJ/h) or kW,}$$

$$E = \text{energy consumed during the test period, Btu (kJ) or kWh, and}$$

$$t = \text{test period, min.}$$

11.8 Pilot Energy Rate:

11.8.1 Calculate and report the pilot energy rate (Btu/h (kJ/h)) based on

$$q_{pilot} = \frac{E \times 60}{t} \quad (4)$$

where:

$$q_{pilot} = \text{pilot energy rate, Btu/h (kJ/h),}$$