



# Standard Specification for Metal Insert Fittings Utilizing a Copper Crimp Ring for SDR9 Cross-linked Polyethylene (PEX) Tubing and SDR9 Cross- linked Polyethylene/Aluminum/Cross-linked Polyethylene (PEX-AL-PEX) Tubing<sup>1</sup>

This standard is issued under the fixed designation F2434; the number immediately following the designation indicates the year of original adoption or, in the case of revision, the year of last revision. A number in parentheses indicates the year of last reapproval. A superscript epsilon ( $\epsilon$ ) indicates an editorial change since the last revision or reapproval.

## 1. Scope\*

1.1 This specification covers metal insert fittings with o-ring seals and copper crimp rings for use with Cross-linked Polyethylene (PEX) and Cross-linked Polyethylene/Aluminum/Cross-linked Polyethylene (PEX-AL-PEX) tubing in  $\frac{1}{2}$ ,  $\frac{3}{4}$ , 1, and 1  $\frac{1}{4}$  in. nominal diameters that meet the requirements for Specifications **F876** and **F2262**. These fittings are intended for use in 125 psi (861.9 kPa) (PEX-AL-PEX) and 100 psi (689.5 kPa) (PEX) cold- and hot-water distribution systems operating at temperatures up to and including 180°F (82°C). Included are the requirements for materials, workmanship, dimensions, performance, and markings to be used on the fittings and rings.

1.2 The values stated in inch-pound units are to be regarded as standard. The values given in parentheses are mathematical conversions to SI units that are provided for information only and are not considered standard.

1.3 Compliance with this specification requires that these fittings be tested and certified to Specification **F877** and **F2262**.

1.4 *This standard does not purport to address all of the safety concerns, if any, associated with its use. It is the responsibility of the user of this standard to establish appropriate safety and health practices and determine the applicability of regulatory limitations prior to use.*

## 2. Referenced Documents

### 2.1 ASTM Standards:<sup>2</sup>

**B16/B16M** Specification for Free-Cutting Brass Rod, Bar and Shapes for Use in Screw Machines

**B62** Specification for Composition Bronze or Ounce Metal Castings

**B140/B140M** Specification for Copper-Zinc-Lead (Red Brass or Hardware Bronze) Rod, Bar, and Shapes

**B283** Specification for Copper and Copper-Alloy Die Forgings (Hot-Pressed)

**B371/B371M** Specification for Copper-Zinc-Silicon Alloy Rod

**B584** Specification for Copper Alloy Sand Castings for General Applications

**D1600** Terminology for Abbreviated Terms Relating to Plastics

**D2122** Test Method for Determining Dimensions of Thermoplastic Pipe and Fittings

**E18** Test Methods for Rockwell Hardness of Metallic Materials

**F412** Terminology Relating to Plastic Piping Systems

**F876** Specification for Crosslinked Polyethylene (PEX) Tubing

**F877** Specification for Crosslinked Polyethylene (PEX) Hot- and Cold-Water Distribution Systems

**F2262** Specification for Crosslinked Polyethylene/Aluminum/Crosslinked Polyethylene Tubing OD Controlled SDR9

### 2.2 ASME Standards:<sup>3</sup>

**B1.20.1** Pipe Threads General Purpose (Inch)

**B16.18** Cast Copper Alloy Solder Joint Pressure Fittings

<sup>1</sup> This specification is under the jurisdiction of ASTM Committee **F17** on Plastic Piping Systems and is the direct responsibility of Subcommittee **F17.10** on Fittings. Current edition approved Dec. 1, 2009/Aug. 1, 2014. Published January 2010/September 2014. Originally approved in 2004. Last previous edition approved in 2008/2009 as **F2435 – 08: F2435 – 09**. DOI: 10.1520/F2434-09; 10.1520/F2434-14.

<sup>2</sup> For referenced ASTM standards, visit the ASTM website, [www.astm.org](http://www.astm.org), or contact ASTM Customer Service at [service@astm.org](mailto:service@astm.org). For *Annual Book of ASTM Standards* volume information, refer to the standard's Document Summary page on the ASTM website.

<sup>3</sup> Available from American Society of Mechanical Engineers (ASME), ASME International Headquarters, Three Park Ave., New York, NY 10016-5990, <http://www.asme.org>.

\*A Summary of Changes section appears at the end of this standard

**B16.22 Wrought Copper and Copper Alloy Solder Joint Pressure Fittings**

2.3 *Manufacturer's Standardization Society Standard:*

**SP-104 Wrought Copper Solder Joint Pressure Fittings**<sup>4</sup>

2.4 *NSF International Standards:*<sup>5</sup>

**NSF/ANSI 14 Plastic Piping Components and Related Materials**

**NSF/ANSI 61 Drinking Water System Components-Health Effects**

### 3. Terminology

3.1 Definitions are in accordance with Terminology **F412** and abbreviations are in accordance with Terminology **D1600**, unless otherwise indicated.

### 4. Classification

4.1 This specification covers one class of fittings and copper crimp rings suitable for use with tubing that meets the requirements of Specifications **F876** and **F2262**.

### 5. Materials and Manufacture

5.1 *Fittings*—The fittings shall be made from one of the following metals:

5.1.1 *Cast Copper Alloys*—Cast copper alloy fittings shall be made from material meeting the requirements of Specification **B584**, Copper Alloy UNS Nos. C84400, C83800, C87850 or C89844 or Specification **B62** Copper Alloy UNS No. C83600.

5.1.2 *Machined Brass*—Machined brass fittings shall be made from material meeting the requirements of Specification **B371/B371M**, Copper Alloy UNS No. C69300, Specification **B140/B140M** Copper Alloy UNS No. C31400, Specification **B283** Copper Alloy UNS No. C37700, or Specification **B16/B16M** Copper Alloy UNS No. C36000 or C69300 Copper Alloy UNS No. C27450.

5.1.3 *Forged Brass*—Forged brass fittings shall be made from material meeting the requirements of Specification **B283** Copper Alloy UNS Nos. C37700 or Copper Alloy UNS No. C27450.

5.2 *Crimp Rings*—Crimp rings shall be made from copper UNS Nos. C10200, or C12200, and shall be black in color, ~~color or alternately be identified per 10.2.3.2 of this specification.~~ The crimp rings shall have a minimum allowable hardness of 35 and a maximum allowable hardness of 45 on the Rockwell 15T scale when measured according to Test Methods **E18**.

5.3 *O-rings*—O-rings used on the copper alloy fittings to make a static seal shall be manufactured from ethylene propylene rubber (EPDM) or silicone rubber (Si), with a Shore A durometer between 60 and 70 when tested in accordance with Specification **D2240**.

### 6. General Requirements

6.1 The following sections of Specifications **F877** and **F2262** constitute a part of this specification.

6.1.1 Use with PEX Tubing (**F877**):

6.1.1.1 Requirements,

6.1.1.2 Test Methods, and

6.1.2 Use with PEX-AL-PEX Tubing (**F2262**):

6.1.2.1 Performance Requirements of Connectors except product marking section.

6.1.3 Retest and Rejection.

6.2 In addition, when a section with a title identical to that referenced in **6.1**, appears in this specification, it contains additional requirements that supplement those appearing in Specifications **F877** and **F2262**.

6.3 *Dimensions*—Any randomly selected fitting or fittings, and crimp ring or crimp rings, shall be used to determine dimensions. Measurements shall be made in accordance with Test Method **D2122**, except determine diameters by making measurements at four locations spaced approximately 45° apart around the circumference. Inspection and gauging of solder joint ends shall be in accordance with ASME B16.18, ASME B16.22, or MSS SP-104.

6.4 *General*—All performance tests shall be performed on assemblies of fittings, crimp rings, PEX, and PEX-AL-PEX tubing. Fittings and crimp rings shall meet the material and dimensional requirements of this specification. PEX tubing shall meet the requirements of Specification **F876**. PEX-AL-PEX tubing shall meet the requirements of Specification **F2262**. Assembly of test specimens shall be in accordance with **9.1.1**. Use separate sets of assemblies for each performance test requirement. In addition, fittings shall be designed with sufficient overall dimensions to allow proper use of crimp tool without interference with previously completed crimps on the same fitting.

<sup>4</sup> Available from Manufacturers Standardization Society of the Valve and Fittings Industry (MSS), 127 Park St., NE, Vienna, VA 22180-4602, <http://www.mss-hq.com>.

<sup>5</sup> Available from NSF International, P.O. Box 130140, 789 N. Dixboro Rd., Ann Arbor, MI 48113-0140, <http://www.nsf.org>.

7. Dimensions

7.1 *Dimensions and Tolerances*—The dimensions and tolerances of fittings and crimp rings shall be as shown in Fig. 1, Fig. 3, Fig. 4, and Table 1, when measured in accordance with 6.3.

7.1.1 *Alignment*—The maximum angular variation of any opening shall not exceed 1° off the true centerline axis.

7.1.2 *Fittings with Solder Joint Ends*—Solder joint ends shall be in accordance with ASME B16.22, ASME B16.18, or MSS SP-104.

7.1.3 *Tapered Threaded Ends*—Fitting threads shall be right-hand conforming to ASME B1.20.1. They shall be taper threads (NPT).

8. Workmanship, Finish, and Appearance

8.1 The sealing surfaces of the insert shall be smooth and free of foreign material. Fitting walls shall be free of cracks, holes, blisters, voids, foreign inclusions, or other defects that are visible to the unaided eye, that affect the wall integrity.

9. Assembly

9.1 *Crimp Joints*—Insert fittings shall be joined to PEX, or PEX-AL-PEX, tubing by the compression of a copper crimp ring around the outer circumference of the tubing, forcing the tubing material into annular spaces formed by ribs on the fitting. Insert fittings and crimp rings shall meet the dimensional and material requirements of this standard. The dimensions and out-of-roundness of the crimp ring, after it has been crimped, shall be in accordance with Table 1.

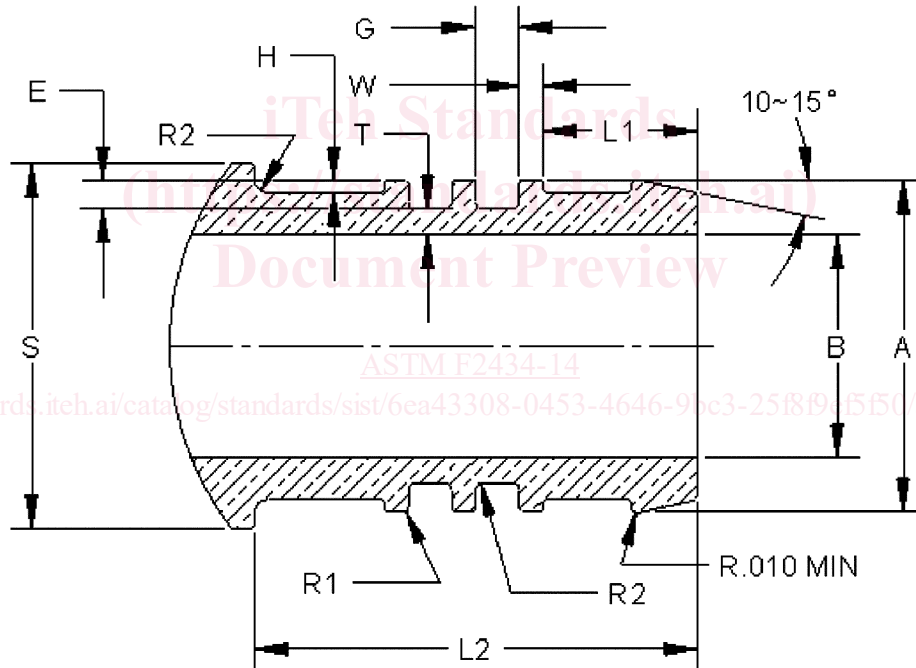

Size	A Outside Diameter of Rib	B Mini- mum ID	L1 Distance to First Rib	L2 Min Insert Length <sup>A</sup>	H Min Rib Height	Num- ber of Ribs <sup>B</sup>	W Rib <sup>C</sup> Width	G Rib Spacing Typical	T Mini- mum Wall <sup>D</sup>	R1 Mini- mum Rib Ra- dius	R2 Mini- mum Ra- dius	S Isolator Diameter <sup>E</sup>	E Groove Depth
½ in.	0.471 ± 0.004	0.310	0.214-0.224	0.625	0.013	3	0.03–0.04	0.058–0.066	0.028	0.006	0.015	0.518 ± 0.002	0.040± 0.001
¾ in.	0.667 ± 0.004	0.500	0.214-0.224	0.625	0.013	3	0.03–0.04	0.058–0.066	0.037	0.006	0.015	0.738 ± 0.005	0.040± 0.001
1 in.	0.856 ± 0.004	0.667	0.214-0.224	0.795	0.013	4	0.03–0.04	0.058–0.066	0.041	0.006	0.015	0.963 ± 0.005	0.040± 0.001
1¼ in.	1.045 ± 0.004	0.860	0.214-0.224	0.795	0.013	4	0.03–0.04	0.058–0.066	0.045	0.006	0.015	1.150 ± 0.005	0.040± 0.001

<sup>A</sup> Measured from shoulder of rib to end of fitting.

<sup>B</sup> Lead chamfer area is not considered a rib.

<sup>C</sup> Rib sides may be angled.

<sup>D</sup> Applies to entire fitting, not just insert area.

<sup>E</sup> This diameter serves as a tube stop to isolate Aluminum layer, in PEX-AL-PEX tubing, preventing contact with the brass.

FIG. 1 Fitting Insert Dimensions and Tolerances