



Designation: ~~D2854~~—~~09~~ D2854 – 09 (Reapproved 2014)

Standard Test Method for Apparent Density of Activated Carbon¹

This standard is issued under the fixed designation D2854; the number immediately following the designation indicates the year of original adoption or, in the case of revision, the year of last revision. A number in parentheses indicates the year of last reapproval. A superscript epsilon (ϵ) indicates an editorial change since the last revision or reapproval.

This standard has been approved for use by agencies of the U.S. Department of Defense.

1. Scope

1.1 This test method covers the determination of the apparent density of granular activated carbon. For purposes of this test method, granular activated carbon is defined as a minimum of 90 % being larger than 80 mesh.

1.2 The values stated in SI units are to be regarded as standard. No other units of measurement are included in this standard.

1.3 *This standard does not purport to address all of the safety concerns, if any, associated with its use. It is the responsibility of the user of this standard to establish appropriate safety and health practices and determine the applicability of regulatory limitations prior to use.*

2. Referenced Documents

2.1 *ASTM Standards:*²

[D2862 Test Method for Particle Size Distribution of Granular Activated Carbon](#)

[D2867 Test Methods for Moisture in Activated Carbon](#)

[E177 Practice for Use of the Terms Precision and Bias in ASTM Test Methods](#)

[E300 Practice for Sampling Industrial Chemicals](#)

[E542 Practice for Calibration of Laboratory Volumetric Apparatus](#)

3. Summary of Test Method

3.1 Apparent density (bulk density) is determined on a granular sample by measuring the volume packed by a free fall from a vibrating feeder into an appropriately sized graduated cylinder and determining the mass of the known volume. Other methods for determining apparent density of granular or powdered materials exist. These may involve vibration or tapping of the receiving vessel either while it is being filled or afterwards. Application of these methods to granular activated carbon may give packed density values that differ from those determined by this test method.

4. Significance and Use

4.1 This test method provides a method for determining the packed density of a bed of granular activated carbon. Determination of the packed density is essential when designing vessels to hold the material and for ordering purposes when procuring materials to fill existing vessels.

5. Apparatus (see Fig. 1)

5.1 *Reservoir Funnel*, fabricated of glass or metal.

5.2 *Feed Funnel*, glass or metal.

5.3 *Vibratory Feeder*,³ such as shown in Fig. 1 or similar.

5.4 *Cylinders*, graduated 100, 250, or 500 mL, calibrated “to contain” (TC).

¹ This test method is under the jurisdiction of ASTM Committee D28 on Activated Carbon and is the direct responsibility of Subcommittee D28.04 on Gas Phase Evaluation Tests.

Current edition approved April 1, 2009; July 1, 2014. Published May 2009; September 2014. Originally approved in 1970. Last previous edition approved in 2004 as ~~D2854 – 09~~ ~~D2854 – 09~~, (2004). DOI: 10.1520/D2854-09.10.1520/D2854-09R14.

² For referenced ASTM standards, visit the ASTM website, www.astm.org, or contact ASTM Customer Service at service@astm.org. For *Annual Book of ASTM Standards* volume information, refer to the standard’s Document Summary page on the ASTM website.

³ A suitable vibratory feeder is the model F-TO vibrating feeder with standard trough 1½ by 12 in. and controller. This unit is available from FMC Corporation, Material Handling Equipment Division, 57 Cooper Ave., Homer City, PA 15748. Similar equipment is available from other suppliers.

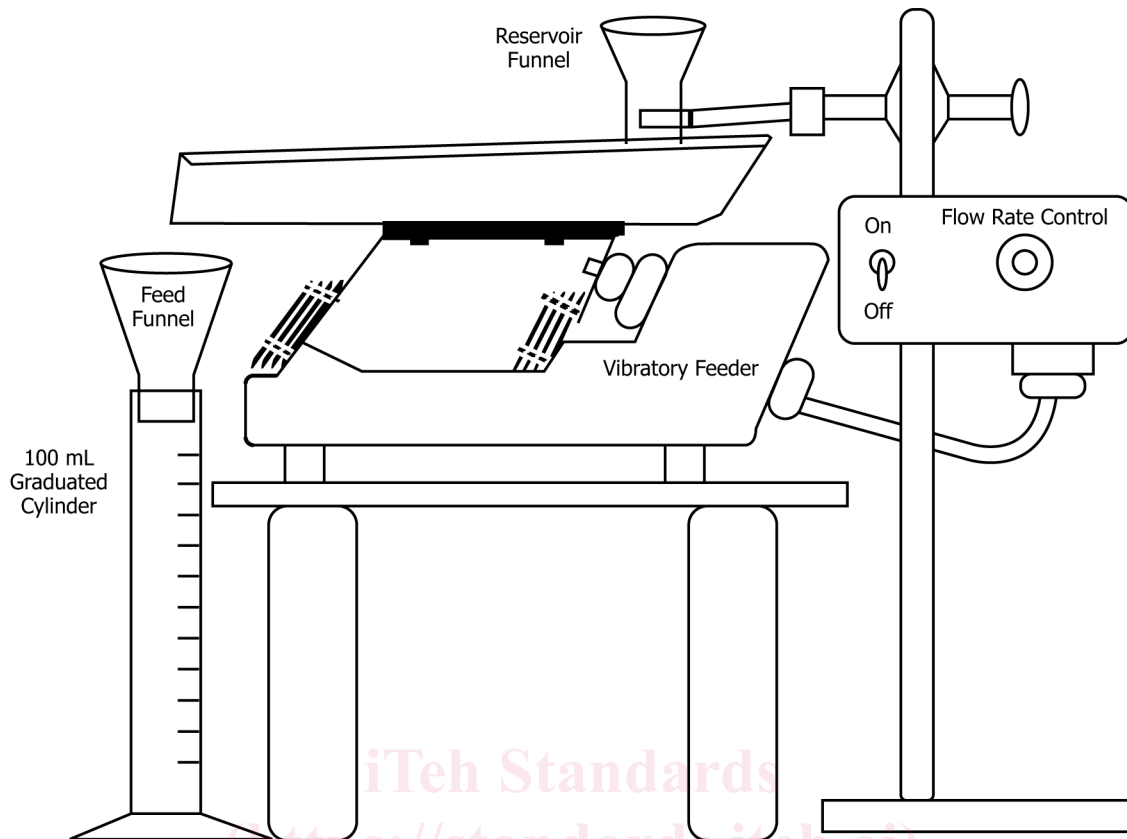

FIG. 1 Assembly of Apparatus

5.5 Balance, having a sensitivity of 0.1 g or better.

6. Procedure

6.1 Select a 100, 250, or 500 mL graduated cylinder appropriate for the particle size of the activated carbon to be tested. The inside diameter of the cylinder shall be at least 10 times the mean particle diameter (MPD) as determined by Test Method D2862.

6.2 If desired, the graduated cylinder may be calibrated by the user in accordance with Practice E542.

6.3 Obtain a representative sample of activated carbon in accordance with Practice E300. Carefully place the sample of activated carbon into the reservoir funnel so that the material does not prematurely flow into the graduated cylinder. If this occurs, return the material to the reservoir funnel.

6.4 The feed funnel should have an outside diameter which just fits inside the chosen graduated cylinder. Adjust the height of the reservoir funnel above the vibrator trough so that a free flow of material is obtained. The drawing in Fig. 1 shows a typical apparatus using a 100 mL TC graduated cylinder.

6.5 Add the sample to the cylinder using the vibratory feeder through the feed funnel. Adjust the flow rate control to fill the cylinder at a uniform rate not less than 0.75 or exceeding 1.0 mL/s up to the mark corresponding to the volume chosen. The graduated cylinder shall be filled to at least 50 % of its capacity.

6.6 Transfer the contents from the cylinder to a balance pan and weigh to the nearest 0.1 g.

7. Calculation

7.1 Calculate the as-received apparent density as follows:

$$\begin{aligned}
 & \text{as-received apparent density, g/mL} \\
 & = \frac{\text{mass of activated carbon in grams}}{\text{carbon volume in millilitres}}
 \end{aligned}
 \tag{1}$$

7.2 Calculate the apparent density on the dry basis as follows: