



Designation: D3803 – 91 (Reapproved 2014)

Standard Test Method for Nuclear-Grade Activated Carbon¹

This standard is issued under the fixed designation D3803; the number immediately following the designation indicates the year of original adoption or, in the case of revision, the year of last revision. A number in parentheses indicates the year of last reapproval. A superscript epsilon (ϵ) indicates an editorial change since the last revision or reapproval.

1. Scope

1.1 This test method is a very stringent procedure for establishing the capability of new and used activated carbon to remove radio-labeled methyl iodide from air and gas streams. The single test method described is for application to both new and used carbons, and should give test results comparable to those obtained from similar tests required and performed throughout the world. The conditions employed were selected to approximate operating or accident conditions of a nuclear reactor which would severely reduce the performance of activated carbons. Increasing the temperature at which this test is performed generally increases the removal efficiency of the carbon by increasing the rate of chemical and physical adsorption and isotopic exchange, that is, increasing the kinetics of the radioiodine removal mechanisms. Decreasing the relative humidity of the test generally increases the efficiency of methyl iodide removal by activated carbon. The water vapor competes with the methyl iodide for adsorption sites on the carbon, and as the amount of water vapor decreases with lower specified relative humidities, the easier it is for the methyl iodide to be adsorbed. Therefore, this test method is a very stringent test of nuclear-grade activated carbon because of the low temperature and high relative humidity specified. This test method is recommended for the qualification of new carbons and the quantification of the degradation of used carbons.

1.1.1 Guidance for testing new and used carbons using conditions different from this test method is offered in **Annex A1**.

1.2 The values stated in SI units are to be regarded as standard. No other units of measurement are included in this standard.

1.3 *This standard does not purport to address all of the safety concerns, if any, associated with its use. It is the responsibility of the user of this standard to establish appropriate safety and health practices and determine the applicability of regulatory limitations prior to use.*

¹ This test method is under the jurisdiction of ASTM Committee D28 on Activated Carbon and is the direct responsibility of Subcommittee D28.04 on Gas Phase Evaluation Tests.

Current edition approved July 1, 2014. Published September 2014. Originally approved in 1979. Last previous edition approved in 2009 as D3803 – 91 (2009). DOI: 10.1520/D3803-91R14.

2. Referenced Documents

2.1 ASTM Standards:²

D1193 Specification for Reagent Water

D2652 Terminology Relating to Activated Carbon

D2854 Test Method for Apparent Density of Activated Carbon

E300 Practice for Sampling Industrial Chemicals

E691 Practice for Conducting an Interlaboratory Study to Determine the Precision of a Test Method

2.2 Code of Federal Regulations:

CFR Title 49, Section 173.34, “Qualification, Maintenance, and Use of Cylinders”³

CFR Title 49, Part 178, Subpart C, “Specifications for Cylinders”³

2.3 Military Standards:

MIL-F-51068D Filter, Particulate High Efficiency, Fire Resistant⁴

MIL-F-51079A Filter, Medium Fire Resistant, High Efficiency⁴

MIL-STD-45662 Calibration Systems Requirements⁴

2.4 Other Standards:

ANSI/ASME N45.2.6 Qualifications of Inspection, Examination, and Testing Personnel for Nuclear Power Plants⁵

3. Terminology

3.1 Definitions of Terms Specific to This Standard:

3.1.1 *counter efficiency (CE)*—the fraction of the actual number of disintegrations of a radioactive sample that is recorded by a nuclear counter.

3.1.2 *efficiency (E)*—the percentage of the contaminant removed from a gas stream by an adsorption bed; expressed mathematically as $E = 100 - P$, where E and P are given in percent.

² For referenced ASTM standards, visit the ASTM website, www.astm.org, or contact ASTM Customer Service at service@astm.org. For *Annual Book of ASTM Standards* volume information, refer to the standard’s Document Summary page on the ASTM website.

³ Published by the General Service Administration, 18th and “F” St., N. W., Washington, DC 20405.

⁴ Available from Standardization Documents Order Desk, DODSSP, Bldg. 4, Section D, 700 Robbins Ave., Philadelphia, PA 19111-5098, <http://dodssp.daps.dla.mil>.

⁵ Available from American National Standards Institute (ANSI), 25 W. 43rd St., 4th Floor, New York, NY 10036, <http://www.ansi.org>.

3.1.3 *penetration (P)*—the percentage of the contaminant (CH_3I) which passes through the equilibrated test bed of standard depth, and is collected on the backup beds during the feed and elution periods under specified conditions.

3.1.4 *relative humidity (RH)*—for the purpose of this test method, relative humidity is defined as the ratio of the partial pressure of water in the gas to the saturation vapor pressure of water at the gas temperature and pressure. At temperatures below 100°C , this is the normal definition and relative humidity can range from 0 to 100 %.

3.2 *Definitions*—for additional terms relating to this standard, see Terminology D2652.

4. Summary of Test Method

4.1 Both new and used carbons are first exposed to humid air (pressure, approximately 1 atm; temperature, 30.0°C ; relative humidity, 95 %) for a *pre-equilibration* period of 16 h. During this pre-equilibration period, the test system may be run unattended with the required parameter monitoring and adequate control devices. Following pre-equilibration, the air flow is continued for a two-hour *equilibration* period, during which the acceptable variability of all parameters is reduced. The test system must be closely monitored and controlled during the final four hours of the test. Qualification of personnel to perform this testing must meet or exceed ANSI/ASME N45.2.6—1978, Level II, which requires a combination of education and actual test system operation experience. During the *challenge* or feed period, radio-labeled methyl iodide at a mass concentration of 1.75 mg/m^3 of humid air flow is passed through the beds for a period of 60 min. Following the feed period, humid air flow without test adsorbate is continued at the same conditions for a 60-min elution period. Throughout the entire test, the effluent from the sample bed passes through two backup beds containing carbon having a known high efficiency for methyl iodide. The two backup beds trap essentially all the radio-labeled methyl iodide that passes the test bed and provide a differential indication of their efficiency. At the end of the elution period, the gamma activity of ^{131}I in the test and backup beds is measured by a gamma counter, and the percent of adsorbate penetrating the test bed is determined.

5. Significance and Use

5.1 The results of this test method give a conservative estimate of the performance of nuclear-grade activated carbon used in all nuclear power plant HVAC systems for the removal of radioiodine.

6. Apparatus

6.1 Sample Preparation Apparatus:

6.1.1 *Riffle Sampler*, in accordance with 32.5.2 of Practice E300.

6.1.2 *Feed Funnel and Vibrator*, in accordance with the Procedure Section of Test Method D2854.

6.2 Sample and Backup Bed Assemblies:

6.2.1 The sample bed canister and backup bed canisters must each be either a single unit capable of containing carbon

to a depth of $50 \pm 1 \text{ mm}$, or they may be assembled from two separate units each capable of containing carbon to a depth of 25 mm. Two backup canisters, each of $50 \pm 1 \text{ mm}$ total depth, are required. Canisters may be reused after being decontaminated to remove residual radioactivity. An acceptable bed construction is shown in Fig. 1 with critical dimensions noted.

6.2.2 Clamping assemblies are needed for sample and backup beds. The only requirements for these assemblies are that they provide a smooth sealing face, uniform alignment of bed canisters, and sufficient clamping force so that the leak test in 10.2 can be met. A suggested design for clamping assemblies is shown in Fig. 2.

6.3 A schematic of a generalized test system is shown in Fig. 3. This system is designed to operate at approximately 30°C and 95 % relative humidity, with a gas flow of 24.7 L/min

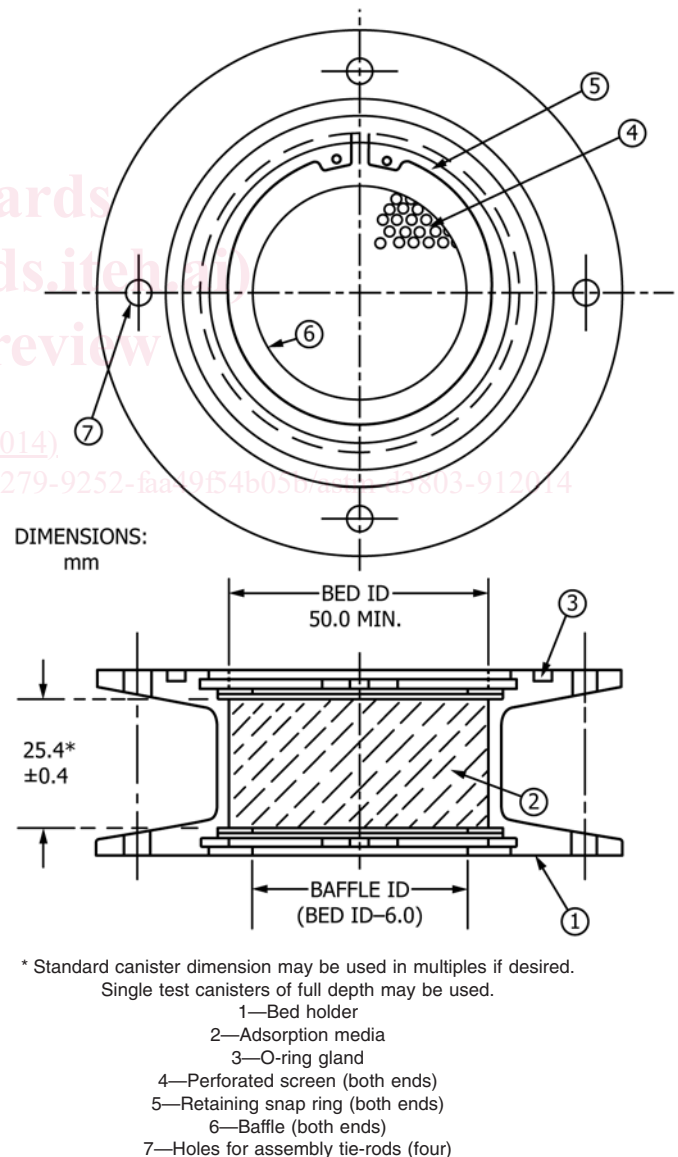

FIG. 1 Adsorption Media Test Bed Holder (Canister)

TABLE 1 Parameter Specifications

NOTE 1—Temperature, relative humidity, pressure, and gas velocity are to remain constant within the specified maximum variations throughout the entire test, that is, for each test period. Parameter excursions outside the limits specified in this table will invalidate the test results. If results based on a test containing such variations must be reported, then these variations must be noted in the comments section of the external report form and flagged in the parameter monitoring portion of the internal report.

Parameter	Pre-Equilibration (First 16 h)	Equilibration, Challenge, and Elution (Final 4 h)
Temperature, °C	30.0 ± 0.4	30.0 ± 0.2
Range	29.6 to 30.4	29.8 to 30.2
Relative humidity, %	91.0 to 96.0	93.0 to 96.0
Flow, m/min	12.2 ± 0.6	12.2 ± 0.3
Face velocity, m/min	11.6 to 12.8	11.9 to 12.5
Absolute pressure, kPa	101 ± 5	101 ± 5
Bed diameter and depth, mm	50 ± 1	50 ± 1
Adsorbate concentration, mg/m ³	...	1.75 ± 0.25
Test durations:		
Pre-equilibration, h	16.0 ± 0.1	...
Equilibration, min	...	120 ± 1
Challenge, min	...	60 ± 1
Elution, min	...	60 ± 1

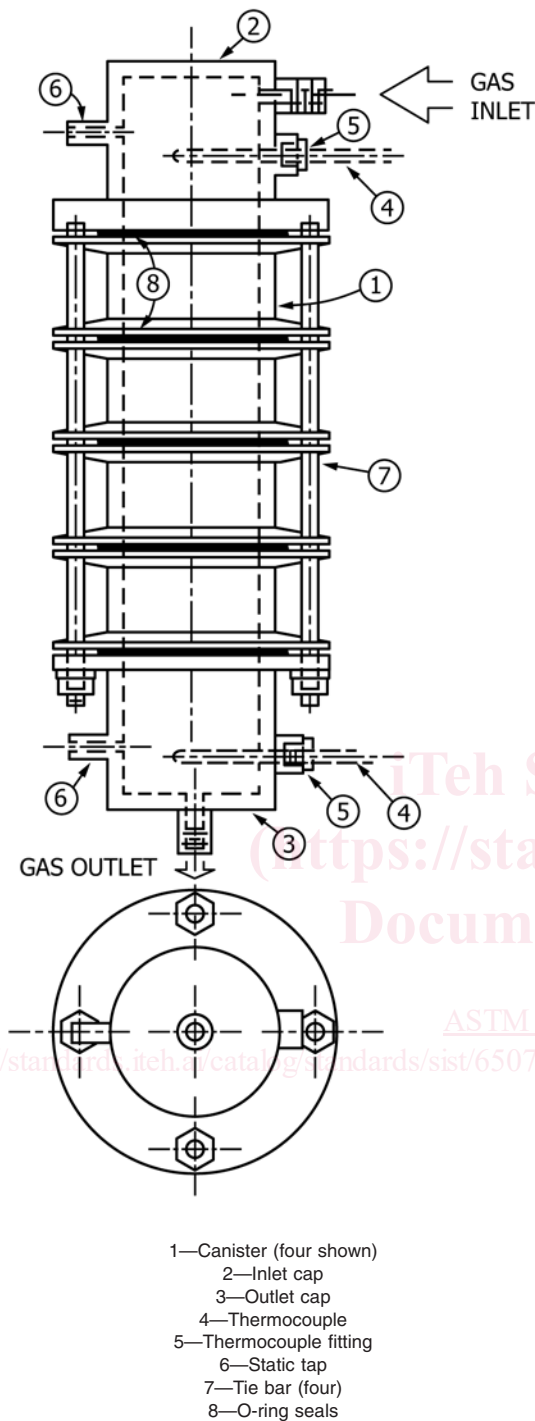

FIG. 2 Canister Assembly (Test or Backup Beds)

at atmospheric pressure. If test conditions which differ significantly from these are required, then separate calibrations or instrumentation, or both, may be required.

6.4 *Saturator System*—This system may be a controlled temperature saturator (bubbler) or spray chamber (environmental condition generator), or any other device of sufficient stability and capacity to supply the required mass flow of water vapor at test conditions.

6.5 *Flow Generator*—This system may be an air compressor upstream of the test system or a vacuum pump downstream of the test system. A dryer, carbon adsorber, and HEPA (high-efficiency particulate air) filter are required for either system to condition the inlet air. Flow measurement and control should be accurate and stable to within ±2 % of specified flow rate. System capacity shall meet or exceed the volumetric flow requirements as calculated from the specified face velocity. A surge tank and pressure control valve should be employed in either type of system to ensure stable and accurate flow measurement and control. For safety, it is important that the pressure system be equipped with a pressure relief valve. It is important that the pipe diameter and inlet air filters for a vacuum system be designed and maintained to minimize the pressure drop from ambient to ensure that the specifications for absolute pressure at the test bed are met (see Table 1).

6.6 *Moisture Separator*—A moisture separator should be used to protect the HEPA filter by removing large quantities of entrained particulate water, if present, after humidification. A HEPA filter (or equivalent) is required to function as a final droplet trap to remove small amounts of fine particulate water from the carrier gas ahead of the test bed.

6.7 *Adsorbate Supply*—This system shall consist of a stainless steel cylinder, pressure gage, pressure regulator, and a flow regulator capable of providing a steady flow of the challenge gas, that is, radio-labeled methyl iodide in dry nitrogen, for the duration of the test feed period. The point of injection into the main gas flow of the system must be such that the cross-sectional distribution of the adsorbate at the face of the test bed can be ensured to be homogeneous. A mixing chamber, baffles, glass beads, etc. should be used to achieve adequate mixing.

6.8 *Constant Temperature Cabinet*—An enclosure and associated thermoregulatory system must be used that is capable of maintaining the inlet gas stream temperature from the point of humidity control to the test bed, and the surface temperature of

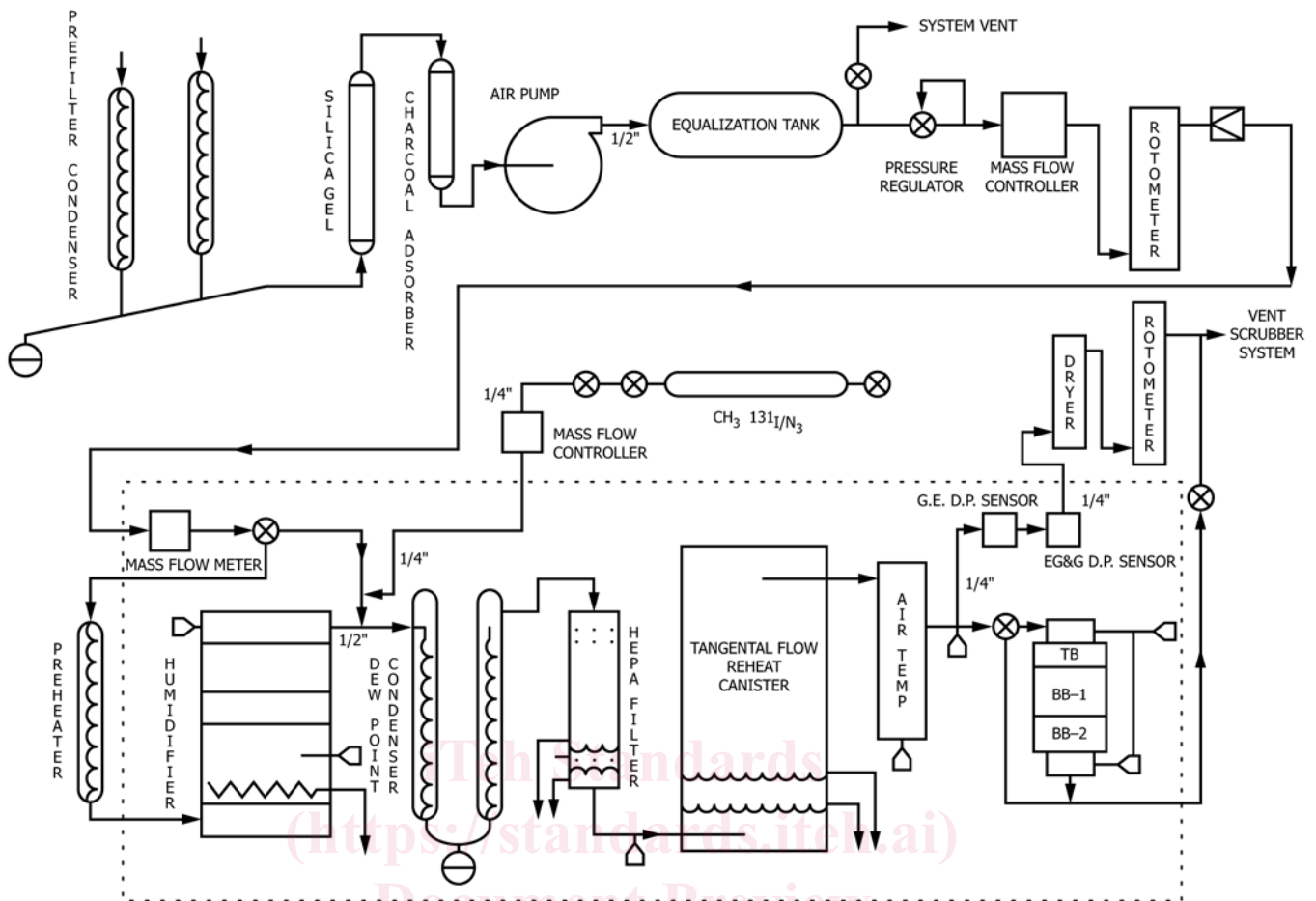

FIG. 3 Schematic of Activated Carbon Test System

all carbon canisters at $30.0 \pm 0.2^\circ\text{C}$, except during the first several hours of pre-equilibration, during which the adsorption of water by the carbons may increase these temperatures slightly. All tubing downstream of the moisture separator, the carbon bed canisters and holders, temperature and pressure ports and measurement devices upstream and downstream of the test bed, and an upstream port and tubing to the dew point sensor all must be included within the temperature controlled enclosure. In addition, it is highly recommended that a bypass line be included around the sample bed assembly to avoid exposing the sample to start-up conditions possibly outside those specified.

6.9 Flow Measurement and Control—Mass flow controllers, control valve and orifice meter, rotameter or any other device with adequate stability and demonstrated measurement system accuracy of $\pm 2\%$ of specified flow rate at the test conditions. All flow measuring devices must use correction factors for interpretation and application to actual test conditions. These factors must be carefully predetermined and documented. No flow measuring device should be located directly downstream of the test bed such that it is subject to variable temperature and humidity conditions during a test as a result of water absorption by the carbon.

6.10 Interconnecting Tubing—Tubing must be non-reactive with methyl iodide, such as stainless steel, glass, etc., with a minimum of $\frac{3}{8}$ -in. outside diameter, and kept as short as possible to reduce the system pressure drop.

6.11 Temperature Measurement Devices—Platinum resistance thermometers (RTDs) with certified accuracy and measurement system calibration to $\pm 0.2^\circ\text{C}$ are required for the measurement of test bed inlet air temperature and dew point. The placement of the air temperature RTD must be such that it is not subject to radiative heating from the test bed. It is critical to the exact measurement of relative humidity that the chilled mirror RTD and the inlet air temperature RTD be matched exactly ($\pm 0.1^\circ\text{C}$) or that differences are exactly corrected for in relative humidity calculations.

6.12 Pressure Measurement Devices—Absolute pressure measuring devices must be accurate to within $\pm 1\%$ of the reading at standard atmospheric pressure and be capable of digital or analog output to meet the specified recording requirements. The sensors and output devices must be calibrated as a unit to ensure system accuracy. The differential pressure device required for measurements across the test bed must be capable of detecting a 0.25 kPa pressure difference and

be accurate to within $\pm 2\%$ of the reading at the normal operating differential pressure.

6.13 Humidity Measurement—A humidity measuring device with demonstrated accuracy and calibration to $\pm 0.2^\circ\text{C}$ at 30°C and 95 % relative humidity is required for measurement of relative humidity of the gas stream immediately upstream of the test bed. Note that for these test conditions only an optical dew point hygrometer currently meets these specifications. A secondary check on this measurement device is required to ensure that calibration offset has not occurred. This secondary device may be another optical dew point hygrometer, wet bulb/dry bulb, or any other device with a demonstrated accuracy of $\pm 3\%$ relative humidity. For this application, absolute accuracy is less important than reliability and reproducibility.

6.14 Data Recording—To meet the reporting requirements for internal reports (see 14.3), the use of potentiometric recorders or a data logger capable of recording temperatures, pressures, flow, and relative humidity data a minimum of once every five minutes is required

6.15 Gamma Detection System—Any reliable and efficient detection system for gamma rays of 365 keV energy is permissible, provided it produces actual counts of gamma photons and not an analog rate output, and provides adequate elimination of any interferences that might be present. Systems equipped with internal computers that make calculations or corrections for such things as dead time, counting efficiency, decay rates, etc. are also permissible, provided they give accuracy equal to that required in this standard. In many cases, either thallium-activated sodium iodide well counters or single- or multi-channel gamma spectrometers that use thallium-activated sodium iodide, lithium-drifted germanium, or intrinsic germanium detectors can be used with appropriate professional guidance, proper shielding, and preferably graded absorbers of cadmium and copper to reduce the production of X-rays in the shielding. When significant gamma-emitting interferences are absent and penetration of iodine-131 (^{131}I) through the test bed is greater than a few tenths of one percent, either the principal ^{131}I photopeak at 364.46 keV or the entire spectrum including the Compton continuum can be used. However, when the penetration is low, a multi-channel spectrometer with a germanium detector will be required for the most accurate measurements. This is necessary to identify the ^{131}I in the presence of the lead-214 daughter of radium-226 generally present in carbon, and to permit Compton correction for gamma-emitters such as potassium-40 and daughters of radium-226. The test bed, backup beds, and carbon backgrounds must all be counted under identical geometrical conditions. This requires the use of a jig on the detector to hold each counting bottle in identically ($\pm 1\text{ mm}$) the same position.

7. Materials

7.1 Air—Compressor, used for pressure systems, should be of the oil-free type to minimize injection of hydrocarbons into the system. Line filters shall consist of a dryer, activated carbon, and HEPA filters and shall be adequately sized and maintained.

7.2 Water—Specification **D1193** Type III reagent water, deionized or distilled, or both, must be used for water-vapor generation.

7.3 Radio-Labeled Methyl Iodide—Methyl iodide solution should be stored in the dark below 0°C to slow its decomposition to I_2 . The activity of ^{131}I should be such that the total activity incident upon the detector in the entire spectrum from the test bed is between 10^3 and 5×10^5 counts/min.

7.4 Backup Bed Carbon, with a penetration of no more than 3 % when tested by this test method. The calculation of the efficiency of the first backup bed is required for each test.

7.5 HEPA Filter Media—In accordance with MIL-F-51079A. If a pleated filter is used in place of a flat sheet, it shall be constructed in accordance with MIL-F-51068D.

8. Hazards

8.1 Warning—Overpressure —The contaminant feed system makes use of dry nitrogen from standard high-pressure gas cylinders, a contaminant feed cylinder which is pressurized, and associated regulators and tubing for transport of the contaminant gas. This system must be designed with adequate safety factors. Standards for the fabrication of such pressure vessels and associated fittings are contained in 49 CFR 173.34. Elastomeric seals must be replaced on a regular basis or if damaged to ensure system integrity.

8.2 Warning—Radioactivity —The radiotoxicity of ^{131}I is well documented. The species used in this test is very volatile and easily inhaled. Rigorous health physics procedures must be followed whenever handling the radioisotope and routine thyroid counting must be provided for laboratory personnel. The system must be adequately vented through a filter system capable of handling the maximum possible contaminant release. Radiation shielding and dosimetry must be provided to limit and monitor worker exposures in compliance with federal and state nuclear regulations. Personnel access to the system should be strictly limited and workers should be trained in health physics procedures.

9. Sampling

9.1 Guidance in sampling granular activated carbon is given in Practice **E300**.

9.2 Occasionally, samples received for laboratory analysis are not of sufficient quantity to fill the test canister to the standard depth of 5.08 cm (2 in.). If possible, another sample should be obtained. However, this is not always possible because of critical time constraints. If a substandard quantity of carbon must be tested, the resulting actual penetration value must be converted to the predicted penetration at the standard depth and noted as such on both the internal and external report forms. This conversion is based on the log-linear function of penetration with depth and is expressed as in **Eq 1**.

$$P_s = 100\exp\{\ln(P_a/100)(5.08/d)\} \quad (1)$$

where:

P_s = predicted penetration at the standard depth, %, and
 P_a = actual penetration at the substandard depth, %, and

d = substandard depth, cm.

10. Preparation of Apparatus

10.1 Fill a set of back-up canisters and test canister(s) using the procedure in Test Method [D2854](#), with the delivery funnel modified to accommodate the canister diameter. Count the background radioactivity in each canister (both test and back-up) according to [12.7](#) and [12.8](#), then refill the canisters using the procedure in Test Method [D2854](#).

10.2 Leak testing of the system designed to test carbon at standard atmospheric pressure should be performed on a routine basis, and is recommended prior to each test. This test should be a pressure decay test for pressure induced flow systems or a vacuum decay test for vacuum induced flow systems. The system should be pressurized to approximately 125 kPa or depressurized to approximately 75 kPa with filled test and backup canisters in place. The system should then be isolated, that is, sealed at all atmospheric connections, and the pressure change with time recorded. The system should be made as leak tight as possible. However, a maximum leak rate should not exceed 5 kPa pressure change in 30 min to ensure the accuracy of flow measurement. A more stringent leak rate requirement may be necessary because of health physics considerations. These calculations should be performed by each laboratory for each unique situation.

10.3 To ensure the accuracy of relative humidity measurement, a check of the differential pressure between the test bed and the sensor of the optical dew point hygrometer should be performed initially and whenever the system is modified, or semi-annually. This check should be performed with the test and backup canisters filled with carbon and with the system operating at the standard conditions specified, that is, temperature, flow, relative humidity, pressure, etc. This differential pressure should not exceed 1 kPa or must be corrected for either in the calculation of relative humidity, or preferably, by modification of the test system to reduce the pressure difference.

10.4 Correction factors for flow measurement devices, especially rotameters, must be predetermined by the comparison of accurate pressure (± 1.0 kPa) and temperature ($\pm 0.2^\circ\text{C}$) measurements made at the device and at the test bed under normal operating conditions. Correction of the measured flow to the actual flow at test bed for temperature, pressure, and water vapor can be made using [Eq 2](#):

$$Q_A = \frac{(Q_M)(T_A)(P_M)}{(T_M)(P_A)} \left(1 + \frac{P_{H_2O}}{P_A} \right) \quad (2)$$

where:

- Q_A = actual gas flow at the test bed, L/min,
- Q_M = flow of gas at the flow measurement device, L/min,
- T_A = actual gas temperature at the test bed, $^\circ\text{K}$,
- T_M = gas temperature at flow measurement device, $^\circ\text{K}$,
- P_A = actual gas pressure at the test bed, kPa,
- P_M = gas pressure at flow measurement device, kPa, and
- P_{H_2O} = partial pressure of water vapor at test bed, kPa.

10.4.1 No flow measuring device should be located directly downstream of the test bed such that it is subject to variable

temperature and humidity conditions during a test as a result of water adsorption by the carbon.

11. Calibration

11.1 The RTDs used to measure the test bed inlet gas temperature and the chilled mirror temperature of the dew point hygrometer must be calibrated together every six months by the National Institute of Standards and Technology (NIST) or a third party capable of certification to NIST standards. Check the hygrometer accuracy at the same time. In addition, the primary flow measuring device should also be calibrated every six months by NIST or a third party capable of certification to NIST standards. Other temperature, flow and pressure measuring devices, balances, radiation survey meters, and gamma detection systems shall be part of an established laboratory calibration program as specified in MIL-STD-45662, with initial calibration intervals of one month and periodic calibration intervals determined on the basis of instrument stability, purpose, and degree of usage. It is important to note that the measurement systems, that is, sensors, associated electronics, displays, etc., must be calibrated individually and together to ensure that the particular parameter monitoring system meets the accuracy and precision requirements.

12. Procedure

12.1 *Stabilization Period*—Install the filled test and backup canisters in the system. Perform the leak test described in [10.2](#) to ensure system integrity. Bring the system up to operating conditions (see [Table 1](#)) prior to the start of pre-equilibration. The duration of this stabilization period is recommended to be a minimum of 2 h, during which the canisters and carbon must come to thermal equilibrium at the specified test temperature.

12.2 *Pre-Equilibration Period (for new and used carbons)*—Pass air with 95 % relative humidity (range, 91.0 to 96.0 %) at a temperature of $30.0 \pm 0.4^\circ\text{C}$ through the beds for 16.0 ± 0.1 h. There will be a sudden change in relative humidity at the start of pre-equilibration that will produce a rapid temperature rise in the carbon caused by the heat of adsorption of water. The extent of this temperature rise cannot be controlled and depends upon the condition of the carbon. The conditions at the test bed inlet must be held at the specified conditions (see [Table 1](#)).

12.3 *Equilibration Period (for new and used carbons)*—Continue to pass air with 95 % relative humidity (range, 93.0 to 96.0 %) at a temperature of $30.0 \pm 0.2^\circ\text{C}$ through the beds for 120 ± 1 min. This is the critical time prior to challenge during which all conditions must be within their most stringent control limits.

12.4 *Challenge Period (Feed)*—Humid air flow is already at the prescribed conditions (see [Table 1](#)) at the start of the feed period. Maintain flow at $30.0 \pm 0.2^\circ\text{C}$ at 95 % relative humidity (range, 93.0 to 96.0 %) for 60 ± 1 min with 1.75 ± 0.25 mg/m³ of radio-labeled CH₃I in the total system gas flow provided by the addition of a small and continuous flow of the challenge gas during the feed period.

12.5 *Elution Period*—To evaluate the ability of the carbon to hold the adsorbate once it is captured, continue flow at the