



Designation: **E290–13** E290 – 14

Standard Test Methods for Bend Testing of Material for Ductility¹

This standard is issued under the fixed designation E290; the number immediately following the designation indicates the year of original adoption or, in the case of revision, the year of last revision. A number in parentheses indicates the year of last reappraisal. A superscript epsilon (ϵ) indicates an editorial change since the last revision or reappraisal.

This standard has been approved for use by agencies of the U.S. Department of Defense.

1. Scope-~~Scope~~*

1.1 These test methods cover bend testing for ductility of materials. Included in the procedures are four conditions of constraint on the bent portion of the specimen; a guided-bend test using a mandrel or plunger of defined dimensions to force the mid-length of the specimen between two supports separated by a defined space; a semi-guided bend test in which the specimen is bent, while in contact with a mandrel, through a specified angle or to a specified inside radius (r) of curvature, measured while under the bending force; a free-bend test in which the ends of the specimen are brought toward each other, but in which no transverse force is applied to the bend itself and there is no contact of the concave inside surface of the bend with other material; a bend and flatten test, in which a transverse force is applied to the bend such that the legs make contact with each other over the length of the specimen.

1.2 After bending, the convex surface of the bend is examined for evidence of a crack or surface irregularities. If the specimen fractures, the material has failed the test. When complete fracture does not occur, the criterion for failure is the number and size of cracks or surface irregularities visible to the unaided eye occurring on the convex surface of the specimen after bending, as specified by the product standard. Any cracks within one thickness of the edge of the specimen are not considered a bend test failure. Cracks occurring in the corners of the bent portion shall not be considered significant unless they exceed the size specified for corner cracks in the product standard.

1.3 The values stated in SI units are to be regarded as standard. Inch-pound values given in parentheses were used in establishing test parameters and are for information only.

1.4 *This standard does not purport to address all of the safety concerns, if any, associated with its use. It is the responsibility of the user of this standard to establish appropriate safety and health practices and determine the applicability of regulatory limitations prior to use.*

2. Referenced Documents

2.1 *ASTM Standards:*²

[E6 Terminology Relating to Methods of Mechanical Testing](#)

[E8/E8M Test Methods for Tension Testing of Metallic Materials](#)

[E18 Test Methods for Rockwell Hardness of Metallic Materials](#)

[E190 Test Method for Guided Bend Test for Ductility of Welds](#)

3. Summary of Test Methods

3.1 Four methods for ductility testing employing bending are included in these test methods. Three methods have subgroups with specific procedures.

3.1.1 *Guided Bend:*

3.1.1.1 Guided Bend, No Die,

3.1.1.2 Guided Bend, U-Bend,

3.1.1.3 Guided Bend, V-Bend,

3.1.1.4 Guided Bend, V-Bend for cold rolled sheet,

¹ This test method is under the jurisdiction of ASTM Committee E28 on Mechanical Testing and is the direct responsibility of Subcommittee E28.02 on Ductility and Formability.

Current edition approved April 1, 2013; May 1, 2014. Published May 2013; September 2014. Originally approved in 1966. Last previous edition approved in 2009 as E290–09; E290–13. DOI: 10.1520/E0290-13-10.1520/E0290-14.

² For referenced ASTM standards, visit the ASTM website, www.astm.org, or contact ASTM Customer Service at service@astm.org. For *Annual Book of ASTM Standards* volume information, refer to the standard's Document Summary page on the ASTM website.

*A Summary of Changes section appears at the end of this standard

3.1.2 *Semi-guided Bend:*

3.1.2.1 *Arrangement A*, specimen held at one end.

3.1.2.2 *Arrangement B*, for thin material.

3.1.2.3 *Arrangement C*, mandrel contact force in the bend.

3.1.3 *Free-Bend:*

3.1.3.1 *Type 1*, 180° bend.

3.1.3.2 *Type 2*, bend flat on itself.

3.1.4 *Bend and Flatten:*

3.2 A guided-bend test for ductility of welds is described in Method **E190** and may be used for flat-rolled materials when specified by the product standard. The essential features of this bending method are employed in **3.1.1.2**, Guided Bend, U-Bend.

3.3 Bend tests are made in one of two directions relative to the principal working direction employed in production processing of the material.

3.3.1 Longitudinal tests use a specimen with its long dimension aligned with the processing direction such that the bend is formed across the processing direction, as shown in **Fig. 1**.

3.3.2 Transverse tests use a specimen with the long dimension perpendicular to the processing direction so that the bend axis is aligned with the processing direction, as shown in **Fig. 2**. The axis of bend is the center of the bend radius.

3.3.3 Thin sheet products are generally produced by reducing the thickness of stock in rolling mills and from this the term rolling direction is used to identify the principal processing direction. Similarly, a product produced in coil form may have the processing direction referred to as the coiling direction.

3.4 The location of the force application to the specimen relative to the bend itself and the amount of bending differentiate the four methods of bending covered in these test methods. The two semi-guided bend test procedures provide radiused surfaces over which the bend is formed. The results obtained by different test procedures may not be the same, especially for material with a tendency to crack or fracture.

3.5 The test is completed when the designated angle of bend, or other specified condition, has been reached.

3.5.1 If a defined amount of cracking is permitted by the product standard, the convex surface of the bend region is examined for cracks and surface irregularities.

3.5.2 Surface irregularities, such as orange peel, loss of coating adherence, or imperfections resulting from the bend, shall be noted as required by the product specification.

3.6 *Guided Bend*—The guided-bend test is made by supporting the specimen near each end on pins, rollers, or flat surfaces with appropriate end radii and applying a force through a pin, mandrel, plunger, or male die midway between two supports, as shown schematically in **Fig. 3**, **Fig. 4**, **Fig. 5**, and **Fig. 6** until the desired bend is formed. No force is applied directly to the outer face of the bend when no female die is used (**3.1.1.1**). Some force may be applied by the female die to the outer face of the bend in the case of U-bend (**3.1.1.2**) and V-bends (**3.1.1.3** and **3.1.1.4**). In some cases, for U-bend and V-bends it may be necessary for the specimen to bottom out in the female die to ensure the correct amount of bending.

3.6.1 The radii of the plunger and of the two supports shall be defined in the product specification as related to the thickness (t) of the specimen being tested. A clearance of three thickness with a tolerance of one half thickness shall be provided between the pins, plunger, and specimen in the initial bend fixture.

3.6.1.1 The distance between supports (C) shall be three thicknesses plus twice the plunger radius, with a tolerance of one-half thickness, as shown in **Fig. 3**.

3.6.1.2 When female dies are used for U-bend and V-bend, they shall conform approximately to the geometries shown in **Fig. 4**, **Fig. 5**, and **Fig. 6**.

3.6.2 The surfaces of the supports and plunger shall be harder than the material tested. Refer to Test Method **E18** other permanent deformation of the test fixtures does occur, the test is invalid.

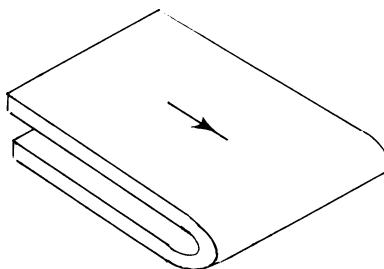

NOTE 1—Arrow indicates direction of processing.

FIG. 1 Longitudinal Bend Test

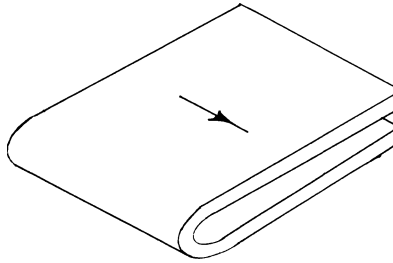

NOTE 1—Arrow indicates direction of processing.
FIG. 2 Transverse Bend Test

NOTE 1—Supports and plungers hardened to at least 20 HRC have been found to be generally suitable for this test. It is recommended that checking by the unaided eye for flattening, wear, or other deformation of the test fixtures take place after testing different and potentially harder materials than usual.

3.6.3 The supports can be fixed or free to rotate. A lubricant may be applied to the supports and plunger.

3.6.4 The width of the guided-bend fixture, including the supports and plunger, shall be such that the bend region of the specimen is subject to the bending force across its width (w) during bending.

3.6.5 When the thickness or strength of the specimen, or capacity of the guided-bend test fixture (shown in Fig. 3) does not produce the required amount of bending, the specimen can be removed from the fixture and the bend completed by applying force against the ends of the specimen, as shown schematically in Fig. 7. A spacer with a thickness equal to twice the required bend radius is inserted at the location of the bend. The edges at the ends shall be constrained so the specimen cannot eject from the fixture under the bending force.

3.6.6 Surface cracks and imperfections resulting from the bend shall be evaluated and reported.

3.7 *Semi-guided Bend*—The semi-guided bend test employs a constraining force on the inside of the bend during the initiation of the bending and continuing until the final bend condition is achieved.

3.7.1 The semi-guided bend test is made by applying a force transversely to the specimen's long axis in the portion that is being bent.

3.7.2 The angle of bend in the semi-guided bend test is measured while the specimen is held stationary under the force forming the bend.

3.7.3 The location of the bend along the length of the specimen is unimportant. The specimen is clamped or supported by one of the methods shown schematically in Figs. 8-10. It is possible that different results will be obtained with the use of different devices. The method used shall be described in the test report on the ductility of the material being evaluated.

3.7.4 *Arrangement A—One End Held*—Arrangement A involves holding one end of the semi-guided bend specimen and applying a force transversely near the free end as in Fig. 8. The bend is formed around a stationary pin, mandrel, or roller of a specified radius. Bending is continued until failure occurs or the specified angle of bend has been achieved.

3.7.5 *Arrangement B—Thin Materials*—Arrangement B is for semi-guided bend tests of thin specimens, and includes a support between the clamp and the bend radius, as shown schematically in Fig. 9. No tension force is applied to the specimen during the bending. The results should be the same for tests using either Arrangement A, or Arrangement B.

3.7.6 *Arrangement C—Mandrel Contact on Outer Surface*—Arrangement C employs a stationary pin, or mandrel, over which the semi-guided bend specimen is bent by the force of a roller, or mandrel, in contact with the outer surface of the bend (as shown schematically in Fig. 10). This may exert a small tension force in the bend. The test is sometimes referred to as a *wrap*, but it is distinct from the *wrap around wire* test described in Method E6.

3.7.7 Surface cracks and irregularities resulting from the bend shall be evaluated and reported.

3.8 *Free-Bend*—The free-bend test is made with no external force applied to the specimen in the immediate area of the bend.

3.8.1 The force to initiate bending for a free-bend test shall be applied at, or within one width distance from, the ends of the specimen. This may be done by gripping the specimen. If the material is too stiff to respond to such force it shall be supported at the mid-length (as shown schematically in Fig. 11) over a span of at least the specimen width while the initial force is applied near the two ends of the specimen.

3.8.2 The angle of a free-bend is measured once the specimen has been removed from the bending fixture and is under no constraining force. There is no radius of bend measurement required for a free-bend test.

3.8.3 *Type 1-Free-Bend—180° Bend*—The bending is initiated as described in 3.8.1 and is then continued until a 180° bend is developed by applying force to bring the legs of the specimen to a parallel position (as shown schematically in Fig. 12).

3.8.4 *Type 2-Free Bend (Flat on Itself Bend)*—The legs of the specimen are placed under flat platens and compressed to contact no closer than one width of specimen distance from the outer extension of the bend (as shown schematically in Fig. 13).

3.8.5 The bending force is more severe in a Type 2-Free-Bend test than in a Type 1-Free-Bend test. For this reason, the type of bending used shall be described in the report.

3.8.6 Materials that age harden at room temperature shall be tested within the allowed period of time, as defined in the product standard.

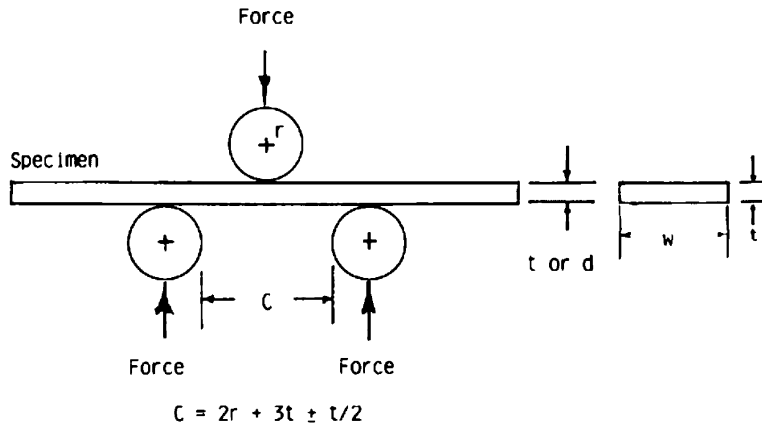

NOTE 1— C = distance between lower supports,
 r = radius of the end of the mandrel or plunger,
 t = sheet specimen thickness,
 d = round specimen diameter, and
 w = sheet specimen width.

FIG. 3 Schematic Fixture for the Guided Bend, No Die Test

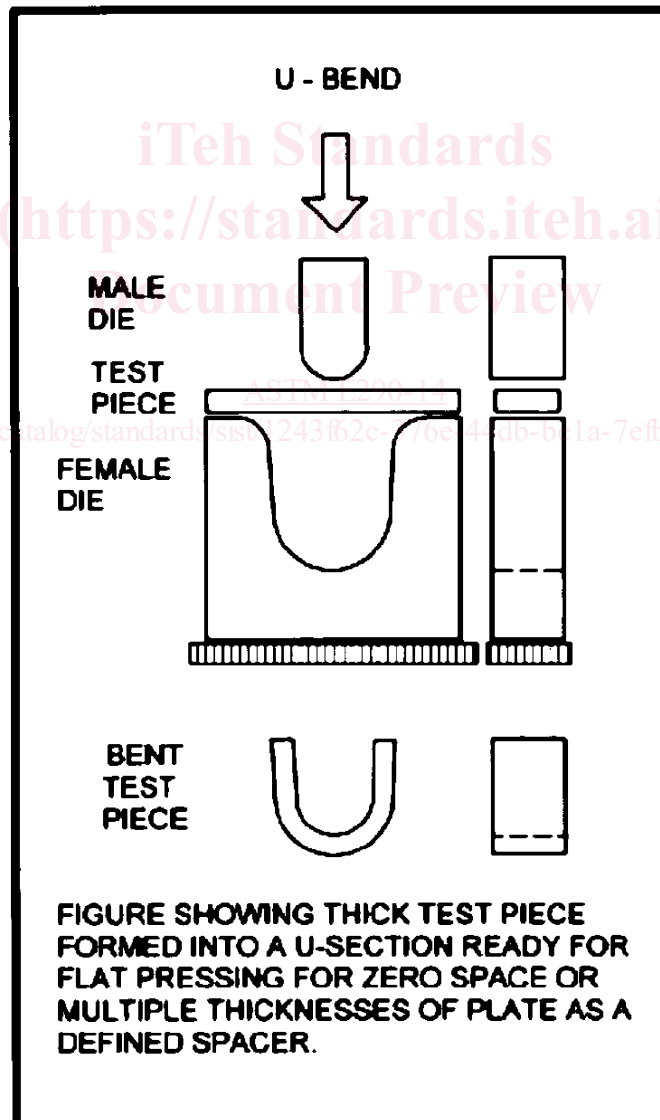

FIG. 4 Schematic Fixture for the Guided Bend, U-bend Test

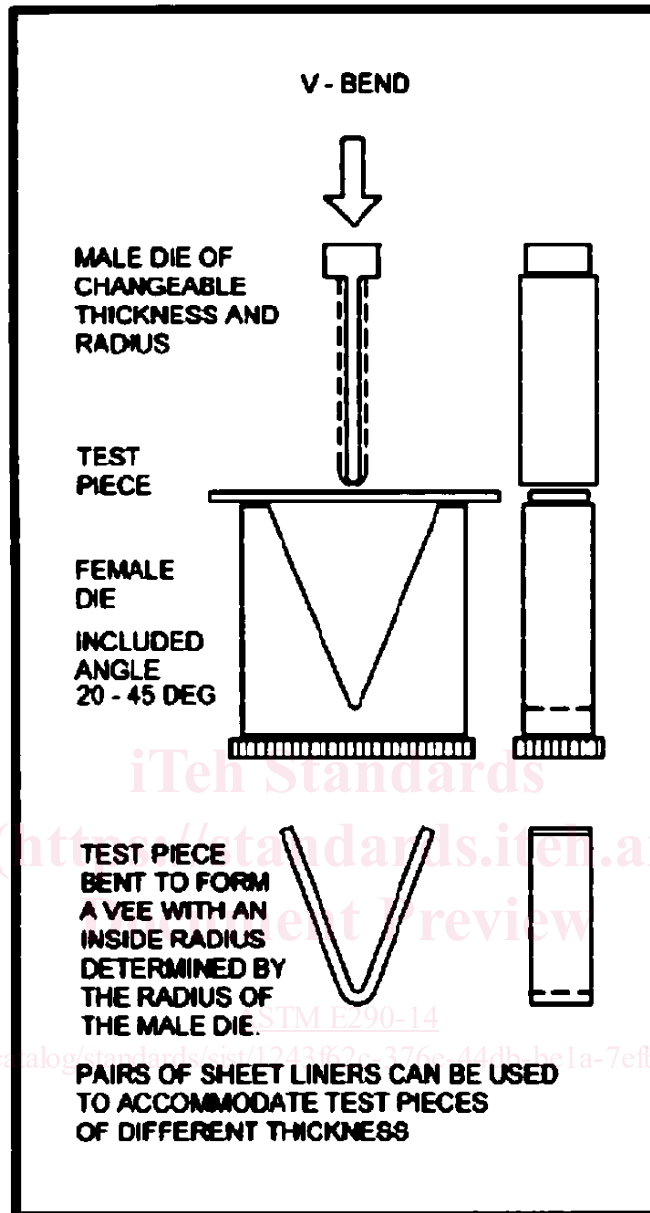

FIG. 5 Schematic Fixture for the Guided Bend, V- Bend Test

3.8.7 After completing the free-bend, the surface is examined for cracks and imperfections.

3.9 *Bend and Flatten*—For the bend and flatten test for ductility, an initial 180° bend is made as described in 3.8.1 and 3.8.3. The specimen is then placed between two parallel platens extending beyond the bent portion of the specimen and wider than the specimen width.

3.9.1 Force is exerted to clamp the specimen and cause the two legs to contact at the bend, exclusive of the eye of the bend (as shown schematically in Fig. 14).

3.9.2 Examination for cracks in the outer surface of the bend is done after removing the specimen from the bending force and allowing springback. The allowed number and size of cracks on the outer surface of the bend shall be as specified in the product standard.

3.9.3 Any surface imperfections resulting from the bend test shall be noted and reported.

4. Significance and Use

4.1 Bend tests for ductility provide a simple way to evaluate the quality of materials by their ability to resist cracking or other surface irregularities during one continuous bend. No reversal of the bend force shall be employed when conducting these tests.

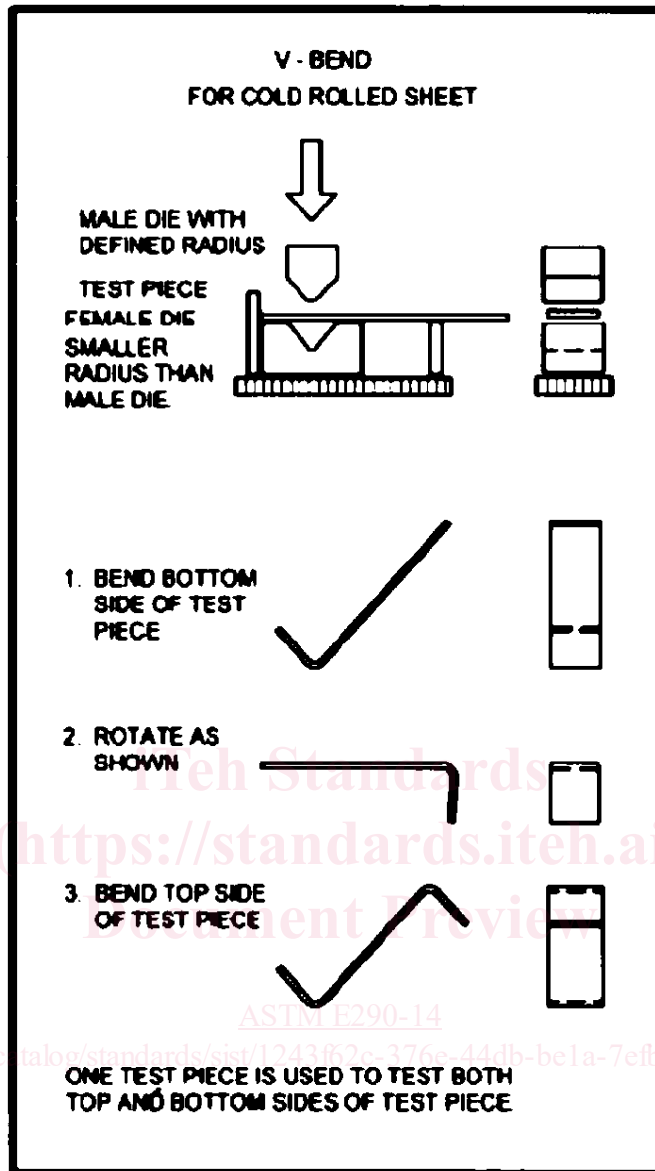

FIG. 6 Schematic Fixture for the Guided Bend, V- Bend Test for Cold Rolled Sheet

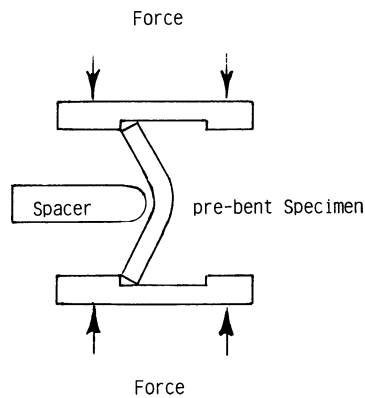

FIG. 7 Schematic Fixture for Completing the Guided-Bend Test Started as Shown in Fig. 3

4.2 The type of bend test used determines the location of the forces and constraints on the bent portion of the specimen, ranging from no direct contact to continuous contact.