



Standard Specification for Eye Protectors for Selected Sports¹

This standard is issued under the fixed designation F803; the number immediately following the designation indicates the year of original adoption or, in the case of revision, the year of last revision. A number in parentheses indicates the year of last reapproval. A superscript epsilon (ϵ) indicates an editorial change since the last revision or reapproval.

1. Scope

1.1 This specification covers eye protectors, designed for use by players of racket sports, women's lacrosse, field hockey, basketball, baseball, and soccer that minimize or significantly reduce injury to the eye and adnexa due to impact and penetration by racket-sport rackets and balls, women's lacrosse and field hockey sticks and balls, baseballs, soccer balls, hands, elbows, and fingers. Protective eyewear offers protection only to the eyes and does not protect other parts of the head.

1.2 Protectors are divided into three types depending on their design characteristics.

1.3 This specification applies to eye protectors for use by wearers of corrective lenses and also by those players who do not require prescription eyewear. (**Warning**—Polycarbonate or Trivex spectacle lenses should be used if spectacles are worn under protective eyewear.)

1.4 In this standard, the use of the words “shall” or “must” indicates a mandatory requirement. The word “should” indicates a recommendation.

1.5 Failure of the product occurs when the protector is unable to meet the general, mechanical, and optical (if applicable) requirements of the standard.

1.6 The values stated in SI units are to be regarded as the standard. The values given in parentheses are for information only. Metric units of measurement in this specification are in accordance with the International System of Units (SI). If a value for measurement as given in this specification is followed by an equivalent value in other units, the first stated is to be regarded as the requirement. A given equivalent value may be approximate.

1.7 The following precautionary caveat pertains only to the test methods portions, Sections 9 – 11, of this specification: *This standard does not purport to address all of the safety concerns, if any, associated with its use. It is the responsibility of the user of this standard to establish appropriate safety and*

health practices and determine the applicability of regulatory limitations prior to use.

2. Referenced Documents

2.1 *ASTM Standards*:²

D1003 Test Method for Haze and Luminous Transmittance of Transparent Plastics

F1776 Specification for Eye Protective Devices for Paintball Sports

2.2 *American National Standards*:³

ANSI Z80.1 Requirements for First-Quality Prescription Ophthalmic Lenses

ANSI Z80.3 Requirements for Nonprescription Sunglasses and Fashion Eyewear

ANSI Z87.1 Practice for Occupational and Educational Eye and Face Protectors

2.3 *Federal Standard*:

National Institute of Standards and Technology Special Technical Publication 374 Method for Determining the Resolving Power of Photographic Lenses (1973)⁴

2.4 *Canadian National Standard*:⁵

CAN/CSA-Z262.6 Specifications for facially featured head-forms

3. Terminology

3.1 *Definitions of Terms Specific to This Standard*:

3.1.1 *binocular, adj*—relating to the field of view which is shared by both eyes simultaneously; also any simultaneous activity of the two eyes.

3.1.2 *central viewing zone, n*—that part of the eye of a protector, which has its center in line with the wearer's normal line of sight. The zone is circular in shape, and 40 mm in diameter. The center of the central viewing zone shall be the

¹ This specification is under the jurisdiction of ASTM Committee F08 on Sports Equipment, Playing Surfaces, and Facilities and is the direct responsibility of Subcommittee F08.57 on Eye Safety for Sports.

Current edition approved June 1, 2014. Published September 2014. Originally approved in 1983. Last previous edition approved in 2011 as F803 – 11. DOI: 10.1520/F0803-14.

² For referenced ASTM standards, visit the ASTM website, www.astm.org, or contact ASTM Customer Service at service@astm.org. For *Annual Book of ASTM Standards* volume information, refer to the standard's Document Summary page on the ASTM website.

³ Available from American National Standards Institute (ANSI), 25 W. 43rd St., 4th Floor, New York, NY 10036.

⁴ Available from National Institute of Standards and Technology (NIST), 100 Bureau Dr., Stop 3460, Gaithersburg, MD 20899-3460.

⁵ Available from Canadian Standards Association (CSA), 5060 Spectrum Way, Mississauga, ON L4W 5N6, Canada, <http://www.csa.ca>.

point of intersection of the line of sight with the lens as mounted on the CSA headform.⁶

3.1.3 *cleanable, n*—the ability of a protective device to be made readily free of dirt or grime without being damaged during an appropriate cleaning process, such as the use of soap and water.

3.1.4 *coverage, n*—a characteristic of a protective device that obstructs straight line paths that are coincident with the wearer's eyes.

3.1.5 *definition (optical), n*—the characteristic of a lens that allows separate distinct points in close proximity to be discerned when looking through the lens.

3.1.6 *eye, n*—relating to the eye of a test headform or the eye of a person wearing a protector or that part of an eye protective device through which a wearer's eye would normally look.

3.1.7 *eye of the headform, n*—all structures contained within the orbital rim of the CSA headform.⁶

3.1.8 *fracture, n*—separation, as a result of impact, of any part of a protector resulting either in two completely separate pieces or the separation of a protector or part of a protector, intended as a continuous single piece.

3.1.9 *haze, n*—the fraction of the total transmitted light from a normally incident beam which is not transmitted in a focused condition but scattered by inclusions or surface defects. Excessive haze will reduce contrast and visibility.

3.1.10 *impact resistance, n*—the ability of a device to afford protection from impact as required by this specification.

3.1.11 *lens, n*—when so equipped, the transparent part or parts of a protective device through which the wearer normally sees.

3.1.12 *luminous transmittance, n*—luminous transmittance is a function of the spectral transmittance of the lens weighted by the corresponding ordinates of the photopic luminous efficiency distribution of the CIE (1931) standard colorimetric observer and by the spectral intensity of standard Illuminant C. (See ANSI Z80.3, 1986, Paragraph 3.9.1.)

3.1.13 *normal lines of sight, n*—straight ahead horizontal lines that intersect the center of the eyes of the appropriate headform.

3.1.14 *penetration resistance, n*—the ability of a device to afford protection from moving objects as required by this specification.

3.1.15 *permanent, adj*—marked so as not to become unidentifiable with normal usage.

3.1.16 *power imbalance, adj*—relates to the condition in which the refractive power of the lens or lenses of a protector is different as presented to the two eyes.

3.1.17 *prism, n*—a prism bends a beam of light as a result of the lack of parallelism of the two surfaces of a lens through which the beam of light traverses. The amount of bending is a

function of the curvatures, thickness, index of refraction of the material and the angle of approach of the line of sight to the optical surface. In this specification, *prism* refers to the amount of bending that is imposed upon the line of sight of a wearer of an eye protector for the specified viewing position. Prism is expressed in diopters. The deviation of the line of sight by 1 cm/m is one prism diopter.

3.1.17.1 *base-in, n*—relating to the type of prism imbalance that tends to cause parallel rays of light passing through a protector, spaced apart by the interpupillary distance, to converge.

3.1.17.2 *base-out, n*—relating to the type of prism imbalance that tends to cause parallel rays of light passing through a protector, spaced apart by the interpupillary distance, to diverge.

3.1.17.3 *base-up*—refers to the type of prism that causes a horizontal beam of light to bend upward causing objects to appear lower than their true position.

3.1.17.4 *base-down*—refers to the type of prism that causes a horizontal beam of light to bend down causing objects to appear higher than their true position.

3.1.18 *prism imbalance:*

3.1.18.1 *horizontal imbalance*—the difference in prismatic deviation of incident parallel light beams on the two eyes of a protective device in the horizontal meridian. (See *base-in* and *base-out*).

3.1.18.2 *vertical imbalance*—the difference in prismatic deviation between parallel light beams incident on the two eyes of a protective device in the vertical meridian.

3.1.19 *protective device (or protector), n*—a device that provides protection to the wearer's eye against specific hazards encountered in sports.

3.1.20 *refractive power, n*—the focusing effect of a lens expressed in diopters.

3.1.20.1 *astigmatism, n*—a condition in a lens that creates two axially separated line foci of each object point, the lines being mutually perpendicular. In other words, the lens has two different refractive powers in meridians that are 90° apart.

3.1.21 *scotoma, n*—a blind or partially blind area within the visual field.

3.1.22 *spherical power, n*—the average of the maximum meridional astigmatic power and the minimum meridional astigmatic power of a lens.

4. Classification

4.1 Eye protectors are classified into the following types:

4.1.1 *Type I*—A protector with the lens or lenses and frame frontpiece molded as one unit. Frame temples or other devices, such as straps, to affix the lens/frontpiece may be separate pieces.

4.1.2 *Type II*—A protector with a single lens or lenses, either plano or prescription, mounted in a frame that was manufactured as a separate unit.

4.1.3 *Type III*—A protector without a lens.

4.1.4 *Type IV*—A full or partial face shield.

⁶ Available from Canadian Standards Association (CSA), 178 Rexdale Blvd., Toronto, ON Canada M9W1R3.

5. General Requirements

5.1 *Materials of Construction:*

5.1.1 The manufacturer's choice of material shall be in accordance with 5.1.2 and 5.1.3.

5.1.2 Materials coming into contact with the wearer's face shall not be of a type known to cause skin irritation.

5.1.3 Materials coming into contact with the wearer's face, except replaceable padding, shall not undergo significant loss of strength or flexibility, or other physical change as a result of perspiration, oil, or grease from the wearer's skin and hair.

5.1.3.1 Manufacturer will provide material selection by an affidavit submitted to the test agency which supports sections 5.1.1 – 5.1.3.

5.1.4 *Cleanability*—Protective devices shall be capable of being cleaned to the degree that when conditioned in accordance with the method described in 10.1, they shall remain functional in all ways.

5.2 *Finishes and Construction*—The protector shall be constructed in a manner to prevent the missile or components of the protector from contact with the eye of the headform when tested in accordance with Section 11.

5.3 Straps are not required on eye protectors, provided the protector passes the standard without straps.

6. Performance Requirements

6.1 *Optical Requirements—Type I and II Protectors:*

NOTE 1—Type IV protectors, full or partial face shields, shall conform to the optical requirements of Specification F1776.

6.1.1 *Refractive Tolerances*—When tested in accordance with 9.7, the spherical power shall be in the range of +0.06 diopters to -0.18 diopters.

6.1.2 *Astigmatism*—When tested in accordance with 9.6, the astigmatism shall not exceed 0.12 diopter.

6.1.3 *Power Imbalance*—When tested in accordance with 9.6, the power imbalance in corresponding meridians shall not exceed 0.18 diopters between the two eyes for straight-ahead seeing.

6.1.4 *Prism*—For the primary viewing position of either eye of a shield or pair of lenses, the prism deviation shall not exceed 0.50 prism diopters when tested in accordance with 9.4.

6.1.5 *Prism Imbalance:*

6.1.5.1 *Vertical and Base-In*—0.25 prism diopters.

6.1.5.2 *Base-Out*—0.50 prism diopters.

6.1.6 *Luminous Transmittance*—When tested in accordance with 9.3, protectors shall have a luminous transmittance of not less than 85 % for a clear device and not less than 20 % for tinted devices. Additionally, the difference in values as would be viewed by the two eyes through a single protector as worn shall not exceed 0.9 to 1.1 times the other value (measured at the design line of sight) unless specifically prescribed by an ophthalmic professional.

6.1.7 *Ultraviolet Transmittance*—When tested in accordance with 9.3, protectors shall meet the UV A and UV B requirements set forth in ANSI Z80.3.

6.1.8 *Haze*—When tested in accordance with 9.5, the haze in the protector shall not exceed 3 %.

6.1.9 Lenses that exhibit any distortion or doubling of the image during the test for refractive power or prism shall be further tested in accordance with 9.2.

6.1.10 *Optical Quality*—Within the central viewing zone, striae warpage, surface ripples, lenticulations, or abrupt optical changes that are visible under the test conditions of 9.2 and that would impair the function of the lens shall be cause for rejection. Visual impairment is defined by the scanning and focimeter test of 9.2.

6.1.11 *Surface and Internal Defects*—Pits, scratches, bubbles, grayness, specks, cracks, and water marks that are visible under the test conditions of 9.7 and that would impair the function of the lens shall be a cause for rejection. Grayness should be evaluated by the requirements of 6.1.6.

6.2 *Mechanical Requirements:*

6.2.1 No contact with the eye of the headform shall be permitted when tested in accordance with Section 11.

6.2.2 When tested in accordance with Section 11, displaced fragments or complete fracture of the frame or lenses constitutes a failure.

6.2.3 When tested in accordance with Section 11, any displacement of the lens from the frame constitutes a failure.

6.2.4 A protector that is dislodged from the test headform when tested in accordance with Section 11 shall not constitute a failure, provided all of the above mechanical requirements are met.

6.3 *Requirements for Frames to be Fitted with Rx (corrective) Lenses.:*

6.3.1 Frames intended to be used for prescription lenses shall be tested to the requirements of 6.2 with plano, highest plus sphere power and lowest minus sphere power as desired to be qualified by the manufacturer. Each lens material(s)/manufacturer(s), surface treatment (for example, coating) and finishing process as desired to be qualified for laboratory finishing. If all test lenses pass, than any prescription lens of the same of greater thickness at it thinnest point within the prescription range tested and qualified which is made of the same material(s)/manufacturer(s), with the same surface treatment (coatings) and finishing processes may be approved for use with that frame.

6.3.2 Optical Finishing laboratories shall only fit lenses into protector frames within the highest plus and lowest minus sphere power as qualified for the frame in accord with the minimum thickness, material(s), manufacturer(s) and surface treatment(s) which were qualified and approved for use with the protector (frame) in accordance with lenses glazed into frames shall be within the demonstrated diopter which the frame was qualified for.

6.3.3 Finished (glazed) lenses shall comply with current requirements as set forth in ANSI Z80.1.

7. Sample Preparation

7.1 Only new and complete eye protectors as offered for retail sale shall be tested.

7.2 Protectors shall be conditioned and tested at $23 \pm 2^\circ\text{C}$ and $50 \pm 5\%$ relative humidity for a minimum period of 4 h prior to the test.

8. Product Marking

8.1 All eye protectors shall bear the following permanent markings (Type II protectors with plano lenses must be labeled on both frame and lens. Type II protectors with Rx lenses shall be provided with documentation consisting of: copy of the Rx, lens material type, and dispensing or finishing laboratory, or both, name and address):

8.1.1 Manufacturer's identity,

8.1.2 Eye protector model identity, and

8.2 A label or tag bearing the following information shall be securely attached to, or accompany, each eye protector at time of sale:

8.2.1 Month and year of manufacture.

8.2.2 Clear and prominent markings providing sizing guidance—that is, gender, age, or size (small, medium, large), or a combination thereof.

8.2.3 A warning stating which cleaning and antifog agents may be used with eye protectors incorporating clear plastic shields and further stating that the lenses should be replaced when scratches become troublesome, or if cracks appear at the edges;

8.2.4 A warning stating that if the eye protector is severely impacted then the degree of protection provided may be reduced and the eye protector must be replaced. Failure to do so may result in permanent injuries to the eye; and

8.2.5 A warning stating that if a lens pops out due to impact during play, the wearer should stop playing and have the protector replaced.

8.2.6 A warning statement that if the eye protector is stored at cold temperatures it should be allowed to return to room temperature before use.

8.2.7 A clear statement shall define the sports for which the protector is designed. (For example, this eye protector has been tested and is in compliance with Specification F803 (for stipulate sports).)

8.2.8 For products designed for baseball or women's lacrosse, or both, the speed and age bracket which the protector satisfies compliance guidelines.

8.2.9 Frames intended to be fitted with Rx (corrective) lenses shall be provided (by the frame manufacturer) with instructions to the optical finishing laboratory which specify (at minimum): minimum lens thickness, the highest plus and lowest minus sphere power range, detailed specifications on the required bevel design or mounting technique, approved lens material(s)/manufacturer(s) and associated surface treatments and finishing processes allowable to be used with the frame.

TEST METHODS

9. Optical Tests

9.1 *Field of View (Angle of Vision):*

9.1.1 *Purpose*—Field of view requirements are not required. Any sighting method may be used to determine the unobstructed angle visually available to the user. Alternate test methods are included in [Appendix X2](#) and [Appendix X3](#).

9.2 *Optical Quality*—Localized power errors or aberrations that are detected by the visual inspection procedure of [9.2.1](#) are

permissible if no measurable or gross focimeter or telescope target distortion or blur is found when the localized area is examined with an instrument as indicated in [9.2.2](#).

9.2.1 *Inspection Procedure*—One method of optical inspection is to view a high-contrast grid pattern of dark and white lines through the lens, scanning it area by area and moving it about. The grid pattern should be at least 18 by 18 in. and constructed of high contrast black lines on a white background (the white separations being equal to the black lines, both being approximately ¼ in. wide). The target should be at least 6 to 8 ft from the observer, and the lens should be held at least 18 to 24 in. from the eye. Any ripples in the lens detected by this test method should be further examined in accordance with [9.2.2](#).

9.2.2 The referee method of detecting optical defects and local aberrations is to scan the central viewing zone, especially areas of suspicion arising from the visual test of [9.2.1](#). The lens or shield should be scanned with a precision focimeter or an 8× to 10× telescope using the targets and arrangements described in [9.6.2](#) to [9.6.2.5](#). The aperture should be 5 to 7 mm for this examination. Areas outside the central viewing zone or within 6 mm of the edge need not be tested. When the central viewing area is scanned, there shall be no sudden jump, doubling, or blurring of the image greater than 0.08 diopters change in power. Gradual variations in the central viewing zone shall be within the power imbalance tolerances. An optical focimeter with electronic readout repeatable to 0.02 diopters is a satisfactory alternate method. These scanning procedures may be made by scanning across the lens surface not necessarily in the “as worn” mode.

9.3 *Luminous Transmittance*—Use a suitable photometer, such as a Gardner Hazemeter, or other device comprised of a light source of CIE Illuminant A at 2856°K color temperature, and a photometric probe and meter capable of reading transmission in percent over a range of 1 % to 100. Use a suitable enclosure to block against stray light and contain the test samples. Following the manufacturers instructions for the use of the instrument, measure the specimen for percent transmittance within each of the two central viewing zones. The measured values shall meet the established criteria for the device. A spectrophotometer, followed by appropriate photometric calculation, may also be used.

9.3.1 For the purposes of this specification, luminance transmittance may be measured with inexpensive photometers.⁷ A fixturing device should be devised to exclude ambient light. The source need not be strictly Illuminant C. A tungsten lamp or a screw-in fluorescent lamp provides adequate simulation of the use environment.

9.3.2 *Ultraviolet Transmittance*—Average transmittances are measured in no greater than 10 nm band widths with a commercially available spectrophotometer.

9.4 *Prismatic Deviation Measurements:*

9.4.1 *Purpose*—The test presented here is intended to measure the angular deviation of light rays created by the protective device as they pass through the lens(es).

⁷ Inexpensive photometers, available from Edmund Scientific Corp., have been found satisfactory for this purpose.

9.4.2 *Apparatus*—A telescope, equipped with a cross hair reticule having a magnification of 8× to 10× and an aperture 19 mm in diameter shall be used. The test method outlined in ANSI Z87.1-1989 has been found satisfactory for this purpose. Other methods that yield comparable results may be used. For this test method the target distance is 4 m. This is easier to achieve than longer distances. The target can be metric graph paper divided into 1 cm and 5 mm squares or constructed with a ruler and compass. A circle with a 2 cm radius and a center dot about 1.5 mm in diameter will provide the tolerance for overall prism in one eye. If the 1 cm and 5 mm grids are darkened for 20 mm in each direction from center, with the center lines emphasized, measurements will be easier. Each 5 mm of the scale represents 0.125 prism diopters. The prism values off-center can be labeled along one edge of the 4 cm square vertically and horizontally departing from the central zero. The right side of the target should be labeled plus (+) and the left side minus (−) and vertical top plus (+) and bottom minus (−).

9.4.3 *Test Procedure*—The eye protector shall be mounted in a fixture so that the axis of the test instrument is aligned with the normal line of sight as defined in 3.1.13. An appropriate standard head with parallel horizontal holes drilled through the eyes would be convenient, but in some cases unnecessary. A fixture with a board and dowel sticks can be devised to reproduce the alignment observer on a standard head. The interpupillary distance must match that of head. The fixture or head should be mounted on a bench or table. A single telescope can be used for straight ahead monocular readings. The fixture for holding the protector can be slotted to move from one eye to the other through the proper interpupillary distance. The telescope should be focused on the target at 4 m and aligned carefully with the cross hairs on the zero point of the target. A two-meridian screw adjustment will help. The readings for the vertical and horizontal prism for both eyes must be recorded. The monocular prism test is achieved by noting whether the cross hairs remain in the 20-mm circle. Each 5 mm equals 0.125 prism diopters. For the prism imbalance test, readings in prism diopters for each eye must be taken. This is done by recording the amount and direction of displacement of the cross hairs on the target. Apparent movement of the cross hairs in the plus direction is base-out for the right eye and base-in for the left eye whether or not reversed by the telescope. The same is true for vertical measurements. Record the apparent position of the cross hairs on the target with plus and minus signs, in terms of prism diopters. Subtract the left eye readings from the right eye readings. For vertical prism imbalance the absolute value of the resulting figure is the imbalance. For horizontal prism imbalance, a net positive value indicates the base-out prism imbalance. A net negative value indicates base-in prism imbalance.

9.4.3.1 *Alternate Prism Tests (see 9.8.1)*—Tabletop systems with a 1 m sample-to-target distance are also acceptable. The target dimensions should be one-fourth of those given in 9.4.2.

9.5 Haze:

9.5.1 Measure the protector for percent haze within the central viewing zones, with the protector rotated so that the passing beam of light is as perpendicular to the testing surface

as is practicable, in accordance with the requirements of Test Method D1003. The measured values shall meet the established criteria for the device.

9.5.2 Haze may also be determined with a commercially available Gardner Hazemeter.

9.6 Refractive Power Measurements:

9.6.1 *Purpose*—The test method presented here is intended to measure spherical and cylindrical refractive power induced by the protective device.

9.6.2 *Apparatus*—An 8 power telescope with an effective aperture of 19 mm shall be used in conjunction with an illuminated target located a distance of 10.67 m from the telescope objective. The focus adjustment of the telescope shall be calibrated in at least 0.01 diopter increments. The test target shall be that specified by ANSI Z87.1-1989, Section 15.4.

9.6.3 Test Procedure:

9.6.3.1 Adjust the telescope by setting the calibrated focus adjustment to zero power, then adjust the eyepiece so that the test target is clearly resolved without the protective device in front of the telescope. The quality of the telescope and the observer's vision should be such that Pattern 40 of the High Contrast Test Chart of National Institute of Standards and Technology Special Publication 374 is clearly resolved.

9.6.3.2 Mount the protective device in front of the telescope such that the telescope axis passes through either one of the central viewing zones. The angular orientation of the protector should be the same as used for prismatic deviation measurements. Take refractive power measurements for both central viewing zones.

9.6.3.3 Focus the telescope in the radial lines of the test target until they appear as sharp as possible. Two possibilities may occur.

9.6.3.4 If all radial lines appear equally well focused (sharp) at the same telescope power setting, the eye protective device has no measurable astigmatism and the power reading of the telescope at that position is the spherical refractive power of the protector lens.

9.6.4 Measure the maximum meridional power for each eye, recording the extremes, the most plus readings, and the most negative readings. There will therefore be four readings. If any are more plus than 0.12 or more minus than −0.25, the power test fails. Also, if any of the readings are more than 0.12 diopters apart the product is failed for either astigmatism or power imbalance. If the widely spaced errors are on one lens, it is astigmatism.

9.6.5 Alternate methods of measuring refractive power and astigmatism, such as focimeters, visual, and electronic, may be used. Custom optical bench systems are acceptable provided it can be demonstrated that the precision and bias are at least equivalent to the telescope method described in 9.6.3.

9.7 Surface Imperfections and Internal Defects:

9.7.1 Inspect lenses in a lighted room without the aid of magnifying devices.

9.7.2 View lenses against a dark background in the light from an open-shaded 40 W incandescent clear lamp with the lens positioned approximately 305 mm (12 in.) from the light source.

9.7.3 *Visual Function Impairment*—Impairment of the function of the lens may be determined by testing the lens in the “as worn” position before a trained inspector’s eye. Impairment is present if the defects are detected against either light or dark plain backgrounds, with side illumination on the lens for the dark background test.

9.8 *Alternate Optical Tests:*

9.8.1 *Alternate Prism Test:*

9.8.1.1 The target of 9.4.2 (1 cm graph paper subdivided into at least 5 mm squares) is modified as follows: Mark a center point with a black dot not over 1.5 mm in diameter. For a total prism tolerance of 0.50 prism diopters, draw a circle with a 20 mm radius about this center. For vertical prism imbalance tests draw horizontal lines 1 cm above and below center. For a base-in tolerance draw a vertical line 10 mm to the left of center and for base-out tolerance draw a line 40 mm to the right of center. This target is for use with mirrors and a beam splitter so that both eyes are tested simultaneously. The target for the left eye will be best seen if on black matte paper. The center *x* can be marked with a red pen. The 20 mm radius circle should also be red. No other lines are necessary.

9.8.1.2 The two targets should be mounted laterally and separated by 64 mm. The left eye target should be mounted on a wooden block or cardboard box so that it is 64 mm closer to

the telescope than the right eye target. The set up (see Fig. 1) requires as a beam splitter and a 45° mirror between the telescope and the test sample. The mirror and beam splitter must be carefully adjusted and the telescope carefully focused for the 4 m distance. Optical bench equipment will facilitate the adjustments. Thin metal shims on the back of the mirror will help. When adjusted properly, the black and red centers as well as the circles should be superimposed and the cross hairs of the telescope should be on both centers at the same time.

9.8.1.3 To test a sample, mount the lens or lenses as shown in Fig. 1. The right eye line-of-sight goes through the beam splitter and the left eye line-of-sight goes through the mirror. The cross hairs should lie within both circles. If they do not, then one or both eyes have more than 0.5 prism diopters.

9.8.1.4 For prism imbalance, the red dot of the left eye should lie in the rectangle marked out for the right eye. If it does not, then there is excess prism imbalance.

10. **Cleaning**

10.1 Follow the manufacturer’s instructions for cleaning. If none are available, clean with mild soap and warm water solution by soaking the device in the soap solution maintained at 140°F for 10 min. Rinse thoroughly and allow to air dry. Any

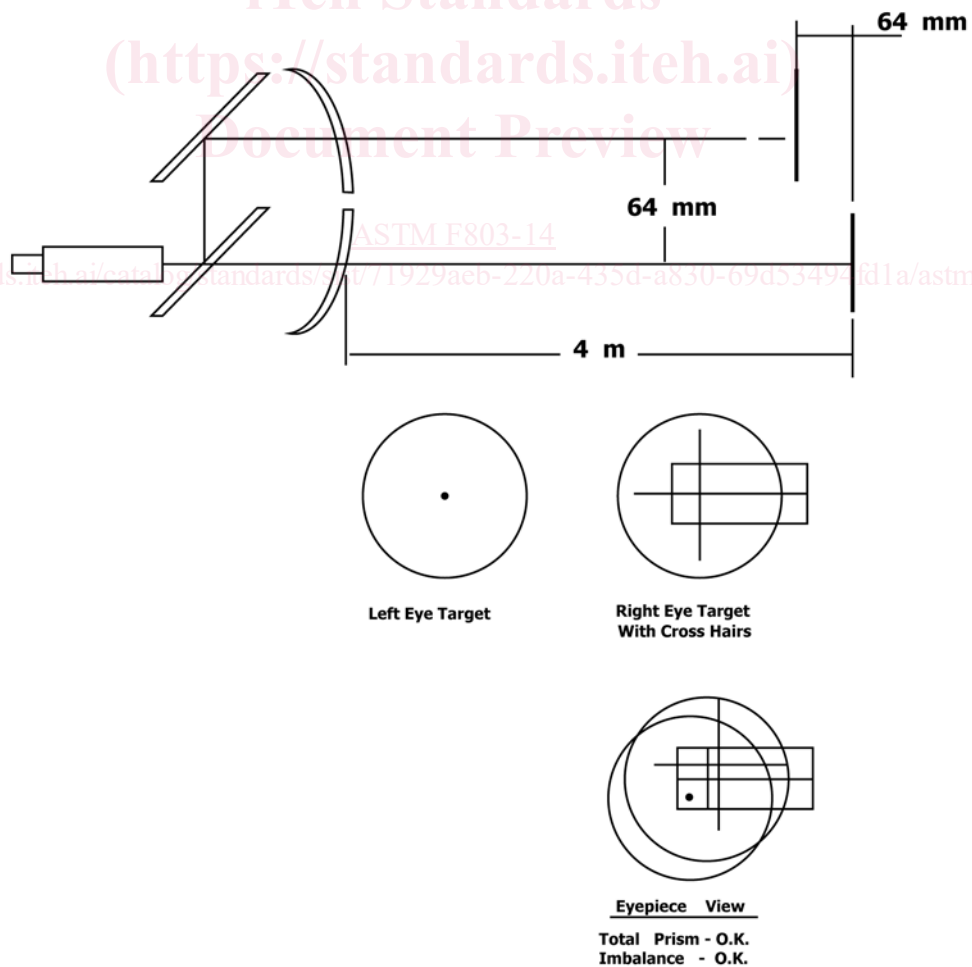

FIG. 1 Alternate Prism Test Set-Up (See 9.8.1)