



SLOVENSKI STANDARD
SIST ISO 3506-1:2000
01-januar-2000

A Y Ubg_Y`Uglbcghj_cfcnj^g_c`cXdcfb] `bYf`Uj b] `^Y_Y`!`%`XY.`Gcfb]_žj]U_]]b
nUj]

Mechanical properties of corrosion-resistant stainless steel fasteners -- Part 1: Bolts, screws and studs

iTeh STANDARD PREVIEW

Caractéristiques mécaniques des éléments de fixation en acier inoxydable résistant à la corrosion -- Partie 1: Vis et goujons

[SIST ISO 3506-1:2000](https://standards.itih.ai/catalog/standards/sist/8a2455d6-508e-4bd7-99a9-cf97ac5de0ae/sist-iso-3506-1-2000)

Ta slovenski standard je istoveten z: **ISO 3506-1:1997**

ICS:

21.060.10 Sorniki, vijaki, stebelni vijaki Bolts, screws, studs

SIST ISO 3506-1:2000

en

iTeh STANDARD PREVIEW
(standards.iteh.ai)

SIST ISO 3506-1:2000

<https://standards.iteh.ai/catalog/standards/sist/8a2455d6-508e-4bd7-99a9-e197ae3de0ae/sist-iso-3506-1-2000>

INTERNATIONAL
STANDARD

ISO
3506-1

First edition
1997-12-01

**Mechanical properties of corrosion-
resistant stainless-steel fasteners —**

Part 1:
Bolts, screws and studs

*Caractéristiques mécaniques des éléments de fixation en acier inoxydable
résistant à la corrosion —*

Partie 1: Vis et goujons

iTeh STANDARD PREVIEW
(standards.iteh.ai)

[SIST ISO 3506-1:2000](https://standards.iteh.ai/catalog/standards/sist/8a2455d6-508e-4bd7-99a9-e197ae3de0ae/sist-iso-3506-1-2000)

[https://standards.iteh.ai/catalog/standards/sist/8a2455d6-508e-4bd7-99a9-
e197ae3de0ae/sist-iso-3506-1-2000](https://standards.iteh.ai/catalog/standards/sist/8a2455d6-508e-4bd7-99a9-e197ae3de0ae/sist-iso-3506-1-2000)



Reference number
ISO 3506-1:1997(E)

Foreword

ISO (the International Organization for Standardization) is a worldwide federation of national standards bodies (ISO member bodies). The work of preparing International Standards is normally carried out through ISO technical committees. Each member body interested in a subject for which a technical committee has been established has the right to be represented on that committee. International organizations, governmental and non-governmental, in liaison with ISO, also take part in the work. ISO collaborates closely with the International Electrotechnical Commission (IEC) on all matters of electrotechnical standardization.

Draft International Standards adopted by the technical committees are circulated to the member bodies for voting. Publication as an International Standard requires approval by at least 75 % of the member bodies casting a vote.

International Standard ISO 3506-1 was prepared by Technical Committee ISO/TC 2, *Fasteners*, Sub-Committee SC 1, *Mechanical properties of fasteners*.

This first edition, together with ISO 3506-2 and ISO 3506-3, cancels and replaces ISO 3506:1979, which has been technically revised.

ISO 3506 consists of the following parts, under the general title *Mechanical properties of corrosion-resistant stainless-steel fasteners*.

- *Part 1: Bolts, screws and studs*
- *Part 2: Nuts*
- *Part 3: Set screws and similar fasteners not under tensile stress*

Annex A forms an integral part of this part of ISO 3506. Annexes B to I are for information only.

© ISO 1997

All rights reserved. Unless otherwise specified, no part of this publication may be reproduced or utilized in any form or by any means, electronic or mechanical, including photocopying and microfilm, without permission in writing from the publisher.

International Organization for Standardization
Case postale 56 • CH-1211 Genève 20 • Switzerland
Internet central@iso.ch
X.400 c=ch; a=400net; p=iso; o=isocs; s=central

Printed in Switzerland

Introduction

In the preparation of this part of ISO 3506 special attention has been given to the fundamentally different property characteristics of the stainless steel fastener grades compared with those of carbon steel and low-alloy steel fasteners. Ferritic and austenitic stainless steels are strengthened only by cold working and consequently the components do not have as homogeneous a condition as hardened and tempered parts. These special features have been recognized in the elaboration of the property classes and the test procedures for mechanical properties. The latter differ from the carbon steel and low-alloy steel fastener test procedures with regard to the measurement of the stress at 0,2 % permanent strain (yield stress) and ductility (total extension after fracture).

iTeh STANDARD PREVIEW (standards.iteh.ai)

[SIST ISO 3506-1:2000](https://standards.iteh.ai/catalog/standards/sist/8a2455d6-508e-4bd7-99a9-e197ae3de0ae/sist-iso-3506-1-2000)

<https://standards.iteh.ai/catalog/standards/sist/8a2455d6-508e-4bd7-99a9-e197ae3de0ae/sist-iso-3506-1-2000>

iTeh STANDARD PREVIEW
This page intentionally left blank
(standards.iteh.ai)

SIST ISO 3506-1:2000

<https://standards.iteh.ai/catalog/standards/sist/8a2455d6-508e-4bd7-99a9-e197ae3de0ae/sist-iso-3506-1-2000>

Mechanical properties of corrosion-resistant stainless-steel fasteners —

Part 1:

Bolts, screws and studs

1 Scope

This part of ISO 3506 specifies the mechanical properties of bolts, screws and studs made of austenitic, martensitic and ferritic grades of corrosion-resistant stainless steels when tested over an ambient temperature range of 15 °C to 25 °C. Properties will vary at higher or lower temperatures.

It applies to bolts, screws and studs

- with nominal thread diameter (d) up to and including 39 mm;
- of triangular ISO metric threads with diameters and pitches in accordance with ISO 68-1, ISO 261 and ISO 262;
- of any shape.

It does not apply to screws with special properties such as weldability.

This part of ISO 3506 does not define corrosion or oxidation resistance in particular environments, however some information on materials for particular environments is given in annex E. Regarding definitions of corrosion and corrosion resistance see ISO 8044.

The aim of this part of ISO 3506 is a classification into property classes of corrosion resistant stainless steel fasteners. Some materials can be used at temperatures down to – 200 °C, some can be used at temperatures up to + 800 °C in air. Information on the influence of temperature on mechanical properties is found in annex F.

Corrosion and oxidation performances and mechanical properties for use at elevated or sub-zero temperatures must be the subject of agreement between user and manufacturer in each particular case. Annex G shows how the risk of intergranular corrosion at elevated temperatures depends on the carbon content.

All austenitic stainless steel fasteners are normally non-magnetic in the annealed condition; after cold working, some magnetic properties may be evident (see annex H).

2 Normative references

The following standards contain provisions which, through reference in this text, constitute provisions of this part of ISO 3506. At the time of publication, the editions indicated were valid. All standards are subject to revision, and parties to agreements based on this part of ISO 3506 are encouraged to investigate the possibility of applying the most recent editions of the normative documents indicated below. Members of IEC and ISO maintain registers of currently valid International Standards.

ISO 68-1:—¹⁾, *ISO general purpose screw threads – Basic profile – Part 1: Metric screw threads.*

ISO 261:—²⁾, *ISO general purpose metric screw threads – General plan.*

1) To be published. (Revision of ISO 68:1973)

2) To be published. (Revision of ISO 261:1973)

ISO 262:—³⁾, *ISO general purpose metric screw threads – Selected sizes for screws, bolts and nuts.*

ISO 724:1993, *ISO general purpose metric screw threads – Basic dimensions.*

ISO 898-1:—⁴⁾, *Mechanical properties of fasteners made of carbon steel and alloy steel – Part 1: Bolts, screws and studs.*

ISO 3651-1:—⁵⁾, *Determination of resistance to intergranular corrosion stainless steels – Part 1: Austenitic and ferritic-austenitic (duplex) stainless steels – Corrosion test in nitric acid medium by measurement of loss in mass (Huey test).*

ISO 3651-2:—⁶⁾, *Determination of resistance to intergranular corrosion stainless steels – Part 2: Ferritic, austenitic and ferritic-austenitic (duplex) stainless steels – Corrosion test in media containing sulfuric acid.*

ISO 6506:1981, *Metallic materials – Hardness test – Brinell test.*

ISO 6507-1:1997, *Metallic materials – Hardness test – Vickers test – Part 1: Test method.*

ISO 6508:1986, *Metallic materials – Hardness test – Rockwell test (scales A – B – C – D – E – F – G – H – K).*

ISO 6892:—⁷⁾, *Metallic materials – Tensile testing at ambient temperature.*

ISO 8044:—⁸⁾, *Corrosion of metals and alloys – Basic terms and definitions.*

3 Designation, marking and finish

3.1 Designation

The designation system for stainless steel grades and property classes for bolts, screws and studs is shown in figure 1. The designation of the material consists of two blocks which are separated by a hyphen. The first block designates the steel grade, the second block the property class.

The designation of the steel grade (first block) consists of the letters

A for austenitic steel or

C for martensitic steel or

F for ferritic steel

which indicate the group of steel and a digit which indicates a range of chemical compositions within this steel group.

The designation of the property class (second block) consists of 2 digits which indicates 1/10 of the tensile strength of the fastener.

Examples:

1) **A2-70** indicates:

austenitic steel, cold worked, minimum 700 N/mm² (700 MPa) tensile strength.

2) **C4-70** indicates:

martensitic steel, hardened and tempered, minimum 700 N/mm² (700 MPa) tensile strength.

3) To be published. (Revision of ISO 262:1973)

4) To be published. (Revision of ISO 898-1:1988)

5) To be published. (Revision of ISO 3651-1:1976)

6) To be published. (Revision of ISO 3651-2:1976)

7) To be published. (Revision of ISO 6892:1984)

8) To be published. (Revision of ISO 8044:1988)

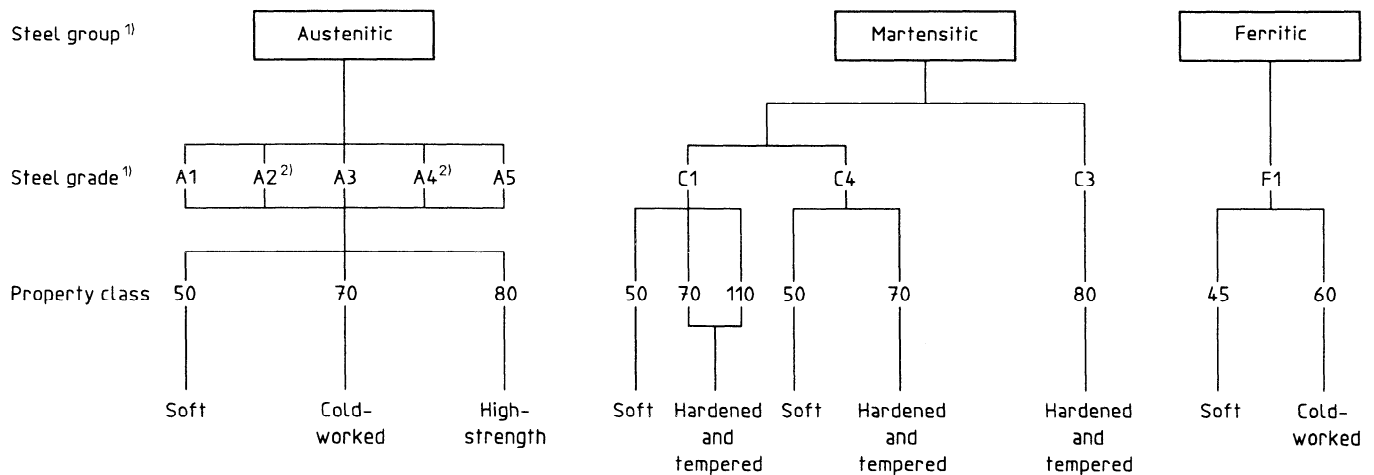

- 1) The steel groups and steel grades classified in figure 1 are described in annex B and specified by the chemical composition given in table 1.
- 2) Low carbon stainless steels with carbon content not exceeding 0,03 % may additionally be marked with an L.

Example: A4L – 80

Figure 1 — Designation system for stainless steel grades and property classes for bolts, screws and studs

3.2 Marking

iTeh STANDARD PREVIEW

Only if all requirements in this part of ISO 3506 are met, parts shall be marked and/or described according to the designation system described in 3.1.

SIST ISO 3506-1:2000

3.2.1 Bolts and screws

<https://standards.itih.ai/catalog/standards/sist/8a2455d6-508e-4bd7-99a9-e197ae3de0ae/sist-iso-3506-1-2000>

All hexagon head bolts and screws and hexagon or hexalobular socket head cap screws of nominal thread diameter $d \geq 5$ mm shall be clearly marked in accordance with 3.1, figure 1 and figure 2. The marking shall include the steel grade and property class and also the manufacturer's identification mark. Other types of bolts and screws can be marked in the same way, where it is possible to do so, and on the head portion only. Additional marking is allowed provided it does not cause confusion.

3.2.2 Studs

Studs of nominal thread diameter $d \geq 6$ mm shall be clearly marked in accordance with 3.1, figure 1 and figure 2. The marking shall be on the unthreaded part of the stud and shall contain the manufacturer's identification mark, steel grade and property class. If marking on the unthreaded portion is not possible, marking of steel grade only on the nut end of the stud is allowed, see figure 2.

3.2.3 Packages

Marking with the designation and manufacturer's identification mark is mandatory on all packages of all sizes.

3.3 Finish

Unless otherwise specified, fasteners in accordance with this part of ISO 3506 shall be supplied clean and bright. For maximum corrosion resistance passivation is recommended.

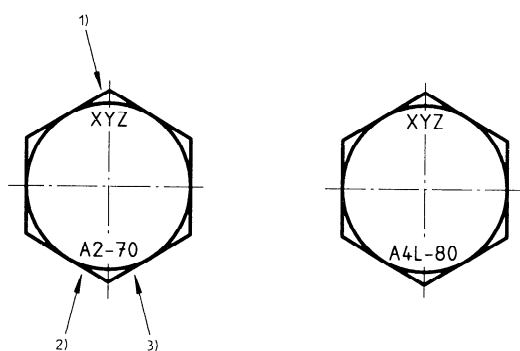

- 1) manufacturer's identification mark
- 2) steel grade
- 3) property class

Marking of hexagon head bolts and screws

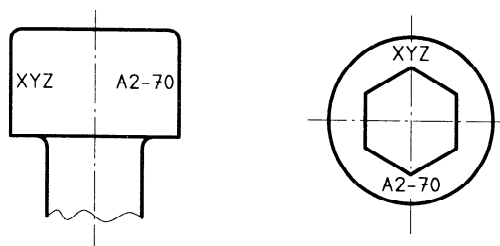

Marking of hexagon and hexalobular socket head cap screws (alternative forms)

iTeh STANDARD PREVIEW
(standards.iteh.ai)

SIST ISO 3506-1:2000
<https://standards.iteh.ai/catalog/standards/sist/8a2455d6-508e-4bd7-99a9-7ae3de0ae/sist-iso-3506-1-2000>

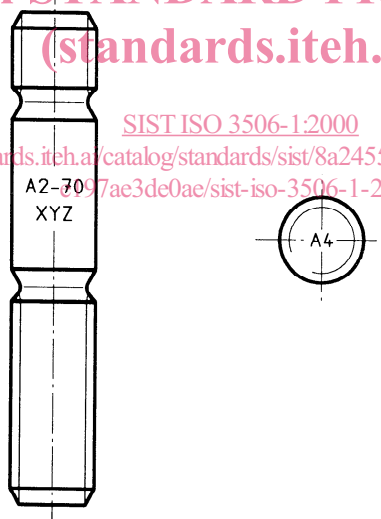

Marking of studs (alternative forms, see 3.2.2)

NOTE — For marking of left-hand thread, see ISO 898-1.

Figure 2 — Marking of bolts, screws and studs

4 Chemical composition

The chemical compositions of stainless steels suitable for fasteners in accordance with this part of ISO 3506 are given in table 1.

The final choice of chemical composition within the specified steel grade is at the discretion of the manufacturer unless by prior agreement between the purchaser and the manufacturer.

In applications where risk of intergranular corrosion is present, testing in accordance with ISO 3651-1 or ISO 3651-2 is recommended. In such cases, stabilized stainless steels A3 and A5 or stainless steels A2 and A4 with carbon content not exceeding 0,03 % are recommended.

Table 1 — Stainless steel grades — Chemical composition

Group	Grade	Chemical composition, % (m/m) ¹⁾									Notes
		C	Si	Mn	P	S	Cr	Mo	Ni	Cu	
Austenitic	A1	0,12	1	6,5	0,2	0,15 to 0,35	16 to 19	0,7	5 to 10	1,75 to 2,25	2) 3) 4)
	A2	0,1	1	2	0,05	0,03	15 to 20	– ⁵⁾	8 to 19	4	7) 8)
	A3	0,08	1	2	0,045	0,03	17 to 19	– ⁵⁾	9 to 12	1	9)
	A4	0,08	1	2	0,045	0,03	16 to 18,5	2 to 3	10 to 15	1	8) 10)
	A5	0,08	1	2	0,045	0,03	16 to 18,5	2 to 3	10,5 to 14	1	9) 10)
Martensitic	C1	0,09 to 0,15	1	1	0,05	0,03	11,5 to 14	–	1	–	10)
	C3	0,17 to 0,25	1	1	0,04	0,03	16 to 18	–	1,5 to 2,5	–	
	C4	0,08 to 0,15	1	1,5	0,06	0,15 to 0,35	12 to 14	0,6	1	–	2) 10)
Ferritic	F1	0,12	1	1	0,04	0,03	15 to 18	– ⁶⁾	1	–	11) 12)

NOTES

- A description of the groups and grades of stainless steels also entering into their specific properties and application is given in annex B.
- Examples for stainless steels which are standardized in ISO 683-13 and in ISO 4954 are given in annexes C and D respectively.
- Certain materials for specific application are given in annex E.

- Values are maximum unless otherwise indicated.
- Sulfur may be replaced by selenium.
- If the nickel content is below 8 %, the minimum manganese content must be 5 %.
- There is no minimum limit to the copper content provided that the nickel content is greater than 8 %.
- Molybdenum may be present at the discretion of the manufacturer. However, if for some applications limiting of the molybdenum content is essential, this must be stated at the time of ordering by the purchaser.
- Molybdenum may be present at the discretion of the manufacturer.
- If the chromium content is below 17 %, the minimum nickel content should be 12 %.
- For austenitic stainless steels having a maximum carbon content of 0,03 %, nitrogen may be present to a maximum of 0,22 %.
- Must contain titanium $\geq 5 \times C$ up to 0,8 % maximum for stabilization and be marked appropriately in accordance with this table, or must contain niobium (columbium) and/or tantalum $\geq 10 \times C$ up to 1,0 % maximum for stabilization and be marked appropriately in accordance with this table.
- At the discretion of the manufacturer the carbon content may be higher where required to obtain the specified mechanical properties at larger diameters, but shall not exceed 0,12 % for austenitic steels.
- May contain titanium $\geq 5 \times C$ up to 0,8 % maximum.
- May contain niobium (columbium) and/or tantalum $\geq 10 \times C$ up to 1 % maximum.

5 Mechanical properties

The mechanical properties of bolts, screws and studs in accordance with this part of ISO 3506 shall conform to the values given in table 2, 3 or 4.

For bolts and screws made of martensitic steel the strength under wedge loading shall not be smaller than the minimum values for tensile strength shown in table 3.

For acceptance purposes the mechanical properties specified in this clause apply and shall be tested according to the test programme in clause 6.