



## Standard Practice for Subsurface Installation of Corrugated Polyethylene Pipe for Agricultural Drainage or Water Table Control<sup>1</sup>

This standard is issued under the fixed designation F449; the number immediately following the designation indicates the year of original adoption or, in the case of revision, the year of last revision. A number in parentheses indicates the year of last reapproval. A superscript epsilon ( $\epsilon$ ) indicates an editorial change since the last revision or reapproval.

### 1. Scope

1.1 This practice is recommended for and limited to gravity flow subsurface drainage systems or water table control, but not recommended for sanitary or storm sewer applications. Procedures are outlined to minimize pipe deflection or structural damage during and after the installation process. These installation procedures are in accordance with “flexible conduit” principles.

1.2 This practice applies to all agricultural subsurface drainage or water table control installations using Specification **F405**, **F667** or other plastic pipe.

1.3 The values stated in inch-pound units are to be regarded as standard. The values given in parentheses are mathematical conversions to SI units that are provided for information only and are not considered standard.

1.4 This standard does not purport to address all of the safety concerns, if any, associated with its use. It is the responsibility of the user of this standard to establish appropriate safety and health practices and determine the applicability of regulatory limitations prior to use.

### 2. Referenced Documents

2.1 *ASTM Standards:*<sup>2</sup>

**D1600** Terminology for Abbreviated Terms Relating to Plastics

**D2412** Test Method for Determination of External Loading Characteristics of Plastic Pipe by Parallel-Plate Loading

**F405** Specification for Corrugated Polyethylene (PE) Pipe and Fittings

**F412** Terminology Relating to Plastic Piping Systems

**F667** Specification for 3 through 24 in. Corrugated Polyethylene Pipe and Fittings

### 3. Terminology

3.1 Definitions are in accordance with Terminology **F412** and abbreviations are in accordance with Terminology **D1600**, unless otherwise specified.

3.2 *backfill*—materials used to fill the trench following installation of the pipe and bedding.

3.3 *bedding*—material which provides stable bottom support for the pipe including the trench bottom groove support angle or select material placed around the pipe, and envelope or filter materials where used during installation.

3.4 *blinding*—the placement of soil, bedding material over and on the sides of the pipe or envelope to ensure proper grade, alignment, support, and protection of pipe during backfilling and after installation.

3.5 *boot (also shield)*—the protecting apparatus linked to the rear of the installation machine in a manner which allows placement of the pipe on the trench bottom, protection of the workman, or placement of envelope or filter material, or both.

3.6 *cradle*—a prefabricated rigid structure designed to provide trench bottom support for the pipe when soil support is inadequate.

3.7 *envelope*—porous material placed around the pipe to provide bedding, improve the flow of ground water into the drain, or function as a filter.

<sup>1</sup> This practice is under the jurisdiction of ASTM Committee **F17** on Plastic Piping Systems and is the direct responsibility of Subcommittee **F17.65** on Land Drainage. Current edition approved Nov. 1, 2008; March 1, 2014. Published November 2009; September 2014. Originally approved in 1976. Last previous edition approved in 2002 as F449 – 02 – (2008). DOI: 10.1520/F0449-02R08; 10.1520/F0449-02R14.

<sup>2</sup> For referenced ASTM standards, visit the ASTM website, www.astm.org, or contact ASTM Customer Service at service@astm.org. For *Annual Book of ASTM Standards* volume information, refer to the standard’s Document Summary page on the ASTM website.

3.8 *filter*—an envelope of natural or synthetic materials placed completely around a drain to permit free water movement into the drain, provide stabilizing support at the soil-filter interface, and restrict movement of silt and sand into the drain.

3.9 *grade*—the slope of the pipe invert.

3.10 *groove support angle*—angle between the radii of the pipe at points of contact with the formed groove of undisturbed soil or a cradle.

3.11 *mineral soils*—soil containing (1) less than 30 % organic matter by weight provided the mineral fraction is 60 % or more clay, or (2) less than 20 % organic matter by weight provided the mineral fraction has no clay, or (3) less than a proportional content of organic matter between 20 and 30 % if the clay content of the mineral fraction is between 0 and 60 %.

3.12 *natural granular envelope*—an envelope of granular material, usually highly permeable well-graded sand and gravel.

3.13 *organic soil*—soil containing (1) 30 % or more organic matter provided the mineral fraction is 60 % or more clay, or (2) 20 % or more organic matter provided the mineral fraction has no clay, or (3) a proportional content of organic matter between 20 and 30 % if the clay content of mineral fraction is between 0 and 60 %. (It is a general rule that a soil is classed as an organic soil (histosol) either if more than one half of upper ~~80 mm (32 in.)~~ 32 in. (80 mm) of soil is organic or if organic soil material of any thickness rests on rock or on fragmental material having voids filled with organic material.)

3.14 *pipe stiffness*—force per unit length, per unit deflection as defined in Test Method D2412.

3.15 *power feeder*—mechanism that applies force to the pipe as it passes through the boot or shield to reduce stretch during installation.

3.16 *pre-ripping*—the practice of making a pass with the plow without installing pipe to locate rocks and to reduce draft.

3.17 *start hole*—a trench sufficiently long and wide to allow working room for placing the boot or shield, blade or cutting mechanism on grade to start the trench and to install connections or pipe.

3.17.1 *Discussion*—

Start holes are usually dug with a backhoe with a flat-bottom trench.

3.18 *stretch*—the increase in length of the pipe caused by tension forces during installation. It is expressed as a percent increase of the length prior to installation. Stretch differs from elongation in that elongation is a material test and stretch is an installation test.

3.19 *synthetic envelope*—an envelope made of synthetic geotextiles, usually thin synthetic fabrics or thicker fibrous material, or both, often selected to function as a filter.

3.20 *trench depth*—the depth of the trench measured from the bottom of the pipe.

3.21 *trench width*—the width of the trench measured at the top of the pipe.

3.22 Fig. 1 illustrates the terms bedding, vertical deflection, backfill material, cover, groove support angle, horizontal deflection, trench width, and trench depth.

Fig. 2 illustrates various support grooves or trench bottom shapes.

Fig. 3 illustrates envelope and filter.

Fig. 4 illustrates rodent protection devices.

Fig. 5 illustrates boot or shield.

## 4. General Requirements

4.1 *Burial*—The maximum and minimum burial depth are affected by the following factors, groove support angle of the trench bottom, bedding, blinding backfill soil density, envelope density, envelope placement, pipe stiffness, the live load expected, desired water table depth, and width of trench.

4.1.1 *Minimum Depth*:

4.1.1.1 *Mineral Soils*—The minimum recommended cover needed to protect the pipe from crushing under live loads is ~~0.6 m (2-ft)~~ 2 ft (0.6 m). Granular bedding or special construction techniques may be used to reduce the cover. The time for consolidation of backfill may be a factor (see 8.1). The minimum cover may have limiting factors other than crushing such as clearance for subsoiling and utility crossing.

4.1.1.2 *Organic Soils*—Subsurface drains should be installed in these soils only after initial subsidence has occurred. To produce initial subsidence open ditches should be constructed in deep organic soils to carry off free water, and the area should be allowed to stand or be partially cultivated for a period of 3 to 5 years before installing pipe. The recommended minimum cover for the pipe in organic soils is ~~0.7 m (2.5 ft)~~ 2.5 ft (0.7 m). If water level controls are not provided in the drainage system to hold subsidence to a minimum, the depth of cover should be increased to ~~0.9 m (3 ft)~~ 3 ft (0.9 m).

NOTE 1—These minimum depths are recommended to prevent crushing of the pipe by normal agricultural vehicle loads. Other drainage factors such as those encountered with salinity control in arid irrigated lands may require minimum depths of ~~1.8 m (6 ft)~~ 6 ft (1.8 m).

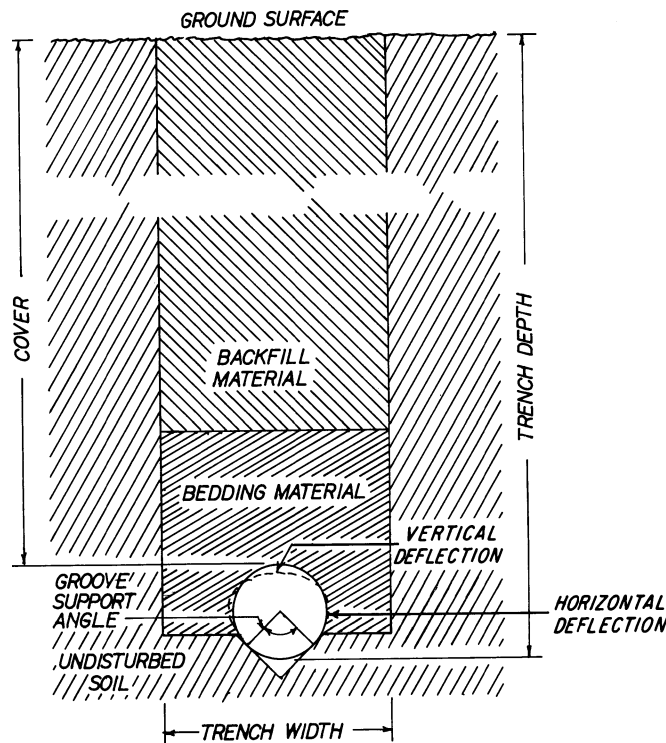

FIG. 1 Terminology for Installation of Plastic Drain Pipe

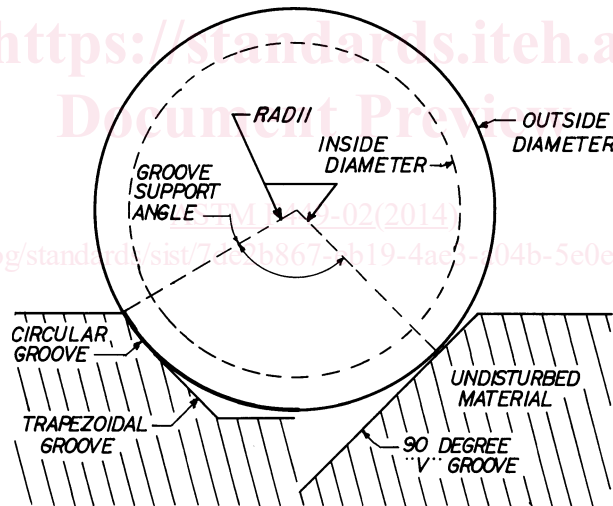

FIG. 2 Support Grooves

4.1.2 *Maximum Depth*—The maximum burial depth is influenced by such factors as degree of compaction, type of bedding, support from the trench bottom, trench width, size of pipe, pipe stiffness, weight of backfill, and live loads imposed. Without an engineering design, maximum buried depths should be limited to those listed in [Table 1](#). For installation at depths greater than those listed in [Table 1](#), specifications of and engineering design should be followed.

4.1.3 *Trench Width*—Increasing the trench width increases the soil load on the pipe. Side clearances of more than 150 mm (6 in.) on each side should only be used with an engineering design and special construction (see [Table 1](#)). Trench width must be at least 50 mm (2 in.) wider than the pipe on each side for plow installation and 75 to 150 mm (3 to 6 in.) on each side for open trench installation to allow sufficient bedding to support the pipe. If fine material cannot be placed alongside and over the pipe, a wider trench should be considered or special bedding material supplied.

4.2 *Design Items*—It is particularly important that blinding, bedding, or envelope material be placed as the pipe is installed, to ensure uniform continuous support, so that the bedding, blinding, or envelope material can provide lateral restraint against pipe deflection as the backfill settles on the bedding, blinding, or envelope material.

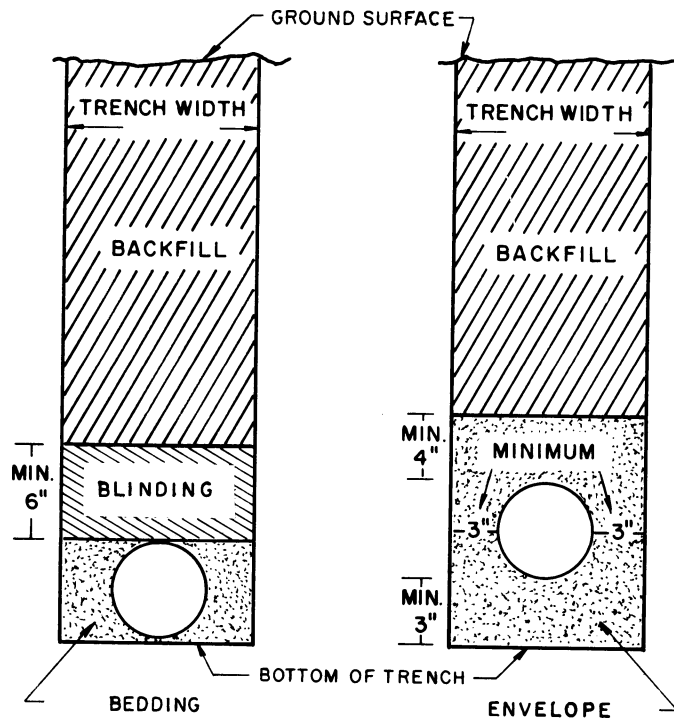

FIG. 3 Pipe Encased in Bedding for Support (left) and Pipe Encased in Sand and Gravel Envelope Designed as Filter (right)

4.3 *Envelopes*—Must be designed to provide adequate support for the pipe, improve the flow of ground water into the pipe, and in some installations, filter flow into the pipe.

4.3.1 *Natural Granular Envelopes*—Minimum thickness of 75 mm (3 in.) around the pipe.

4.3.2 *Synthetic Envelopes*—Blinding or bedding is needed to support and hold the envelope and pipe in place.

4.4 *Filters*—Are required when ground water can develop velocities sufficient to move sand or silt, or both, into the drain. Filters must be able to restrict the movement of these particles into the pipe so that the hydraulic capacity of the pipe is maintained.

4.4.1 *Granular Filters*—Design of a graded sand and fine gravel filter should match the gradation of the specific soil following criteria developed by the Natural Resource Conservation Service, the U.S. Bureau of Reclamation, or the U.S. Army Corps of Engineers.

4.4.2 *Synthetic Filters*—Thin synthetic fabric material or geotextiles may be used where bedding, soil, and hydraulic conditions permit. The openings in synthetic filters must be compatible with the soil that surrounds the drain to prevent excessive movement of soil that otherwise could plug the drain or filter (see 5.3).

NOTE 2—These filters must be specified to be compatible with the soil type that encompasses the conduit since protective filters can plug and decrease the inflow capability. Where fiberglass filter material is used, it shall be manufactured from borosilicate-type glass and the manufacturer shall certify that it is suitable for underground use. The fibers should be of variable size, with some larger fibers intertwined in the mat in a random manner.

NOTE 3—Vegetative filter material such as straw, hay, corn-cobs, woodchips, sawdust, and coconut fiber are not recommended for use with flexible conduits because such conduits depend on the development of lateral support and these soft materials may not provide the necessary lateral support.

4.5 *Grade*—Shall be as specified in the plan or guide. Deviations greater than the following shall not be allowed. Vertical deviations of more than 0.1 ft (30.5 mm) in 10 ft (3.05 m). Negative grade that would fill the pipe more than 10 %. Due to the speed of installation with the plow, automatic grade control is recommended. The pipe feeding system shall hold the pipe in place in the bottom of the trench until secured by the bedding, blinding, or envelope material.

4.6 *Material Requirements*—Pipe and fittings shall meet the requirements of the applicable ASTM standards referenced in Section 2 and Table 1.

## 5. Significant Factors in Pipe/Soil Interactions

5.1 *Connections*—In start holes and adjacent open trenches, the pipe shall be aligned both vertically and horizontally, blinded and hand tamped along the sides of the pipe to prevent excessive deflection.

5.2 *Deflection*—The deflection of corrugated plastic pipe is related to installation practice, bedding, groove support angle, blinding, gradation and density of soil, depth of installation, trench width in relation to pipe size, live loads imposed, stretch, and pipe stiffness of pipe. Maximum pipe deflection should be specified and not exceed 10 % of its nominal diameter.

5.3 *Filters*—Synthetic materials should never be used when the soil has a silt content greater than 40 %.