



# Standard Specification for ASTM Liquid-in-Glass Thermometers<sup>1</sup>

This standard is issued under the fixed designation E1; the number immediately following the designation indicates the year of original adoption or, in the case of revision, the year of last revision. A number in parentheses indicates the year of last reappraisal. A superscript epsilon ( $\epsilon$ ) indicates an editorial change since the last revision or reappraisal.

*This standard has been approved for use by agencies of the U.S. Department of Defense.*

## 1. Scope

1.1 This specification covers liquid-in-glass thermometers graduated in degrees Celsius or degrees Fahrenheit that are frequently identified and used in methods under the jurisdiction of the various technical committees within ASTM. The various thermometers specified are listed in Table 1. The inclusion of an IP number in Table 1 indicates, where appearing, that the thermometer specification has been jointly agreed upon by the British Institute of Petroleum (IP) and ASTM.

1.2 This specification also covers adjustable-range enclosed-scale thermometers, graduated in degrees Celsius, which are used in ASTM methods.

1.3 The enclosed-scale thermometers are commonly called Beckmann thermometers. They are suitable for measuring small temperature differences not exceeding 6 °C within a larger range of temperature. The thermometers are unsuitable for measuring Celsius- or kelvin-scale temperatures unless they have been compared with standard instruments immediately before use.

1.4 An alphabetic list of the ASTM Thermometers included in this standard is given in Table 2.

1.5 A list of ASTM Thermometers is given in Table 3 to facilitate selection according to temperature range, immersion, and scale-error requirements.

NOTE 1—For a listing of thermometers recommended for general laboratory use, the Scientific Apparatus Makers Association Specifications for General Purpose Glass Laboratory Thermometers may be consulted.<sup>2</sup>

NOTE 2—It has been found by experience that these ASTM Thermometers, although developed in general for specific tests, may also be found suitable for other applications, thus precluding the need for new thermometer specifications differing in only minor features. However, it is suggested that technical committees contact Subcommittee E20.05 before choosing a currently specified thermometer for a new method to be sure

the thermometer will be suitable for the intended application.

1.6 The thermometers found in Table 1 contain mercury, mercury thallium eutectic alloy, or toluene or other suitable liquid colored with a permanent red dye. For low-hazard precision non-mercury alternatives to E1 thermometers, see Specification E2251.

1.7 **WARNING**—Mercury has been designated by EPA and many state agencies as a hazardous material that can cause central nervous system, kidney and liver damage. Mercury, or its vapor, may be hazardous to health and corrosive to materials. Caution should be taken when handling mercury and mercury containing products. See the applicable product Material Safety Data Sheet (MSDS) for details and EPA's website: <http://www.epa.gov/mercury/faq.htm> - for additional information. Users should be aware that selling mercury and/or mercury containing products into your state may be prohibited by state law.

1.8 *This standard does not purport to address all of the safety concerns, if any, associated with its use. It is the responsibility of the user of this standard to establish appropriate safety and health practices and determine the applicability of regulatory limitations prior to use.*

## 2. Referenced Documents

### 2.1 ASTM Standards:<sup>3</sup>

E77 Test Method for Inspection and Verification of Thermometers

E344 Terminology Relating to Thermometry and Hydrometry

E563 Practice for Preparation and Use of an Ice-Point Bath as a Reference Temperature

E2251 Specification for Liquid-in-Glass ASTM Thermometers with Low-Hazard Precision Liquids

## 3. Terminology

3.1 *Definitions*—The definitions given in Terminology E344 apply.

<sup>3</sup> For referenced ASTM standards, visit the ASTM website, [www.astm.org](http://www.astm.org), or contact ASTM Customer Service at [service@astm.org](mailto:service@astm.org). For *Annual Book of ASTM Standards* volume information, refer to the standard's Document Summary page on the ASTM website.

<sup>1</sup> This specification is under the jurisdiction of ASTM Committee E20 on Temperature Measurement and is the direct responsibility of Subcommittee E20.05 on Liquid-in-Glass Thermometers and Hydrometers.

Current edition approved May 1, 2014. Published September 2014. Originally approved in 1939. Last previous edition approved in 2013 as E1 – 13. DOI: 10.1520/E0001-14.

<sup>2</sup> Available from SAMA Group of Assocs., 225 Reinekers, Ste. 625, Alexandria, VA 23314.

### 3.2 Definitions of Terms Specific to This Standard:

3.2.1 *adjusting device, n*—a section of the instrument used to adjust the amount of mercury in the bulb and main capillary to that needed for the intended temperature interval.

3.2.2 *bulb length, n*—the distance from the bottom of the bulb to the junction of the bulb and the stem tubing.

3.2.3 *contraction chamber, n*—an enlargement of the capillary, that will appear below the main scale or between the main scale and the auxiliary scale, which serves to reduce its length or to prevent contraction of the liquid column into the bulb.

3.2.4 *diameter, n*—the largest outside dimension of the glass as measured with a ring gage.

3.2.5 *expansion chamber, n*—an enlargement at the top of the capillary to provide protection against breakage caused by excessive gas pressure.

3.2.6 *interval error, n*—the deviation of the nominal value of a temperature interval from its true value; either for the total range (total interval) or for a part of the range (partial interval).

3.2.7 *saddle, n*—the bottom support of the enclosed scale.

3.2.8 *setting temperature, n*—the temperature that yields a reading of zero on the main scale for a given adjustment of the amount of mercury in the bulb and main capillary.

3.2.9 *thermometric liquid, n*—the liquid in a liquid-in-glass thermometer that indicates the value of temperature.

3.2.10 *top of the thermometer, n*—the top of the finished instrument.

3.2.11 *total length, n*—overall length of the finished instrument.

3.2.12 Other descriptions of terms shall be in accordance with the Terminology section of Test Method E77.

## Part A—Solid-Stem Thermometers

### 4. Specifications

4.1 The individual thermometers shall conform to the detailed specifications given in Table 1 and to the general requirements specified in Sections 5 – 15.

4.2 Thermometers manufactured to previous revisions of this specification shall retain the same ASTM status as those meeting current specifications.

4.3 The encapsulation (jacketing) of the glass of liquid-in-glass thermometers with polyfluorinated hydrocarbons will change their performance and physical characteristics, including, but not limited to, response time, accuracy, and physical dimensions. Therefore, under no circumstances should an encapsulated or otherwise modified ASTM thermometer be used in performing tests that specify the use of an ASTM thermometer.

### 5. Type

5.1 The thermometers, as specified in Table 1, shall be filled with one of the following liquids:

5.1.1 Mercury,

5.1.2 Mercury thallium eutectic alloy, or

5.1.3 Toluene or other suitable liquid colored with a permanent red dye.

5.2 The filling above the liquid shall be nitrogen or other suitable inert gas.

### 6. Stem

6.1 *Stem*—The stem shall be made of suitable thermometer tubing and shall have a plain front and enamel back, unless otherwise specified in Table 1.

6.2 *Top Finish*—The top of all thermometers specified in Table 1 shall have a plain rounded finish, except the following which shall have the top finish indicated below (unless indicated as optional). Any special top finish shall be included in the total length of the thermometer.

6.2.1 *Glass Button Finish:*

Thermometers 23C, 24C, and 25C

6.2.2 *Special Finish:*

6.2.2.1 Suitable for assembly in a standard 304.8-mm (12-in.) non-sparking metal armor with open face; in a cup case assembly; or in a flushing case assembly:

Thermometers 58C, 58F, 59C, 59F, 60C, 60F, 97C, 97F, 98C, 98F, 130C, and 130F

6.2.2.2 Suitable for assembly in a 12-in. non-sparking metal armor with open face:

Thermometer 99C, 99F

6.2.3 *Ring Top (optional only)*—Thermometers 11C and 11F.

### 7. Bulb

7.1 The bulb shall be made of glass having a viscosity of at least  $10^{14.6}$  poises at 490 °C (914 °F) and at least  $10^{13.4}$  poises at 520 °C (968 °F).

7.2 Thermometers made with bulb glasses not meeting the minimum properties in 7.1 shall not be subjected to temperatures above 405 °C (760 °F) or be continuously exposed to temperatures above 370 °C (700 °F).

### 8. Capillary Clearances

8.1 The following distances between graduations and the bulb, and between graduations and enlargements in the capillary, shall be minimum limits for thermometers in this specification.

NOTE 3—In order for a thermometer to be usable over its entire graduated range, graduation marks should not be placed too close to any enlargement in the capillary. Insufficient immersion of the thermometric liquid in the main bulb or capillary enlargement, graduation marks placed over parts of the capillary that have been changed by manufacturing operations, or graduations so close to the top of the thermometer that excessive gas pressure results when the thermometric liquid is raised to this level, may lead to appreciable errors.

8.1.1 A 13-mm length of unchanged capillary between the bulb and the immersion line or lowest graduation, if the graduation is not above 100 °C (212 °F); a 30-mm length if the graduation is above 100 °C (212 °F).

8.1.2 A 5-mm length of unchanged capillary between an enlargement and the graduation next below, except at the top of the thermometer.

8.1.3 A 10-mm length of unchanged capillary between an enlargement, other than the bulb, and the immersion line or the graduation next above, if the graduation is not above 100 °C (212 °F); a 30-mm length if the graduation is above 100 °C (212 °F).

8.1.4 A 10-mm length of unchanged capillary above the highest graduation, if there is an expansion chamber at the top of the thermometer; a 30-mm length if there is no expansion chamber. For the purposes of this requirement, “an expansion chamber” is interpreted as an enlargement at the top end of the capillary bore which shall have a capacity equivalent to not less than 20 mm of unchanged capillary.

8.2 It is possible to manufacture thermometers that comply with the specifications given in Table 1, but do not meet the requirements for capillary clearances given above. In any case, the distances given in this section shall be the governing factor. Under no circumstances shall the scales on thermometers be placed closer than these minimum distances.

## 9. Graduations and Incriptions

9.1 All graduation lines, immersion lines, figures, and letters shall be clearly defined, suitably colored, and permanent. The width and the sharpness of the graduation lines shall be in accordance with 9.2. The middle of the graduation line shall be determinable.

9.1.1 A suitably etched thermometer with the etched lines and figures filled with a pigment shall be considered permanently marked provided it passes the test for permanency of pigment in Section 11.

9.1.2 A thermometer marked by other means shall also be considered permanently marked, provided it passes the test for permanency of pigment in Section 11.

9.2 *Graduation Lines*—All graduation lines shall be straight, of uniform width, and perpendicular to the axis of the thermometer. The width of the graduation lines shall be as follows:

9.2.1 *Group 1*—Maximum line width 0.10 mm; for thermometers that may read to fractions of a division, often with magnifying aids:

Thermometers 14C, 14F, 26C, 28C, 28F, 29C, 29F, 30F, 33C, 33F, 34C, 34F, 35C, 35F, 44C, 44F, 45C, 45F, 46C, 46F, 47C, 47F, 48C, 48F, 50F, 51F, 52C, 56C, 56F, 62C, 62F, 63C, 63F, 64C, 64F, 65C, 65F, 66C, 66F, 67C, 67F, 68C, 68F, 69C, 69F, 70C, 70F, 72C, 72F, 73C, 73F, 74C, 74F, 89C, 90C, 91C, 92C, 93C, 94C, 95C, 96C, 100C, 101C, 110C, 110F, 111C, 112C, 113C, 113F, 116C, 117C, 118C, 118F, 119C, 119F, 120C, 121C, 126C, 126F, 127C, 128C, 128F, 129C, 129F, 132C, 133C, and 137C.

9.2.2 *Group 2*—Maximum line width 0.15 mm; for thermometers that may be read to the nearest half division or where the congestion of scale dictates the use of a scale with moderate fineness:

Thermometers 1C, 1F, 2C, 2F, 3C, 3F, 5C, 5F, 6C, 6F, 7C, 7F, 8C, 8F, 9C, 9F, 10C, 10F, 11C, 11F, 12C, 12F, 13C, 15C, 15F, 16C, 16F, 17C, 17F, 18C, 18F, 19C, 19F, 20C, 20F, 21C, 21F, 22C, 22F, 23C, 24C, 25C, 36C, 37C, 38C, 39C, 40C, 41C, 42C, 43C, 43F, 49C, 54C, 54F, 61C, 61F, 71C, 71F, 82C, 82F, 83C, 83F, 84C, 84F, 85C, 85F, 86C, 86F, 87C, 87F, 99C, 99F, 102C, 103C, 104C, 105C, 106C, 107C, 108F, 109F, 114C, 122C, 123C, 124C, 125C, 134C, 135C, 135F, 136C, and 136F.

9.2.3 *Group 3*—Maximum line width 0.20 mm; for thermometers with more open scales, usually read to the nearest

division, often times under adverse conditions where a bold graduation is therefore desired:

Thermometers 27C, 57C, 57F, 58C, 58F, 59C, 59F, 60C, 60F, 75F, 76F, 77F, 78F, 79F, 80F, 81F, 88C, 88F, 97C, 97F, 98C, 98F, 130C, and 130F.

9.3 *Immersion Line*—On partial immersion thermometers an immersion line shall be permanently marked on the front of the thermometer at the distance above the bottom of the bulb as specified in Table 1 within a tolerance of  $\pm 0.5$  mm, except for Thermometers 82F to 87F, which shall have no immersion line. The immersion inscription shall be written in capital letters and abbreviated (for example, 76 mm immersion shall be written 76 MM IMM).

9.4 *Terminal Numbers*—The terminal number shall be in full when there are one or more numbered graduations between it and the last full number, before the terminal number. This rule need not necessarily be followed for:

9.4.1 *Saybolt Viscosity Thermometers* :

17C, 17F, 19C, 19F, 20C, 20F, 21C, 21F, 77F, 78F, 79F, 80F, and 81F

9.4.2 *Kinematic Viscosity Thermometers*:

28F, 29F, 30F, 44F, 45F, 46F, 47F, 48F, 72F, 73F, 74F, 110F, 118F, 126F, 128F, and 129F

9.4.3 *Engler Viscosity Thermometers* :

23C, 24C, and 25C

9.4.4 *Precision Thermometers*:

65F, 66F, 67C, 67F, and 68C

9.4.5 *Tank Thermometer*:

97F

9.4.6 *Solidification Point Thermometers*:

100C and 101C

9.4.7 *Reid Vapor Pressure*:

18C and 18F

9.4.8 *Oxidation Stability*:

22C and 22F

9.5 *Scale Below Zero*—When a scale extends both above and below 0 °C or 0 °F, the two parts of the scale shall be differentiated by some means. Examples of suitable means are:

9.5.1 Different pigment colors for the two parts of the scale,

9.5.2 Different style of numerical characters for the two parts of the scale, and

9.5.3 Use of minus signs before appropriate numbers below 0 °C or 0 °F.

## 10. Special Inscription

10.1 The special inscription specified in Table 1 shall be marked on the thermometer in capital letters and Arabic numbers without the use of periods. In addition to the special inscription prescribed in Table 1, each thermometer shall be permanently marked with a unique serial number and the manufacturer’s tradename or mark.

10.2 *Engraving Revision Date on ASTM Thermometers*—Include year of current revision in ASTM designation (for example, ASTM 1C-99).

**11. Permanency of Pigment**

11.1 The test for permanency of pigment is designed to determine the ability of the pigment material to withstand the exposure conditions encountered in use without being obliterated.

11.2 Place any convenient portion of the scale section of the thermometer to be tested in an oven of the type shown in Fig. 1. Heat for 3 h at approximately 260°C (500°F). Allow to cool slowly. Inspect the thermometer for differences in appearance of the tested and untested sections of the scale portion. Burning out, loosening, chalking, or fading of the pigment shall be cause for rejection.

**12. Bulb Stability**

12.1 The test for bulb stability shall be made for the following thermometers in the temperature range specified below for 24 h. The scale indications after the test shall be within the maximum scale error specified in Table 1. Observations of a reference point before and after the test to give a measure of the degree of bulb stability achieved in manufacture. The bulb is considered stable if the change in indications

of the thermometer in the test is no more than 0.7 (7/10) of the maximum scale error found in Table 1.

ASTM Thermometer Number	Test Temperature Range
3C, 8C, 10C, 11C, 70C	360 to 370°C
3F, 8F, 10F, 11F, 70F	680 to 700°F
2C, 7C, 69C, 107C	280 to 290°C
2F, 7F, 69F	540 to 560 °F

12.1.1 The test for bulb stability is designed to determine the adequacy of the stabilizing heat treatment accorded the thermometer bulb during manufacture. An inadequately stabilized bulb will undergo shrinkage with time which may be significant particularly in higher temperatures.

12.1.1.1 Heat the thermometer for 5 min at the temperature specified above in a preheated bath which may be of the type shown in Fig. 2. Immersion must be sufficient that all of the thermometer bulb is at the specified temperature. Allow the thermometer to cool, either naturally in still air, or slowly in the test bath at a specified rate, to a span of 20° on the Celsius scale (36° on the Fahrenheit scale) above ambient temperature or to 50°C (122°F), whichever is the lower, and then determine the reading at some reference point, such as the ice point. If natural

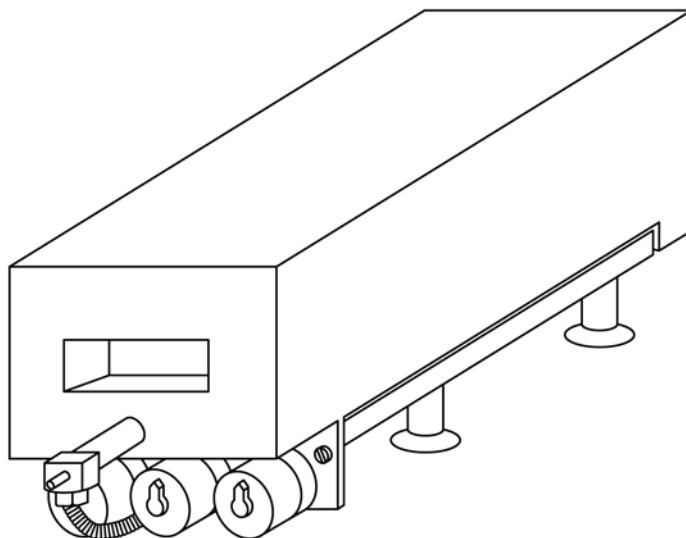
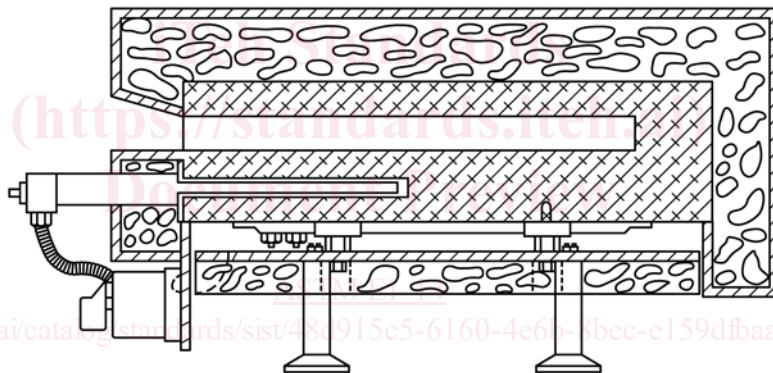

FIG. 1 Oven for Permanency of Pigment Test

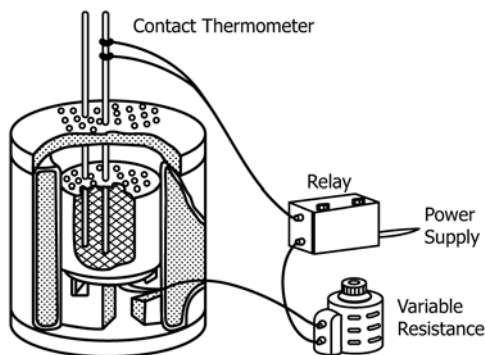

FIG. 2 Air Bath for Bulb Stability Test

cooling in still air is used, determine the reference reading within 1 h. Return the thermometer to the bath, preheated to the temperature of test, and heat for 24 h. Allow the thermometer to cool, at the same rate as at the start of the test, to the temperature referred to above, and redetermine the reference reading under the same conditions as before. The magnitude of any change in this reference reading as a result of the 24-h heating period is a measure of the quality of the bulb glass and the adequacy of the previous heat treatment accorded the thermometer in manufacture.

12.1.2 For kinematic viscosity thermometers used for measuring temperatures at and above 50°C (122°F), the following bulb stability test is used.

12.1.2.1 Heat the thermometer to the selected reference point on the main scale, maintain the temperature for at least 15 min, and determine the scale correction at this point.

12.1.2.2 Allow the thermometer to cool slowly in the test bath (or naturally in still air) to at least a span of 20° on the Celsius scale (36° on the Fahrenheit scale) above ambient or to 50°C (122°F), whichever is the lower, and then determine the correction after at least 15 min at the ice point. If natural cooling is used, the correction should be determined within 1 h.

12.1.2.3 Heat the thermometer again to the selected reference point on the main scale, keep it at this temperature for 168 h. Allow the thermometer to cool as described in 12.1.2.2 and then repeat the procedures described in 12.1.2.1 and 12.1.2.2. It must be emphasized that to obtain meaningful results, the procedure adopted after the 168-h period of heating must be identical to that used in the original calibration.

### 13. Scale Error

13.1 Thermometers shall be verified and calibrated at the temperatures specified in Table 4. Partial immersion thermometers shall be calibrated for the emergent stem temperatures specified in Table 4.

13.1.1 At the time of purchase, the scale errors shall be within the maximum scale error found in Table 1. The indications of many high temperature and fractionally graduated thermometers may change with time and continued use due to minute changes in bulb volume. Periodic verification of these thermometers, either over the entire scale or reverification at a reference temperature (ice point or steam point), in accordance with procedures set forth in Test Method E77, is recommended. For additional information on preparing ice-point baths see Practice E563.

13.2 Due to the application requirements for range and construction of the following thermometers, it is not practical to include reference points such as the ice and steam points.

- 13C, 14C, 14F, 17C, 17F, 18C, 18F, 19C, 19F, 20C, 20F, 21C, 21F, 23C, 24C, 26C, 27C, 38C, 49C, 50F, 51F, 56C, 56F, 76F, 77F, 78F, 79F, 80F, 81F, 83C, 83F, 84C, 84F, 87C, 87F, 91C, 92C, 93C, 96C, 98C, 98F, 100C, 101C, 102C, 103C, 104C, 105C, 106C, 107C, 108F, 109F, 111C, 116C, 117C, 122C, 123C, and 124C

### 14. Case

14.1 Each thermometer shall be supplied in a suitable case on which shall appear the following marking (except when a transparent case is used): the letters “ASTM,” the thermometer number (33C, 33F, etc.), and the temperature range.

### 15. Methods of Verification and Calibration

15.1 Thermometers shall be verified and calibrated at the specified immersion in accordance with Test Method E77.

15.2 For partial immersion thermometers, careful consideration of emergent stem temperatures shall be observed.

15.2.1 During the manufacture of partial immersion thermometers, the manufacturer shall calibrate the thermometers so the indicated temperatures are within the maximum permissible errors found in Table 1 when the emergent stem temperatures found in Table 4 are applied to the readings.

NOTE 4—To achieve the requirements in 15.2.1, the manufacturer may have to measure emergent stem temperatures above its bath, calculate correction factors, and offset its calibrations accordingly. See Test Method E77 for the procedure to correct for emergent stem temperatures.

**TABLE 1 Specification for ASTM Thermometers**

All dimensions are in millimeters.  
See Table 4 for Verification and Calibration Temperatures.

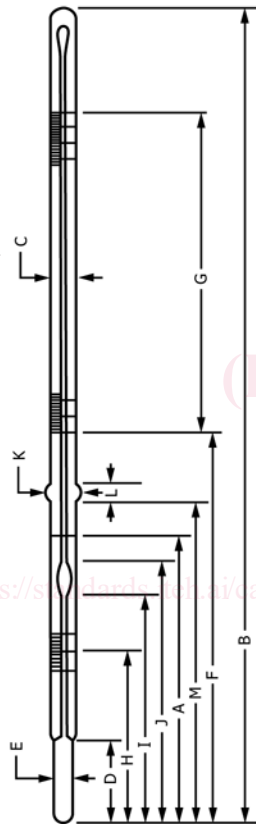

**Explanatory Notes:**

- <sup>A</sup> An expansion chamber is provided for relief of gas pressure to avoid distortion of the bulb at higher temperatures. It is not for the purpose of joining mercury separations and under no circumstances should the thermometer be heated above the highest temperature reading.
- <sup>B</sup> Toluene or other suitable liquid colored red with a permanent dye shall be used as the actuating liquid.
- <sup>C</sup> Under certain test conditions, the bulb of the thermometer may be 28 °C (50 °F) above the temperature indicated by the thermometer, and at an indicated temperature of 371 °C (700 °F) the temperature of the bulb is approaching a critical range in the glass. It is therefore not desirable to use this thermometer under such conditions at indicated temperatures above 371 °C (700 °F) without checking the ice point.
- <sup>D</sup> Longest graduation lines at 155 °C, 160 °C, 162 °C, 164 °C, 165 °C, and 170 °C, with arrows at 162 °C and 164 °C.
- <sup>E</sup> The length of the enlargement, and the distance from the bottom of the enlargement to the bottom of the bulb shall be measured with the test gage shown in Fig. 1.
- <sup>F</sup> Long, narrow shape.
- <sup>G</sup> The test temperature shall be indicated by an arrow whether the graduation corresponding to that point is numbered or not.
- <sup>H</sup> Long, narrow shape; mercury shall be in the chamber at 0 °C (32 °F).
- <sup>I</sup> The thermometer shall be made to be mounted in a brass ferrule consisting of a tubular bushing 8.0 mm in outside diameter with a flanged head approximately 12 mm in diameter so that the upper extremity of the 8.0 mm diameter is located 90 mm from the bottom of the bulb.
- <sup>J</sup> To be marked on the glass stem at least 90 mm from the bottom of the bulb.
- <sup>K</sup> Glass button finish, see 6.2.1.
- <sup>L</sup> Long, narrow shape; mercury shall be near bottom of the chamber at 0 °C.
- <sup>M</sup> For kinematic viscosity thermometers, the ice-point reading shall be taken within 1 h after being at the test temperature for not less than 3 minutes. The ice-point reading shall be expressed to the nearest 0.01 °C or 0.02 °F and applied as explained in Test Method E77, Section 13.
- <sup>N</sup> Thermometers made to these specifications conform also with the requirements for the titer test thermometer of the American Oil Chemists Society and the Association of Official Agricultural Chemists, except for the special inscription.
- <sup>O</sup> Capillary clearances must conform to Section 8.
- <sup>P</sup> Mercury shall be near middle of chamber at 0 °C.
- <sup>Q</sup> The stem may be either the plain front or lens front type. If the thermometer is of the lens front type, the cross section of the stem shall be such that it will pass through an 8-mm ring gage but will not enter a 5-mm slot gage.
- <sup>R</sup> A suitable mercury-thallium alloy shall be used as the actuating liquid.
- <sup>S</sup> The expansion chamber shall be of the long narrow type 10 to 20 mm in length. The length of unchanged capillary between the nearest graduation mark and the expansion chamber shall be not less than 10 mm.
- <sup>T</sup> Mercury shall be near the bottom of the chamber at 0 °C.
- <sup>U</sup> The length of unchanged capillary between the nearest graduation mark and contraction chamber shall be not less than 10 mm.
- <sup>V</sup> Change in correction over any 5 °F interval shall not exceed 0.10 °F.
- <sup>W</sup> Expansion chamber shall be of the long narrow type and there shall be not less than 10 mm of unchanged capillary between the base of the chamber and the top graduation.
- <sup>X</sup> Mercury shall be in the chamber at 32 °F.
- <sup>Y</sup> Over any interval of 2 °C the change in correction shall not exceed 0.02 °C.
- <sup>Z</sup> Over any interval of 4 °F the change in correction shall not exceed 0.05 °F.
- <sup>AA</sup> Special finish, see 6.2.2.
- <sup>BB</sup> The bulb diameter shall not be more than 0.5 mm greater than the stem.
- <sup>CC</sup> The stem shall be of the lens front type. The cross section of the stem shall be such that it will pass through a 8.0-mm ring gage but will not enter a 5.0-mm slot gage. A minor diameter of 4 mm is permissible provided that the major diameter is not less than 7 mm.
- <sup>DD</sup> Bulb bottom shall be essentially hemispherical.
- <sup>EE</sup> Immersion line shall be omitted.

<sup>FF</sup> For Fahrenheit thermometers, dimension G (length of graduated portion) shall be measured as the length of graduated portion corresponding to the nominal Celsius range.

<sup>GG</sup> The immersion line shall be visible in the case opening after assembly. The immersion shall be measured from the bottom of the bulb rather than from the bottom of the arm. See 6.2.2.

<sup>HH</sup> The stem shall be either the round or lens-front type.

<sup>I</sup> Contraction chamber to be long narrow type.

<sup>JJ</sup> Over any interval of 1 °C the change in correction shall not exceed 0.01 °C. The correction at the lowest temperature of the nominal range shall not change by more than 0.02 °C immediately after the thermometer has been heated for 15 min at a temperature 30 °C higher, and allowed to cool naturally in air.

<sup>KK</sup> The capillary bore shall be large enough in relation to the bulb to ensure that (without tapping) jumping of the meniscus does not exceed one half of the smallest scale division, when the temperature is rising at a uniform rate not exceeding 0.05 °C/min.

<sup>LL</sup> The thermometer is to be calibrated for 100-mm immersion for the main scale, the ice point is to be calibrated for total immersion.

<sup>MM</sup> Bulb shape ellipsoidal (see Fig. 2).

<sup>NW</sup> This thermometer may be furnished with an optional ring top. See 6.2.3. Addition of a ring top will increase the total length by an amount equal to the outside diameter of the ring.

<sup>OO</sup> The stem shall be of the lens front type. The cross section of the stem shall be such that it will pass through a 7.0 mm ring gage.

ASTM No.	1C-99	1F-99 <sup>FF</sup>	2C-99	2F-99 <sup>FF</sup>	3C-99	3F-99 <sup>FF</sup>
IP No.			62C		73C	
Name						
Reference Fig. No.						
Range	-20 to +150°C	0 to 302°F	-5 to +300°C	20 to 580°F	-5 to +400°C	20 to 760°F
For test at						
A Immersion, mm		76		76		76
Graduations:						
Subdivisions	1°C	2°F	1°C	2°F	1°C	2°F
Long lines at each	5°C	10°F	5°C	10°F	5°C	10°F
Numbers at each	10°C	20°F	10°C	20°F	10°C	20°F
Scale error, max	0.5°C	1°F	1°C	2°F	1°C to 301°C 1.5°C above 301°C	2°F to 574°F 3°F above 574°F
Special inscription		ASTM 1C-99 or 1F-99 76 MM IMM		ASTM 2C-99 or 2F-99 76 MM IMM		ASTM 3C-99 or 3F-99 76 MM IMM
Expansion chamber:						
Permit heating to	200°C	392°F				
B Total length, mm		317 to 327				
C Stem OD, mm		6.0 to 7.0		385 to 395		410 to 420
D Bulb length, mm		19 to 25		6.0 to 7.0		6.0 to 7.5
E Bulb OD, mm		5.0 to 6.0		10 to 15		10 to 15
Scale location:				5.0 to 6.0		5.0 to 6.0
Bottom of bulb to line at						
F Distance, mm	0°C	32°F	0°C	32°F	0°C	32°F
G Length of graduated portion, mm		111 to 118 170 to 200 <sup>o</sup>		100 to 110 225 to 265 <sup>o</sup>		100 to 110 250 to 290 <sup>o</sup>
Ice-point scale:						
Range						
H Bottom of bulb to ice-point, mm						
Contraction chamber:						
I Distance to bottom, min, mm						
J Distance to top, max, mm						
Stem enlargement:						
K OD, mm						
L Length, mm						
M Distance to bottom, mm						

<sup>A</sup> An expansion chamber is provided for relief of gas pressure to avoid distortion of the bulb at higher temperatures. It is not for the purpose of joining mercury separations and under no circumstances should the thermometer be heated above the highest temperature reading.

<sup>B</sup> Under certain test conditions, the bulb of the thermometer may be 28°C (50°F) above the temperature indicated by the thermometer, and at an indicated temperature of 371°C (700°F) the temperature of the bulb is approaching a critical range in the glass. It is therefore not desirable to use this thermometer under such conditions at indicated temperatures above 371°C (700°F) without checking the ice point.

<sup>O</sup> Capillary clearances shall conform to Section 8.

<sup>FF</sup> For Fahrenheit thermometers, dimension G (length of graduated portion) shall be measured as the length of graduated portion corresponding to the nominal Celsius range.

**TABLE 1 Continued**

	ASTM No.	5C-86	5F-86 <sup>FF</sup>	6C-86	6F-86 <sup>FF</sup>	7C-86	7F-86 <sup>FF</sup>
IP No.		1C		2C		5C	
Name		Cloud and Pour	Cloud and Pour	Low Cloud and Pour <sup>B</sup>	Low Distillation		
Reference Fig. No.		3	3	3	4		
Range		-38 to + 50°C	-36 to + 120°F	-80 to + 20°C	-112 to + 70°F	-2 to + 300°C	30 to 580°F
For test at							
A Immersion, mm		108		76		total	
Graduations:							
Subdivisions		1°C	2°F	1°C	2°F	1°C	2°F
Long lines at each		5°C	10°F	5°C	10°F	5°C	10°F
Numbers at each		10°C	20°F	10°C	20°F	10°C	20°F
Scale error, max		0.5°C	1°F	1°C to -33°C	2°F to -28°F	0.5°C to 150°C	1°F to 300°F
Special inscription		ASTM 5C-86 or 5F-86 108 MM IMM	ASTM 6C-86 or 6F-86 76 MM IMM	ASTM 6C-86 or 6F-86 76 MM IMM	ASTM 7C-86 or 7F-86	ASTM 7C-86 or 7F-86	
Expansion chamber:							
Permit heating to		100°C	212°F	60°C	140°F	A	
B Total length, mm			225 to 235		225 to 235	380 to 390	
C Stem OD, mm			6.0 to 8.0		6.0 to 8.0	6.0 to 8.0	
D Bulb length, mm			7 to 10		7 to 10	10 to 15	
E Bulb OD, mm			<5.5 and ≥stem		<5.0 and ≥stem	<5.0 and ≥stem	
Scale location:							
Bottom of bulb to line at		-38°C	-36°F	-70°C	-94°F	0°C	32°F
F Distance, mm			120 to 130		100 to 120	100 to 110	
G Length of graduated portion, mm			65 to 85 <sup>o</sup>		70 to 100 <sup>o</sup>	225 to 255 <sup>o</sup>	
Ice-point scale:							
Range							
Bottom of bulb to ice-point, mm							
Contraction chamber:							
I Distance to bottom, min, mm							
J Distance to top, max, mm							
Stem enlargement:							
K OD, mm							
L Length, mm							
M Distance to bottom, mm							
<sup>A</sup> An expansion chamber is provided for relief of gas pressure to avoid distortion of the bulb at higher temperatures. It is not for the purpose of joining mercury separations and under no circumstances should the thermometer be heated above the highest temperature reading. <sup>B</sup> Toluene or other suitable liquid colored red with a permanent dye shall be used as the actuating liquid. <sup>o</sup> Capillary clearances shall conform to Section 8. <sup>FF</sup> For Fahrenheit thermometers, dimension G (length of graduated portion) shall be measured as the length of graduated portion corresponding to the nominal Celsius range.							
IP No.		6C	8F-86 <sup>FF</sup>	9C-86	9F-86 <sup>FF</sup>	10C-86	10F-86 <sup>FF</sup>
Name		High Distillation	High Distillation	Low-Pensky-Martens	Low-Pensky-Martens	High-Pensky-Martens	
Reference Fig. No.		4	4	5	5	5	
Range		-2 to + 400°C <sup>C</sup>	30 to 760°F <sup>C</sup>	-5 to + 110°C	20 to 230°F	90 to 370°C	200 to 700°F
For test at							
A Immersion, mm				57			57
Graduations:							
Subdivisions		1°C	2°F	0.5°C	1°F	2°C	5°F
Long lines at each		5°C	10°F	1°C and 5°C	5°F	10°C	25°F
Numbers at each		10°C	20°F	5°C	10°F	20°C	50°F
Scale error, max		1°C to 300°C	2°F to 570°F	0.5°C	1°F	1°C to 260°C	2.5°F to 500°F
		1.5°C above 300°C	3°F above 570°F			2°C above 260°C	3.5°F above 500°F



**TABLE 1 Continued**

Special inscription	ASTM 8C-86 or 8F-86	160°C	ASTM 9C-86 or 9F-86 57 MM IMM	ASTM 10C-86 or 10F-86 57 MM IMM
Expansion chamber: Permit heating to				
B Total length, mm	A 380 to 390		285 to 295	285 to 295
C Stem OD, mm	6.0 to 8.0		6.0 to 7.0	6.0 to 7.0
D Bulb length, mm	10 to 15		9 to 13	7 to 10
E Bulb OD, mm	<math>\leq 5.0</math> and $\rightarrow$ stem		<math>\leq 5.5</math> and $\rightarrow$ stem	<math>\leq 4.5</math> and $\rightarrow$ stem
Scale location: Bottom of bulb to line at	32°F	0°C	32°F	90°C
F Distance, mm	30 to 40		85 to 95	80 to 90
G Length of graduated portion, mm	290 to 330 <sup>o</sup>		140 to 175 <sup>o</sup>	145 to 180 <sup>o</sup>
Ice-point scale: Range				
H Bottom of bulb to ice-point, mm				
Contraction chamber: I Distance to bottom, min, mm				
J Distance to top, max, mm				
Stem enlargement				
K OD, mm			7.5 to 8.5	7.5 to 8.5
L Length, mm			2.5 to 5.0 <sup>E</sup>	2.5 to 5.0 <sup>F</sup>
M Distance to bottom, mm			64 to 66	64 to 66

<sup>A</sup> An expansion chamber is provided for relief of gas pressure to avoid distortion of the bulb at higher temperatures. It is not for the purpose of joining mercury separations and under no circumstances should the thermometer be heated above the highest temperature reading.

<sup>C</sup> Under certain test conditions, the bulb of the thermometer may be 28°C (50°F) above the temperature indicated by the thermometer, and at an indicated temperature of 371°C (700°F) the temperature of the bulb is approaching a critical range in the glass. It is therefore not desirable to use this thermometer under such conditions at indicated temperatures above 371°C (700°F) without checking the ice point.

<sup>E</sup> The length of the enlargement, and the distance from the bottom of the enlargement to the bottom of the bulb shall be measured with the test gage shown in Fig. 1.

<sup>o</sup> Capillary clearances shall conform to Section 8.

<sup>FF</sup> For Fahrenheit thermometers, dimension G (length of graduated portion) shall be measured as the length of graduated portion corresponding to the nominal Celsius range.

IP No.	ASTM No.	11C-86	11F-86 <sup>FF</sup>	12C-98	12F-98 <sup>FF</sup>	13C-86
Name	28C			64C	64F	47C
Reference Fig. No.					Density-Wide Range	Loss on Heat
Range					4	9
For test at						155 to 170°C
A Immersion, mm					total	total
Graduations:						0.5°C
Subdivisions	2°C			0.2°C	0.5°F	1°C <sup>D</sup>
Long lines at each	10°C			1°C	1°F	155°C, 160°C, 165°C,
Numbers at each	20°C			2°C	5°F	170°C
Scale error, max	2°C to 260°C			0.15°C	0.25°F	0.5°C
	4°C above 260°C					
Special inscription					ASTM	ASTM
					12C-98 or 12F-98	13C-86
Expansion chamber: Permit heating to						200°C
B Total length, mm	A			150°C	300°F	150 to 160
C Stem OD, mm	305 to 315 <sup>NW</sup>				415 to 425	5.5 to 7.0
D Bulb length, mm	6.0 to 8.0				6.0 to 8.0	10 to 15
E Bulb OD, mm	7 to 10				15 to 20	<math>\leq 5.0</math> and $\rightarrow$ stem
Scale location: Bottom of bulb to line at	<math>\leq 4.5</math> and $\rightarrow$ stem				bulb size $\rightarrow$ stem size	
F Distance, mm	45 to 55				35 to 50	155°C
G Length of graduated portion, mm	210 to 240 <sup>o</sup>				305 to 350 <sup>o</sup>	50 to 60 40 to 60 <sup>o</sup>

**TABLE 1 Continued**

Ice-point scale:		14C-86 <sup>FF</sup>		15C-86		15F-86 <sup>FF</sup>		16C-86		16F-86 <sup>FF</sup>	
Reference Fig. No.	Range	Wax Melting Point	60C	Low Softening Point	61C	High Softening Point					
H	Bottom of bulb to ice-point, mm	38 to 82°C	7	100 to 180°F	-2 to +80°C	30 to 200°C	4	30 to 180°F	4	85 to 392°F	
I	Distance to bottom, min, mm	0.1°C	79	0.2°F	0.2°C	0.5°C	total	0.5°F	total	1°F	
J	Distance to top, max, mm	0.5°C		1°F	1°C	1°C		1°F		5°F	
K	Stem enlargement: OD, mm	1°C		2°F	2°C	5°C		5°F		10°F	
L	Length, mm	0.1°C		0.2°F	0.2°C	0.3°C		0.4°F		0.5°F	
M	Distance to bottom, mm										
<p><sup>A</sup> An expansion chamber is provided for relief of gas pressure to avoid distortion of the bulb at higher temperatures. It is not for the purpose of joining mercury separations, and under no circumstances should the thermometer be heated above the highest temperature reading.</p> <p><sup>c</sup> Under certain test conditions, the bulb of the thermometer may be 28°C (50°F) above the temperature indicated by the thermometer, and at an indicated temperature of 371°C (700°F) the temperature of the bulb is approaching a critical range in the glass. It is therefore not desirable to use this thermometer under such conditions at indicated temperatures above 371°C (700°F) without checking the ice point.</p> <p><sup>D</sup> Longest graduation lines at 155°C, 160°C, 162°C, 164°C, 165°C, and 170°C, with arrows at 162°C and 164°C.</p> <p><sup>F</sup> Long, narrow shape.</p> <p><sup>O</sup> Capillary clearances shall conform to Section 8.</p> <p><sup>FF</sup> For Fahrenheit thermometers, dimension G (length of graduated portion) shall be measured as the length of graduated portion corresponding to the nominal Celsius range.</p> <p><sup>MM</sup> This thermometer may be furnished with an optional ring top. See 6.2.3. Addition of a ring top will increase the total length by an amount equal to the outside diameter of the ring.</p>											
ASTM No.		14C-86	14F-86 <sup>FF</sup>	15C-86	15F-86 <sup>FF</sup>	16C-86	16F-86 <sup>FF</sup>				
IP No.	Name	17C		60C		61C					
Reference Fig. No.	Range	38 to 82°C	7	100 to 180°F	-2 to +80°C	30 to 200°C	4	30 to 180°F	4	85 to 392°F	
For test at	A Immersion, mm		79				total		total		
	Graduations:										
	Subdivisions	0.1°C		0.2°F	0.2°C	0.5°C		0.5°F		1°F	
	Long lines at each	0.5°C		1°F	1°C	1°C		1°F		5°F	
	Numbers at each	1°C		2°F	2°C	5°C		5°F		10°F	
	Scale error, max	0.1°C		0.2°F	0.2°C	0.3°C		0.4°F		0.5°F	
	Special inscription		ASTM				ASTM		ASTM		
			14C-86 or 14F-86			15C-86 or 15F-86		16C-86 or 16F-86			
			79 MM IMM								
Expansion chamber:											
	Permit heating to	100°C		212°F	130°C	250°C		270°F		482°F	
B	Total length, mm		370 to 380				390 to 400		390 to 400		
C	Stem OD, mm		6.0 to 8.0				6.0 to 8.0		6.0 to 8.0		
D	Bulb length, mm		18 to 28				9 to 14		9 to 14		
E	Bulb OD, mm		5.0 to 6.0				4.5 to 5.5		4.5 to 5.5		
	Scale location:										
	Bottom of bulb to line at	40°C	115 to 125	104°F	0°C	30°C	75 to 90	32°F	75 to 90	86°F	
F	Distance, mm		210 to 240 <sup>O</sup>				245 to 285 <sup>O</sup>		245 to 280 <sup>O</sup>		
G	Length of graduated portion, mm										
Ice-point scale:											
Range	Bottom of bulb to ice-point, mm										
Contraction chamber:											
	Distance to bottom, min, mm										
I	Distance to bottom, min, mm										
J	Distance to top, max, mm										
Stem enlargement:											
	OD, mm		41								
K	OD, mm										
L	Length, mm										
M	Distance to bottom, mm										

<sup>O</sup> Capillary clearances shall conform to Section 8.

<sup>FF</sup> For Fahrenheit thermometers, dimension G (length of graduated portion) shall be measured as the length of graduated portion corresponding to the nominal Celsius range.

TABLE 1 Continued

ASTM No.	17C-86	17F-86 <sup>FF</sup>	18C-86 23C	18F-86 <sup>FF</sup>	19C-86	19F-86 <sup>FF</sup>
IP No.						
Name						
Reference Fig. No.						
Range						
For test at						
A Immersion, mm	19 to 27°C 21.1 and 25°C <sup>G</sup>	66 to 80°F 70 and 77°F <sup>G</sup>	34 to 42°C 37.8°C <sup>G</sup>	94 to 108°F 100°F <sup>G</sup>	49 to 57°C 50 and 54.4°C <sup>G</sup>	120 to 134°F 122 and 130°F <sup>G</sup>
Graduations:						
Subdivisions	0.1°C	0.2°F	0.1°C	0.2°F	0.1°C	0.2°F
Long lines at each	0.5°C	1°F	0.5°C	1°F	0.5°C	1°F
Numbers at each	1°C, except 21	2°F	1°C	2°F	1°C, except 54	2°F
Scale error, max	0.1°C	0.2°F	0.1°C	0.2°F	0.1°C	0.2°F
Special inscription	ASTM 17C-86 or 17F-86		ASTM 18C-86 or 18F-86		ASTM 19C-86 or 19F-86	
Expansion chamber:						
Permit heating to						
B Total length, mm	100°C	212°F	100°C	212°F	115°C	240°F
C Stem OD, mm	270 to 280 6.0 to 7.0		270 to 280 6.0 to 7.0		270 to 280 6.0 to 7.0	
D Bulb length, mm	25 to 35		25 to 35		25 to 35	
E Bulb OD, mm	<5.0 and >stem		>stem		<5.0 and >stem	
Scale location:						
Bottom of bulb to line at						
F Distance, mm	19°C	66°F	34°C	94°F	49°C	120°F
G Length of graduated portion, mm	135 to 150 67 to 101 <sup>O</sup>		130 to 150 60 to 90 <sup>O</sup>		135 to 150 67 to 101 <sup>O</sup>	
Ice-point scale:						
Range						
H Bottom of bulb to ice-point, mm						
Contraction chamber:						
I Distance to bottom, min, mm						
J Distance to top, max, mm						
Stem enlargement:						
K OD, mm	8.0 to 10.0		8.0 to 10.0		8.0 to 10.0	
L Length, mm	4.0 to 7.0		4.0 to 7.0		4.0 to 7.0	
M Distance to bottom, mm	112 to 116		112 to 116		112 to 116	
<sup>G</sup> The test temperatures shall be indicated by an arrow whether the graduation corresponding to that point is numbered or not.						
<sup>H</sup> Long, narrow shape; mercury shall be in the chamber at 0°C (32°F).						
<sup>O</sup> Capillary clearances shall conform to Section 8.						
<sup>FF</sup> For Fahrenheit thermometers, dimension G (length of graduated portion) shall be measured as the length of graduated portion corresponding to the nominal Celsius range.						
ASTM No.	20C-86	20F-86 <sup>FF</sup>	21C-86	21F-86 <sup>FF</sup>	22C-86 24C	22F-86 <sup>FF</sup>
IP No.						
Name						
Reference Fig. No.						
Range						
For test at						
A Immersion, mm	57 to 65°C 60°C <sup>G</sup>	134 to 148°F 140°F <sup>G</sup>	79 to 87°C 82.2°C <sup>G</sup>	174 to 188°F 180°F <sup>G</sup>	95 to 103°C 98.9 and 100°C <sup>G</sup>	204 to 218°F 210°F <sup>G</sup>
Graduations:						
Subdivisions	0.1°C	0.2°F	0.1°C	0.2°F	0.1°C	0.2°F
Long lines at each	0.5°C	1°F	0.5°C	1°F	0.5°C	1°F
Numbers at each	1°C	2°F	1°C, except 82	2°F	1°C	2°F
Scale error, max	0.1°C	0.2°F	0.1°C	0.2°F	0.1°C	0.2°F
Special inscription	ASTM 20C-86 or 20F-86		ASTM 21C-86 or 21F-86		ASTM 22C-86 or 22F-86	
Expansion chamber:						
Permit heating to						
B Total length, mm	115°C	240°F	140°C	285°F	155°C	310°F
C Stem OD, mm	270 to 280 6.0 to 7.0		270 to 280 6.0 to 7.0		270 to 280 6.0 to 8.0	

**TABLE 1 Continued**

		25 to 35 ←5.0 and →stem	134°F	79°C	25 to 35 ←5.0 and →stem	174°F	95°C	25 to 35 ←5.0 and →stem	204°F
D	Bulb length, mm								
E	Bulb OD, mm								
	Scale location:								
F	Bottom of bulb to line at								
F	Distance, mm	57°C	134°F	79°C	135 to 150 67 to 101°	174°F	95°C	135 to 150 70 to 100°	204°F
G	Length of graduated portion, mm								
	Ice-point scale:								
	Range								
H	Bottom of bulb to ice-point, mm								
	Contraction chamber:								
I	Distance to bottom, min, mm								
J	Distance to top, max, mm								
K	Stem enlargement:								
K	OD, mm				60 <sup>H</sup>				60 <sup>H</sup>
L	Length, mm								
L	Distance to bottom, mm				8.0 to 10.0 4.0 to 7.0 112 to 116				8.0 to 10.0 4.0 to 7.0 112 to 116
M									

<sup>G</sup>The test temperatures shall be indicated by an arrow whether the graduation corresponding to that point is numbered or not.

<sup>H</sup>Long, narrow shape; mercury shall be in the chamber at 0°C (32°F).

<sup>O</sup>Capillary clearances shall conform to Section 8.

<sup>FF</sup>For Fahrenheit thermometers, dimension G (length of graduated portion) shall be measured as the length of graduated portion corresponding to the nominal Celsius range.

**ASTM No.**

23C-86

24C-86

25C-86

**ASTM No.**

25C-86

24C-86

25C-86

IP No.	Name	Engler Viscosity/ 7 <sup>K</sup>	Engler Viscosity/ 7 <sup>K</sup>	Engler Viscosity/ 7 <sup>K</sup>	Engler Viscosity/ 7 <sup>K</sup>
	Reference Fig. No.				
	Range				
	For test at				
A	Immersion, mm	18 to 28°C	39 to 54°C	105°C	155°C
	Graduations:	25°C	40 and 50°C	232 to 242	207 to 217
	Subdivisions	90	90	5.5 to 6.5	5.5 to 6.5
	Long lines at each			13 to 19	13 to 19
	Numbers at each			5.5 to 6.5	5.5 to 6.5
	Scale error, max	0.2°C	0.2°C	0.1°C	0.1°C
	Special inscription	1°C	1°C	2°C full figures at 40 and 50	2°C full figures at 100
		2°C full figures at 25	2°C full figures at 40 and 50	0.1°C at 40 and 50°C	0.1°C at 100°C
		ASTM	ASTM	ASTM	ASTM
		23C-86	24C-86	24C-86	25C-86
		90 MM IMM <sup>J</sup>	90 MM IMM <sup>J</sup>	90 MM IMM <sup>J</sup>	90 MM IMM <sup>J</sup>
	Expansion chamber:				
	Permit heating to				
B	Total length, mm	100°C	105°C	105°C	155°C
C	Stem OD, mm	207 to 217	232 to 242	207 to 217	207 to 217
D	Bulb length, mm	5.5 to 6.5	5.5 to 6.5	5.5 to 6.5	5.5 to 6.5
E	Bulb OD, mm	13 to 19	13 to 19	13 to 19	13 to 19
	Scale location:				
	Bottom of bulb to line at				
F	Distance, mm	18°C	39°C	39°C	95°C
G	Length of graduated portion, mm	108 to 118	108 to 118	108 to 118	108 to 118
	Ice-point scale:				
	Range	42 to 69°	67 to 94°	67 to 94°	42 to 69°
H	Bottom of bulb to ice-point, mm				
	Contraction chamber:				
I	Distance to bottom, min, mm				
J	Distance to top, max, mm				
K	Stem enlargement:				
K	OD, mm				
L	Length, mm				
M	Distance to bottom, mm				

**TABLE 1 Continued**

<sup>I</sup> The thermometer shall be made to be mounted in a brass ferrule consisting of a tubular bushing 8.0 mm in outside diameter with a flanged head approximately 12 mm in diameter so that the upper extremity of the 8.0 mm diameter is located 90 mm from the bottom of the bulb.  
<sup>J</sup> To be marked on the glass stem at least 90 mm from the bottom of the bulb.  
<sup>K</sup> Glass button finish, see 6.2.1.  
<sup>L</sup> Long, narrow shape; mercury shall be near bottom of the chamber at 0°C.  
<sup>O</sup> Capillary clearances shall conform to Section 8.

IP No.	ASTM No.	26C-86	27C-86	28C-86	28F-86 <sup>FF</sup>
Name		Stability Test of Soluble Nitrocellulose	Turpentine Distillation	31C	Kinematic Viscosity <sup>M</sup>
Reference Fig. No.	9		7		6
Range	130 to 140°C		147 to 182°C	36.6 to 39.4°C	97.5 to 102.5°F
For test at	134.5°C		76	37.8°C	100°F
A Immersion, mm	total		0.5°C		total
Graduations:			1°C	0.05°C	0.1°F
Subdivisions	0.1°C		2°C from 148	0.1 and 0.5°C	0.5 and 1°F
Long lines at each	0.5°C	1°C and in full at 130, 135, 140	ASTM	1°C	1°F
Numbers at each	0.2°C	ASTM	27C-86	0.1°C	0.2°F
Scale error, max	ASTM		76 MM IMM		ASTM
Special Inscription	26C-86		230°C		28C-86 or 28F-86
Expansion chamber:			296 to 306	105°C	
B Total length, mm	175°C		6.0 to 7.0		300 to 310
C Stem OD, mm	458 to 468		10 to 15		6.0 to 8.0
D Bulb length, mm	6.5 to 8.0		4.0 to 5.5		45 to 55
E Bulb OD, mm	54 to 67		147°C	36.6°C	> stem
Scale location:			100 to 115		145 to 165
F Bottom of bulb to line at	134.5°C		131 to 166°		40 to 90 °
G Distance, mm	320 to 340				
Length of graduated portion, mm	112 to 145°				
Ice-point scale:					
Range				-0.3 to + 0.3°C <sup>O</sup>	31.5 to 32.5°F <sup>O</sup>
H Bottom of bulb to ice-point, mm					
Contraction chamber:					
I Distance to bottom, min, mm			40 <sup>I</sup>		100
J Distance to top, max, mm	100 <sup>J</sup>				125
K Stem enlargement:					
OD, mm					
L Length, mm					
M Distance to bottom, mm					
<sup>I</sup> Long, narrow shape; mercury shall be near bottom of the chamber at 0°C. <sup>M</sup> For kinematic viscosity thermometers, the ice-point reading shall be taken within 1 h after being at the test temperature for not less than 3 minutes. The ice-point reading shall be expressed to the nearest 0.01°C or 0.02°F and applied as explained in Test Method E77, Section 13. <sup>O</sup> Capillary clearances shall conform to Section 8. <sup>FF</sup> For Fahrenheit thermometers, dimension G (length of graduated portion) shall be measured as the length of graduated portion corresponding to the nominal Celsius range.					
ASTM No.	29C-86	29F-86 <sup>FF</sup>	30F-86 <sup>FF</sup>	33C-86	33F-86 <sup>FF</sup>
IP No.	34C			20C	
Name		Kinematic Viscosity <sup>M</sup>			Low Aniline Point
Reference Fig. No.		6	6		3
Range	52.6 to 55.4°C	127.5 to 132.5°F	207.5 to 212.5°F	-38 to + 42°C	-36.5 to + 107.5°F
For test at	54.4°C	130°F	210°F		
A Immersion, mm		total	total		50
Graduations:					
Subdivisions	0.05°C	0.1°F	0.1°F	0.2°C	0.5°F
Long lines at each	0.1 and 0.5°C	0.5 and 1°F	0.5 and 1°F	1°C	1°F

**TABLE 1 Continued**

	1°C	1°F	0.2°F	ASTM	29C-86 or 29F-86	1°F	0.2°F	ASTM	30F-86	1°F	0.2°F	ASTM	33C-86 or 33F-86	50 MM IMM	2°C	0.2°C	ASTM	33C-86 or 33F-86	50 MM IMM	5°F	0.5°F	
Numbers at each Scale error, max	1°C	1°F	0.2°F	ASTM	29C-86 or 29F-86	1°F	0.2°F	ASTM	30F-86	1°F	0.2°F	ASTM	33C-86 or 33F-86	50 MM IMM	2°C <td>0.2°C <td>ASTM</td> <td>33C-86 or 33F-86</td> <td>50 MM IMM</td> <td>5°F</td> <td>0.5°F</td> </td>	0.2°C <td>ASTM</td> <td>33C-86 or 33F-86</td> <td>50 MM IMM</td> <td>5°F</td> <td>0.5°F</td>	ASTM	33C-86 or 33F-86	50 MM IMM	5°F	0.5°F	
Special inscription	0.1°C	0.2°F	ASTM	29C-86 or 29F-86	1°F	0.2°F	ASTM	30F-86	1°F	0.2°F	ASTM	33C-86 or 33F-86	50 MM IMM	2°C <td>0.2°C <td>ASTM</td> <td>33C-86 or 33F-86</td> <td>50 MM IMM</td> <td>5°F</td> <td>0.5°F</td> </td>	0.2°C <td>ASTM</td> <td>33C-86 or 33F-86</td> <td>50 MM IMM</td> <td>5°F</td> <td>0.5°F</td>	ASTM	33C-86 or 33F-86	50 MM IMM	5°F	0.5°F		
Expansion chamber:																						
Permit heating to																						
B Total length, mm	105°C	220°F	266°F	300 to 310	300 to 310	266°F	300 to 310	300 to 310	300 to 310	266°F	300 to 310	300 to 310	415 to 425	415 to 425	100°C	100°C	415 to 425	415 to 425	212°F	212°F	212°F	
C Stem OD, mm				6.0 to 8.0	6.0 to 8.0	6.0 to 8.0	6.0 to 8.0	6.0 to 8.0	6.0 to 8.0	6.0 to 8.0	6.0 to 8.0	6.0 to 8.0	6.0 to 7.5	6.0 to 7.5			6.0 to 7.5	6.0 to 7.5				
D Bulb length, mm				45 to 55	45 to 55	45 to 55	45 to 55	45 to 55	45 to 55	45 to 55	45 to 55	45 to 55	10 to 20	10 to 20			10 to 20	10 to 20				
E Bulb OD, mm				↳stem	↳stem	↳stem	↳stem	↳stem	↳stem	↳stem	↳stem	↳stem	↳stem	↳stem			↳stem	↳stem				
Scale location:																						
Bottom of bulb to line at																						
F Distance, mm	52.6°C	127.5°F	207.5°F	145 to 165	145 to 165	207.5°F	145 to 165	145 to 165	145 to 165	207.5°F	145 to 165	145 to 165	100 to 125	100 to 125	-35°C	-35°C	100 to 125	100 to 125	-31°F	-31°F	-31°F	
G Length of graduated portion, mm				40 to 90 <sup>o</sup>	40 to 90 <sup>o</sup>	40 to 90 <sup>o</sup>	40 to 90 <sup>o</sup>	40 to 90 <sup>o</sup>	40 to 90 <sup>o</sup>	40 to 90 <sup>o</sup>	40 to 90 <sup>o</sup>	40 to 90 <sup>o</sup>	240 to 280 <sup>o</sup>	240 to 280 <sup>o</sup>			240 to 280 <sup>o</sup>	240 to 280 <sup>o</sup>				
Ice-point scale:																						
Range	-0.3 to + 0.3°C <sup>o</sup>	31.5 to 32.5°F <sup>o</sup>	31.5 to 32.5°F <sup>o</sup>																			
H Bottom of bulb to ice-point, mm																						
Contraction chamber:																						
I Distance to bottom, min, mm				100	100	100	100	100	100	100	100	100	100	100			100	100				
J Distance to top, max, mm				125	125	125	125	125	125	125	125	125	125	125			125	125				
Stem enlargement:																						
K OD, mm																						
L Length, mm																						
M Distance to bottom, mm																						

<sup>M</sup> For kinematic viscosity thermometers, the ice-point reading shall be taken within 1 h after being at the test temperature for not less than 3 minutes. The ice-point reading shall be expressed to the nearest 0.01°C or 0.02°F and applied as explained in Test Method E77, Section 13.

<sup>o</sup> Capillary clearances shall conform to Section 8.

<sup>FF</sup> For Fahrenheit thermometers, dimension G (length of graduated portion) shall be measured as the length of graduated portion corresponding to the nominal Celsius range.

	34C-86	21C	34F-86 <sup>FF</sup>	35C-86	59C	35F-86 <sup>FF</sup>	36C-86
IP No.							
Name							
Reference Fig. No.							
Range	25 to 105°C		77 to 221°F	90 to 170°C		194 to 338°F	-2 to + 68°C
For test at							
A Immersion, mm							
Graduations:							
Subdivisions							
Long lines at each							
Numbers at each							
Scale error, max							
Special inscription							
Expansion chamber:							
Permit heating to							
B Total length, mm	150°C		302°F	220°C		428°F	85°C <sup>o</sup>
C Stem OD, mm			415 to 425	415 to 425		415 to 425	400 to 410
D Bulb length, mm			6.0 to 7.5	6.0 to 7.5		6.0 to 7.5	6.0 to 7.0 <sup>o</sup>
E Bulb OD, mm			10 to 20	10 to 20		10 to 20	15 to 25
Scale location:							
Bottom of bulb to line at							
F Distance, mm	25°C		77°F	90°C		194°F	-2°C
G Length of graduated portion, mm			100 to 115	100 to 115		100 to 115	50 to 60
Ice-point scale:							
Range							
H Bottom of bulb to ice-point, mm							