



Designation: **D6128 – 06 D6128 – 14**

Standard Test Method for Shear Testing of Bulk Solids Using the Jenike Shear Cell¹

This standard is issued under the fixed designation D6128; the number immediately following the designation indicates the year of original adoption or, in the case of revision, the year of last revision. A number in parentheses indicates the year of last reappraisal. A superscript epsilon (ϵ) indicates an editorial change since the last revision or reappraisal.

1. Scope*

1.1 This method² covers the apparatus and procedures for measuring the cohesive strength of bulk solids during both continuous flow and after storage at rest. In addition, measurements of internal friction, bulk density, and wall friction on various wall surfaces are included.

1.2 This standard is not applicable to testing bulk solids that do not reach the steady state requirement within the travel limit of the shear cell. It is ~~impossible~~ difficult to classify ahead of time which bulk solids cannot be tested, but one example may be those consisting of highly elastic particles.

~~1.3 The values stated in SI units are to be regarded as standard.~~

1.3 The most common use of this information is in the design of storage bins and hoppers to prevent flow stoppages due to arching and ratholing, including the slope and smoothness of hopper walls to provide mass flow. Parameters for structural design of such equipment also may be derived from this data.

1.4 All observed and calculated values shall conform to the guidelines for significant digits and rounding established in Practice D6026.

1.4.1 The procedures used to specify how data are collected/recorded or calculated, in this standard are regarded as the industry standard. In addition, they are representative of the significant digits that generally should be retained. The procedures used do not consider material variation, purpose for obtaining the data, special purpose studies, or any considerations for the user's objectives; and it is common practice to increase or reduce significant digits of reported data to be commensurate with these considerations. It is beyond the scope of this standard to consider significant digits used in analysis methods for engineering design.

~~1.5 Units—The values stated in SI units are to be regarded as standard. No other units of measure are included in this standard~~

1.6 *This standard does not purport to address all of the safety concerns, if any, associated with its use. It is the responsibility of the user of this standard to establish appropriate safety and health practices and determine the applicability of regulatory limitations prior to use.*

2. Referenced Documents

2.1 *ASTM Standards:*³

[D653 Terminology Relating to Soil, Rock, and Contained Fluids](#)

[D2216 Test Methods for Laboratory Determination of Water \(Moisture\) Content of Soil and Rock by Mass](#)

[D3740 Practice for Minimum Requirements for Agencies Engaged in Testing and/or Inspection of Soil and Rock as Used in Engineering Design and Construction](#)

[D6026 Practice for Using Significant Digits in Geotechnical Data](#)

3. Terminology

~~3.1 Definitions:~~

~~3.1.1 Definitions of terms used in this test method are in accordance with Terminology [D653](#).~~

~~3.1.2 *adhesion test, n*—a static wall friction test with time consolidation.~~

¹ This testing method is under the jurisdiction of ASTM Committee [D18](#) on Soil and Rock and is the direct responsibility of Subcommittee [D18.24](#) on Characterization and Handling of Powders and Bulk Solids.

Current edition approved Dec. 1, 2006; Sept. 1, 2014. Published January 2007; September 2014. Originally approved in 1997. Last previous edition approved in 2000; 2006 as [D6128 – 00; D6128 – 06](#). DOI: [10.1520/D6128-06](#); [10.1520/D6128-14](#).

² This test method is based on the "Standard Shear Testing Technique for Particulate Solids Using the Jenike Shear Cell," a report of the EFCE Working Party on the Mechanics of Particulate Solids. Copyright is held by the Institution of Chemical Engineers and the European Federation of Chemical Engineering.

³ For referenced ASTM standards, visit the ASTM website, [www.astm.org](#), or contact ASTM Customer Service at [service@astm.org](#). For *Annual Book of ASTM Standards* volume information, refer to the standard's Document Summary page on the ASTM website.

*A Summary of Changes section appears at the end of this standard

- 3.1.3 *angle of internal friction, ϕ_p* , *n*—the angle between the axis of normal stress (abscissa) and the tangent to the yield locus.
- 3.1.4 *angle of wall friction, ϕ'* , *n*—the arctan of the ratio of the wall shear stress to the wall normal stress.
- 3.1.5 *bin, n*—a container or vessel for holding a bulk solid, frequently consisting of a vertical cylinder with a converging hopper. Sometimes referred to as silo, bunker, or elevator.
- 3.1.6 *bulk density, ρ_b* , *n*—the mass of a quantity of a bulk solid divided by its total volume
- 3.1.7 *bulk solid, n*—an assembly of solid particles handled in sufficient quantities that its characteristics can be described by the properties of the mass of particles rather than the characteristics of each individual particle. May also be referred to as granular material, particulate solid, or powder. Examples are sugar, flour, ore, and coal.
- 3.1.8 *bunker, n*—synonym for bin, but sometimes understood as being a bin without any or only a small vertical part at the top of the hopper.
- 3.1.9 *cohesive strength, n*—synonym for unconfined yield strength.
- 3.1.10 *consolidation, n*—the process of increasing the strength of a bulk solid.
- 3.1.11 *critical state, n*—a state of stress in which the bulk density of a bulk solid and the shear stress in the shear zone remain constant.
- 3.1.12 *effective angle of friction, δ* , *n*—the inclination of the effective yield locus (EYL).
- 3.1.13 *effective yield locus (EYL), n*—straight line passing through the origin of the σ , τ -plane and tangential to the steady state Mohr circle, corresponding to steady state flow conditions of a bulk solid of given bulk density.
- 3.1.14 *elevator, n*—synonym for bin, commonly used in the grain industry.
- 3.1.15 *failure (of a bulk solid), n*—plastic deformation of an overconsolidated bulk solid subject to shear, causing dilation and a decrease in strength.
- 3.1.16 *flow, steady state, n*—continuous plastic deformation of a bulk solid at critical state.
- 3.1.17 *flow function, FF, n*—the plot of unconfined yield strength versus major consolidation stress for one specific bulk solid.
- 3.1.18 *granular material, n*—synonym for bulk solid.
- 3.1.19 *hopper, n*—the converging portion of a bin.
- 3.1.20 *major consolidation stress, σ_j* , *n*—the major principal stress given by the Mohr stress circle of steady state flow. This Mohr stress circle is tangential to the effective yield locus.
- 3.1.21 *Mohr stress circle, n*—the graphical representation of a state of stress in coordinates of normal and shear stress, that is, in the σ , τ -plane.
- 3.1.22 *normal stress, σ* , *n*—the stress acting normally to the considered plane.
- 3.1.23 *overconsolidated specimen, n*—a condition in which the shear force passes through a maximum and then decreases during preshear.
- 3.1.24 *particulate solid, n*—synonym for bulk solid.
- 3.1.25 *powder, n*—synonym for bulk solid, particularly when the particles of the bulk solid are fine.
- 3.1.26 *silo, n*—synonym for bin.
- 3.1.27 *shear test, n*—an experiment to determine the flow properties of a bulk solid by applying different states of stress and strain to it.
- 3.1.28 *shear tester, n*—an apparatus for performing shear tests.
- 3.1.29 *time angle of internal friction, ϕ_p* , *n*—inclination of the time yield locus of the tangency point with the Mohr stress circle passing through the origin.
- 3.1.30 *time yield locus, n*—the yield locus of a bulk solid which has remained at rest under a given normal stress for a certain time.
- 3.1.31 *unconfined yield strength, f_c* , *n*—the major principal stress of the Mohr stress circle being tangential to the yield locus with the minor principal stress being zero. A synonym for compressive strength.
- 3.1.32 *underconsolidated specimen, n*—a condition in which the shear force increases continually during preshear.
- 3.1.33 *wall normal stress, σ_w* , *n*—the normal stress present at a confining wall.
- 3.1.34 *wall shear stress, τ_w* , *n*—the shear stress present at a confining wall.
- 3.1.35 *wall yield locus, n*—a plot of the wall shear stress versus wall normal stress. The angle of wall friction is obtained from the wall yield locus as the arctan of the ratio of the wall shear stress to wall normal stress.
- 3.1.36 *yield locus, n*—plot of shear stress versus normal stress at failure. The yield locus (YL) is sometimes called the instantaneous yield locus to differentiate it from the time yield locus.

3.1 For common definitions of technical terms in this standard, refer to Terminology [D653](#).

4. Summary of Test Method

4.1 A representative sample specimen of bulk solid is placed in a shear cell of specific dimensions. This specimen is preconsolidated by twisting the shear cell cover while applying a compressive load normal to the cover.

4.2 When running an instantaneous or time shear test, a normal load is applied to the cover, and the specimen is presheared until a steady state shear value has been reached.

4.3 An instantaneous test is run by shearing the specimen under a reduced normal load until the shear force goes through a maximum value and then begins to decrease.

4.4 A time shear test is run similarly to an instantaneous shear test, except that the specimen is placed in a consolidation bench between preshear and shear.

4.5 A wall friction test is run by sliding the specimen over a coupon of wall material and measuring the frictional resistance as a function of normal, compressive load.

4.6 A wall friction time test involves sliding the specimen over the coupon of wall material, leaving the load on the specimen for a predetermined period of time, then sliding it again to see if the shearing force has increased.

5. Significance and Use

5.1 Reliable, controlled flow of bulk solids from bins and hoppers is essential in almost every industrial facility. Unfortunately, flow stoppages due to arching and ratholing are common. Additional problems include uncontrolled flow (flooding) of powders, segregation of particle mixtures, useable capacity which is significantly less than design capacity, caking and spoilage of bulk solids in stagnant zones, and structural failures.

5.2 By measuring the flow properties of bulk solids, and designing bins and hoppers based on these flow properties, most flow problems can be prevented or eliminated.

5.3 For bulk solids with a significant percentage of particles (typically, one third or more) finer than about 6 mm (mm, ¼ in.), the cohesive strength is governed by the fines (-6-mm fraction). For such bulk solids, cohesive strength and wall friction tests may be performed on the fine fraction only.

NOTE 1—The quality of the result produced by this test method is dependent on the competence of the personnel performing it, and the suitability of the equipment and facilities used. Agencies that meet the criteria of Practice [D3740](#) are generally considered capable of competent and objective testing/sampling/inspection/etc. Users of this test method are cautioned that compliance with Practice [D3740](#) does not in itself assure reliable results. Reliable results depend on many factors; Practice [D3740](#) provides a means of evaluating some of those factors. Practice [D3740](#) was developed for agencies engaged in the testing and/or inspection of soil and rock. As such it is not totally applicable to agencies performing this test method. However, users of this test method should recognize that the framework of Practice [D3740](#) is appropriate for evaluating the quality of an agency performing this test method. Currently there is no known qualifying national authority that inspects agencies that perform this test method.

6. Apparatus

6.1 The Jenike shear cell is shown in [Fig. 1](#). It consists of a base (1), shear ring (2), and shear lid (3), the latter having a bracket (4) and pin (5). Before shear, the ring is placed in an offset position as shown in [Fig. 1](#), and a vertical force F_v is applied to the lid, and hence, to the particulate solid within the cell by means of a weight hanger (6) and weights (7). A horizontal force is applied to the bracket by a mechanically driven measuring stem (8).

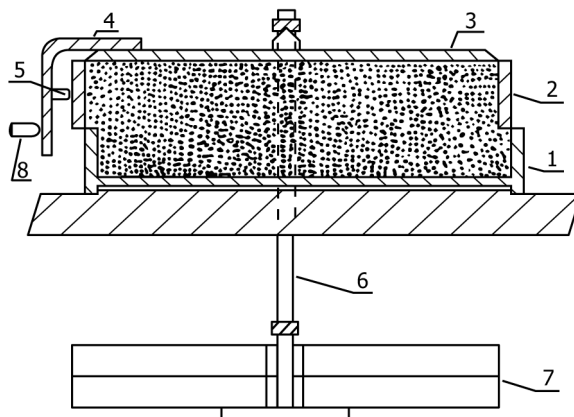

FIG. 1 Jenike Cell in Initial Offset Position

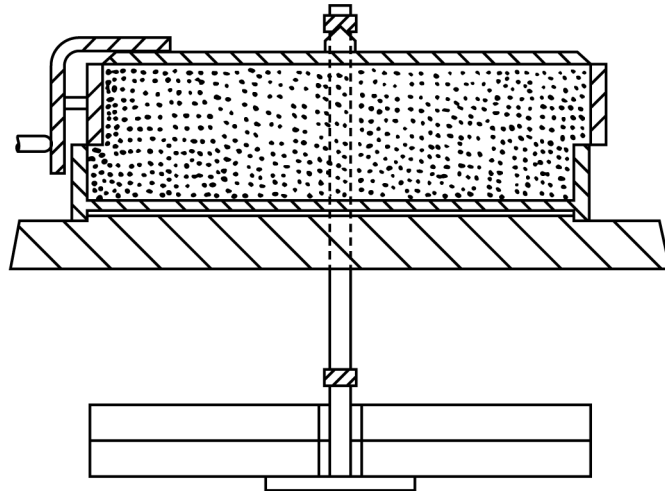

FIG. 2 Jenike Cell in Final Offset Position

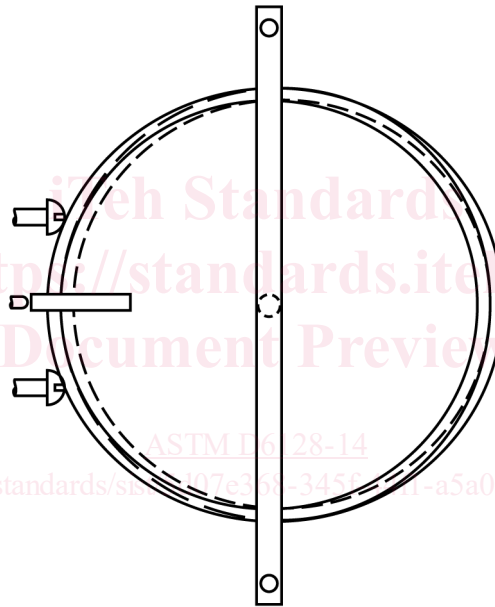

FIG. 3 Plan View of Jenike Cell Showing Offset

6.2 It is especially important that the shear force-measuring force-measuring stem acts on the bracket in the shear plane (plane between base and shear ring) and not above or below this plane.

6.3 The dimensions of the Jenike shear cells supplied by Jenike & Johanson, Inc. are given in the first two columns of the table in Fig. 4. These dimensions have been derived from English units. The standard size Jenike shear cell is made from aluminum or stainless steel, and a smaller 63-mm diameter cell made from stainless steel is also available. Since the actual dimensions are not believed to be critical, the same results could be obtained with a shear cell of the dimensions listed in the third column of the table in Fig. 4 or with other shear cells of different sizes provided that proportions of these dimensions are maintained approximately. In addition, the shear cell diameter must be at least 20 times the maximum particle size of the bulk solid being tested. Besides the shear cell, the complete shear tester includes a force transducer which measures the shear force F_s , an amplifier and a recorder, a motor driving the force-measuring force-measuring stem, a twisting wrench, a weight hanger, a time consolidation bench, an accessory for mounting wall material sample test plates, and a calibrating device. A spatula having a blade at least 50 % longer than the diameter of the shear cell, and at least a 10-mm width, is needed. The force transducer should be capable of measuring a force up to 500 N with a precision of 0.1 % of full scale. The signal from the force transducer is conditioned by an amplifier and shown on a recorder. The motor driving the force-measuring force-measuring stem advances the stem at a constant speed in the range from 1 to 3 mm/min. The original Jenike shear tester has a speed of 2.72 mm/min when the power supply is 60 Hz. As an alternative to the twisting wrench, some shear testers are supplied with a twisting device in which the twist is applied by means of a shaft passing through bearings. In this way, the likelihood of nonvertical forces or extra forces being generated during twisting is

	JENIKE STANDARD	JENIKE SMALL SIZE	STANDARD SIZE
D/mm	95.25	63.5	95
H _b /mm	12.7	9.525	13
H _r /mm	15.875	11.113	16
H _m /mm	9.525	7.938	10
T/mm	3 or greater	3 or greater	3 or greater
Material	Stainless Steel or Aluminum	Aluminum	Stainless Steel or Aluminum

GROOVES: 1 mm wide, 90° Included angle

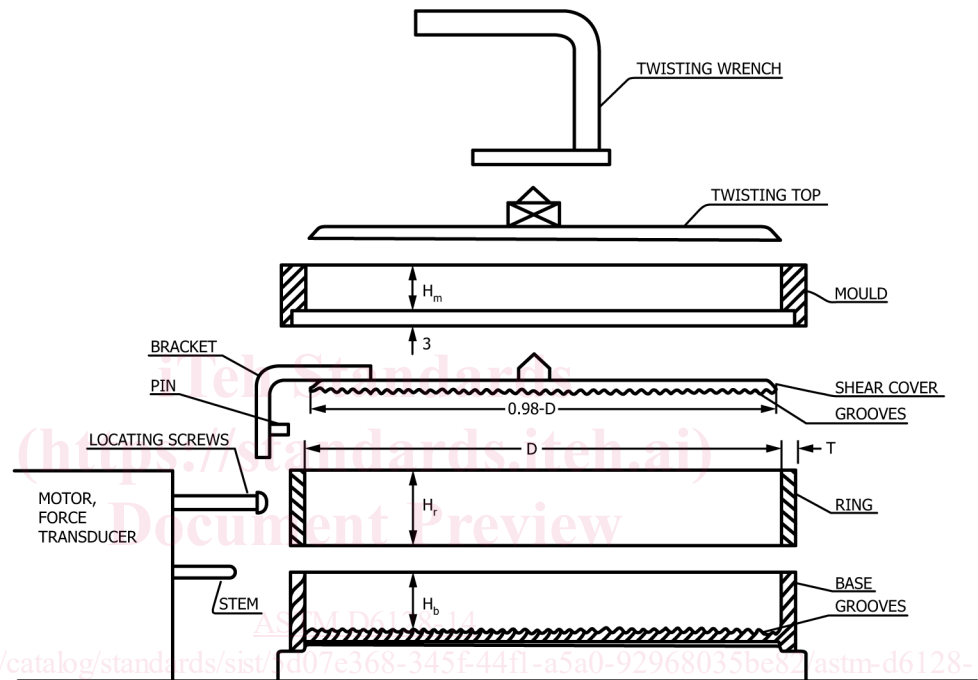

FIG. 4 Dimensions of the Jenike Cell

minimized. Another alternative is to have the motor pull the force-measuring force-measuring stem instead of pushing it. When using any such alternative methods, it is essential that the user ensure-make sure that no measurement deviations are introduced.

6.4 The consolidation bench consists of several stations for time consolidation tests. One station is shown in Fig. 5. The station is equipped with a weight carrier (14) on which the weights may be placed and a flexible cover (15) to constrain the test cell and prevent any influence from environmental effects such as evaporation or humidification during time consolidation.

6.5 The arrangement for wall friction tests is shown in Fig. 6. For these tests it is convenient to have a special shear lid with a longer pin and bracket to permit a longer shear distance. Several coupons of typical wall materials should be available. When using the standard size shear cell, each coupon should be approximately 120 mm × 120 mm.

6.6 A device for calibrating the force transducer is shown in Fig. 7. It consists of a pivot (1) around which levers of equal length, (2) and (3) rotate. With counterweight (4) the device is balanced to have its neutral position as shown in the figure. Lever (2) exerts a force to the force-measuring force-measuring stem corresponding to the weights (5) which are hung on the lever (3). The calibration curve is used to convert the recorder reading to the applied shear force.

6.7 A laboratory balance having a maximum capacity of at least 10 N with a precision of 1 % or better is required.

6.8 The laboratory used for powder testing should be free of vibrations caused by traffic or heavy machinery. Ideally, the room should be temperature and humidity controlled, or, if this is not possible, it should be maintained at its nearly constant ambient conditions. Direct sunlight, especially on the time consolidation bench, is to be avoided.

NOTE 2—Temperature- and humidity-sensitive materials may need to be tested at different temperatures and moisture contents, because this often happens in industrial environments. The laboratory environment must approximate production for meaningful testing.

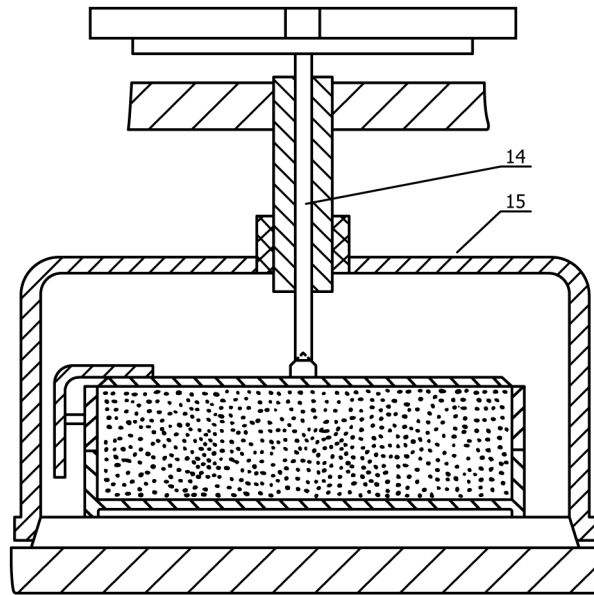

FIG. 5 Consolidating Bench Station

7. Specimen Preparation

7.1 Filling the Cell (Fig. 8):

7.1.1 Place the shear ring on the base in the offset position shown in Fig. 1 and gently press the ring with the fingers against the locating screws (10) as shown in Fig. 3 and Fig. 9. Set these screws to give an overlap of approximately 3 mm for standard cell sizes and to ensure make sure that the axis of the cell is aligned with the force-measuring force-measuring stem. Then place the mould ring (11) on the shear ring.

7.1.2 Fill the assembled cell uniformly in small horizontal layers by a spoon or spatula without applying force to the surface of the material until the material is somewhat over the top of the mould ring. The filling should be conducted in such a way as to ensure make sure that there are no voids within the cell, particularly at “a” (Fig. 8) where the ring and the base overlap. Remove excess material in small quantities by scraping off with a blade (1). The blade should be scraped across the ring in a zig-zag motion. Take care not to disturb the position of the ring on the base. For scraping, a rigid sharp straight blade should be used, and, during scraping, the blade should be tilted as shown in Fig. 8.

7.2 Preconsolidation:

7.2.1 Place the twisting or consolidation lid (12) shown in Fig. 9 on the leveled surface of the material in the mould, then place the hanger (6) on the twisting lid with weights (7) of mass m_{wtw} being hung from the hanger. See Fig. 1. Lower the lid, hanger, and weights as slowly as possible to minimize aerated material being ejected from the cell.

7.2.2 Visually observe the vertical movement of the lid as the material of the cell is compressed. Wait until this movement appears to stop.

7.2.3 Remove the weights, hanger, and twisting lid. Fill and level the space above the compressed material as during filling.

NOTE 3—As will be mentioned later, this refilling procedure may not be necessary at all or may need to be performed several times, depending on the compressibility of the powder being tested. This operation determines what height of compacted material will have to be scraped off the ring after twisting.

7.3 Twisting:

7.3.1 Place the twisting lid (12) with a smooth bottom surface on the leveled surface of material in the mould after filling or refilling. Place the hanger with weights of m_{wtw} on the twisting lid. The weights on the hanger should correspond to a pressure of σ_{tw} , approximately equal to σ_p .

7.3.2 Empty the cell and repeat the filling operation if the surface of material in the cell does not appear to the naked eye to be level.

7.3.3 Having filled the cell, the twisting lid is usually twisted through 20 cycles by means of the twisting wrench (spanner) (13) or twisting device. Each twisting cycle consists of a 90° rotation of the lid which is then reversed. Care must be taken not to apply vertical forces to the lid during twisting. While twisting, press the ring against the locating screws with the fingers to prevent it from sliding from its original offset position.

NOTE 4—The mould and ring should be allowed to rotate freely and independently of each other. The rotation of the ring may be small but has an influence on the consolidation.

7.3.4 If the shear apparatus is not fitted with a special twisting device, the twisting is performed by holding the wrench in one hand and using the thumb and forefinger of the other to maintain the ring in the offset position against the locating screws (2) shown

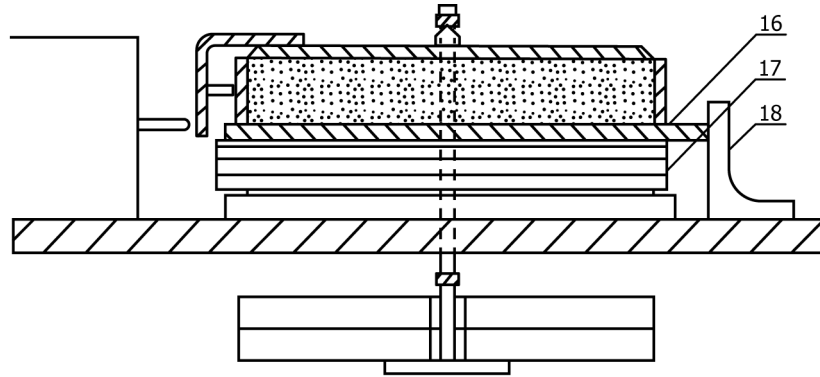

FIG. 6 Wall Friction Test

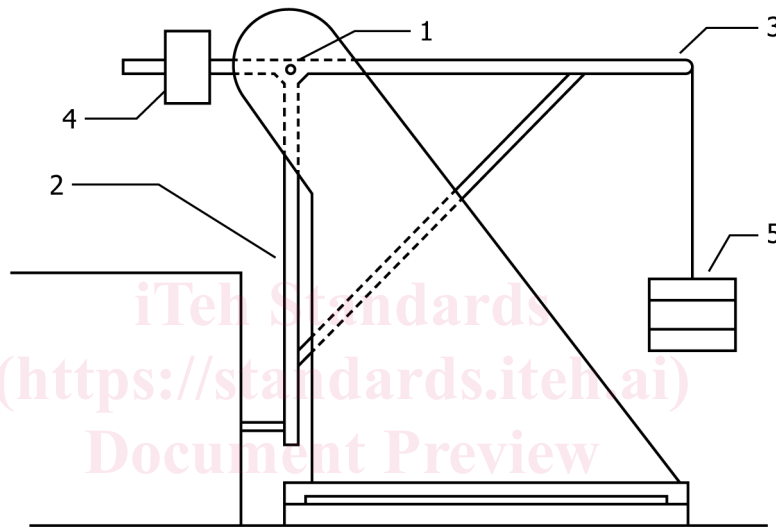

FIG. 7 Calibration Device

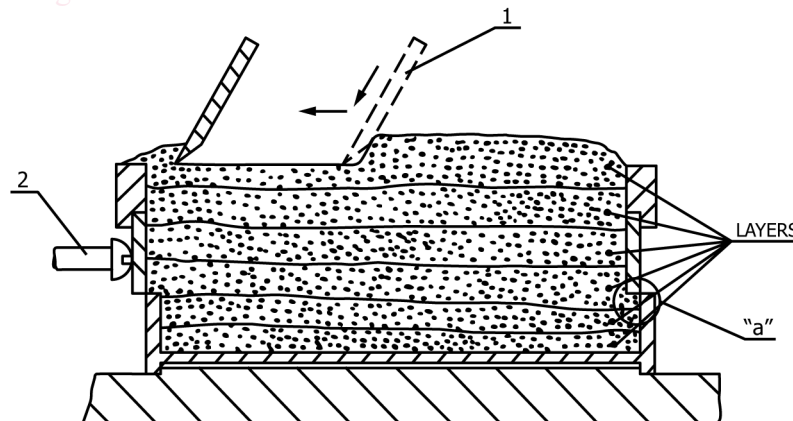

FIG. 8 Scraping Off Excess Powder

in Fig. 8. The twisting operation should be smooth and continuous, without jerks, and at the rate of about one twist per second. It is useful to mark the shear cell or twisting device to ensure make sure of a 90° rotation. After twisting, carefully remove the weights and hanger, then hold the lid in position by light finger pressure and carefully remove the mold-mold. Slide the lid off the material in the cell, sliding it in the direction of the force-measuring force-measuring stem so that the shear ring is kept pressed in position against the locating screws.

NOTE 5—The compacted material above the ring should be evenly distributed if the filling has been satisfactory. The material remaining above the ring after twisting should be from 1 to about 3 mm thick.

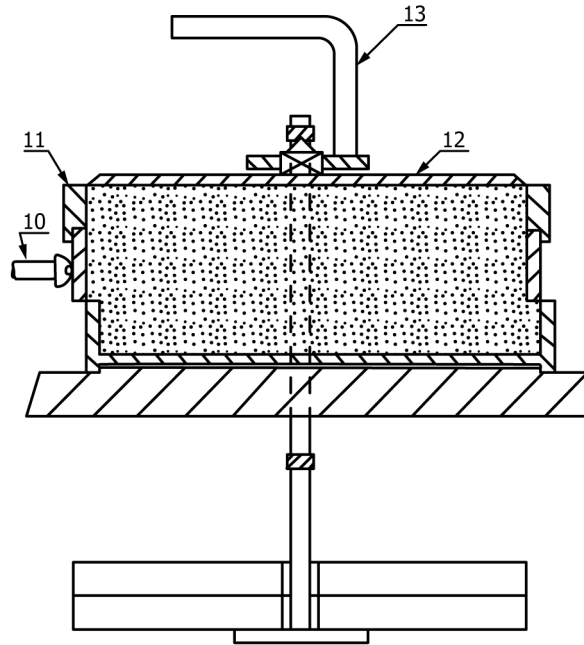

FIG. 9 Jenike Cell With Mold Ring and Consolidation Lid

7.3.5 Discard the test specimen and prepare a new one if, after twisting, the material surface is below the top of the ring.

7.3.6 Scrape off excess material in small quantities to be flush with the top of the ring using a blade in the same way as that shown in Fig. 8. Do not exert downward force by the scraping blade.

NOTE 6—If coarse particles are present, scraping may tear them from the surface and alter the structure. In such cases, it is better to attempt to fill the cell so that the material surface is flush with the ring after consolidation. Care must again be taken not to displace the shear ring from its original offset position.

8. Procedure

8.1 Shear Testing Procedure:

8.1.1 Synopsis:

8.1.1.1 Place the shearing lid centrally on the leveled surface of material with the pin of the bracket within 1 mm of the ring. Make sure that the bracket of the shear lid is in line with the force-measuring force-measuring stem. Place weights m_{WP} corresponding to σ_p on the hanger, and gently lower the hanger with weights as slowly as possible onto the shear lid so as to not jar the specimen. Steady the hanger to prevent any visible swinging motion. Switch on the motor driving the force-measuring force-measuring stem, and perform a shear test for the full shear distance of approximately 6 mm from the offset position in Fig. 1 to the offset position in Fig. 2 for standard cell sizes. Record the shear force, F_s , for the whole shear distance.

NOTE 7—During shear, a shear zone develops in the specimen of particulate solid in the cell. Since the stem advances at a steady rate, the record of shear force versus time can be transformed into a shear force – shear strain plot.

8.1.1.2 Inspect the shear force – shear strain plot. If the specimen is found to be ~~underconsolidated, under-consolidated,~~ or ~~overconsolidated, over-consolidated,~~ remove the specimen and repeat the procedure beginning at 7.1. If the specimen is found to be ~~underconsolidated, under-consolidated,~~ increase the number of twists applied to the lid, then increase the weight m_{Wtw} in accordance with A3.10. If the specimen is ~~overconsolidated, over-consolidated,~~ decrease the number of twists, then reduce the weight m_{Wtw} in accordance with A3.11.

NOTE 8—In such a manner, it is possible by trial and error, to find a combination of weight, m_{Wtw} , and the number of twists so that for the selected weight, m_{WP} , the shear force – shear strain plot indicates the presence of a critically consolidated specimen. This operation is called optimization. See Annex A3.

NOTE 9—Each shear test gives one point on a yield locus and consists of preshear and shear. Changes in the preconsolidation procedure may affect the yield locus derived from this test.

NOTE 10—The force measuring stem measures the shear force in the shear plane between the base and ring, and hence, the corresponding normal force has to be determined in this plane. In the Jenike shear cell this normal force, F_v , is a vertical force produced by the combined masses of:

- Weights, m_W
- Hanger, m_H
- Shear Lid, m_L
- Ring, m_R
- Material in the shear ring above the shear plane, m_B

NOTE 11—The shear ring is included in the vertical force since during shear the material dilates in the shear zone, as a result of which all material above the shear plane is lifted slightly. Since the material is constrained in the shear ring, any dilation of the cell contents brings about a lifting of the ring such that the weight of the ring is supported by the material in the ring rather than by the cell base. For preshear, this is not strictly so, because part of the weight of the ring may be transferred to the base. Therefore, because during preshear that portion of the weight of the ring transferred to the base is uncertain, the weight of the ring is included in the weights contributing towards the total normal force when calculating the preshear normal force. The influence of the ring-base contact on the shear and normal force can be avoided by carefully lifting the shear ring less than 1 mm and twisting it through a couple of degrees prior to shear while the shear lid has a weight applied to it.

8.1.1.3 The force-measuring stem measures the shear force in the shear plane between the base and ring, and hence, the corresponding normal force has to be determined in this plane. In the Jenike shear cell this normal force, F_v , is a vertical force produced by the combined masses of:

- Weights, m_w
- Hanger, m_H
- Shear Lid, m_L
- Ring, m_R
- Material in the shear ring above the shear plane, m_B

NOTE 10—The shear ring is included in the vertical force since during shear the material dilates in the shear zone, as a result of which all material above the shear plane is lifted slightly. Since the material is constrained in the shear ring, any dilation of the cell contents brings about a lifting of the ring such that the weight of the ring is supported by the material in the ring rather than by the cell base. For preshear, this is not strictly so, because part of the weight of the ring may be transferred to the base. Therefore, because during preshear that portion of the weight of the ring transferred to the base is uncertain, the weight of the ring is included in the weights contributing towards the total normal force when calculating the preshear normal force. The influence of the ring-base contact on the shear and normal force can be avoided by carefully lifting the shear ring less than 1 mm and twisting it through a couple of degrees prior to shear while the shear lid has a weight applied to it.

8.1.2 Preshear:

8.1.2.1 The first part of the shear test consists of preparing a critically consolidated specimen by optimized twisting and then preshearing the specimen with a selected weight, m_{wp} , to develop a shear zone in which steady state flow occurs.

8.1.2.2 Select the first preshear normal stress, $\sigma_{p,1}$, on the basis of the bulk density of the test material, in accordance with the following table:

ρ_b (kg/m ³)	$\sigma_{p,1}$ (kPa)
< 300	approximately 1.5
300 to 800	approximately 2.0
800 to 1600	approximately 2.5
1600 to 2400	approximately 3.0
> 2400	approximately 4.0

8.1.2.3 A preliminary estimate of the bulk density can be made by placing the shear ring on a flat surface, packing the particulate solid in the ring with fingers, scraping the solid level with the top, and weighing the contained solid. From the weights/masses and volume of the specimen, calculate the bulk density.

8.1.2.4 At the selected preshear normal stress prepare a nearly critically consolidated specimen and start preshear. The shear stress rises (Fig. 10) and attains the steady state value τ_p . Maintain this shear stress in the shear cell through a relatively short shear

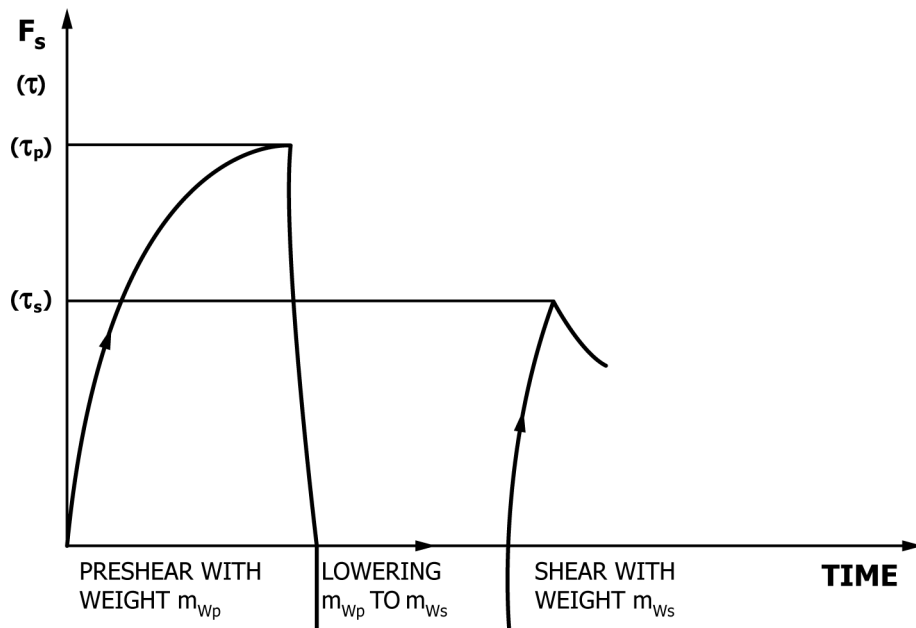

FIG. 10 Stress-Strain Curves — Preshear and Shear

distance (about 0.5 mm) to ascertain this value.

NOTE 11—The steady state shear stress τ_p may be attained after relatively little shear, even before the shear ring and base completely overlap. With some materials a greater amount of shear may be necessary to attain steady state shear. However, the steady state shear stress should be attained after a maximum shear distance corresponding to three fourths of the total available.

8.1.2.5 Constancy of the values of the steady state shear stress τ_p obtained after preshear is an indication of the reproducibility of consolidation. With correctly consolidated ~~samples, specimens,~~ individual values of the steady state shear stress should not deviate by more than $\pm 5\%$ from the average steady state shear stress for the given preshear normal stress. With some particulate solids, however, this tolerance cannot be achieved. If this happens, it should be noted by the technician performing the test.

8.1.3 Shear:

8.1.3.1 Having attained a steady state flow condition, reverse the forward motion of the ~~force measuring~~ force-measuring stem until the stem loses contact with the bracket, that is, the shear force falls to zero, (Fig. 10). For the second stage select a shear normal stress level σ_s within the range of 25 to 80 % of the preshear normal stress level σ_p , and replace the weight m_{wp} by a smaller weight m_{ws} . Switch on the motor again to drive the measuring stem in the forward direction.

NOTE 12—When the stem touches the bracket, the shear force rapidly increases, goes through a maximum representing the yield shear force, and then begins to decrease. This part of the test is called shear.

NOTE 13—Shear may be continued until the whole overlap distance of the cell has been traversed in order to develop a distinct shear plane. The value τ_s is the shear stress at failure peak (shear point) for the selected shear normal stress σ_s at the selected preshear normal stress σ_p . When reducing the normal stress before shear, it is recommended that weights be removed from the hanger until the required weight is left. If the test is to be carried out at low shear, and hence low normal stress levels, it may be necessary to remove the hanger and place the weights directly on the lid. Whichever procedure is followed, the weights should be removed and replaced in a gentle manner.

8.1.3.2 After each shear test, calculate the overall bulk density of the specimen by determining the mass of the specimen with the base, shear ring, and shear lid.

NOTE 14—Since the mass of base, ring, and lid are known and also the volume of the cell can be determined, the overall bulk density, ρ_b , of the specimen can be calculated. The value of the bulk density of the specimen after the shear test gives an indication of the reproducibility of specimen preparation.

8.1.3.3 After each shear test (and weighing), lift the shear ring with shear lid and material contained within the ring from the base and inspect the plane of failure.

8.1.3.4 If the plane of failure cuts diagonally across the particulate solid either up to the shear lid or down to the bottom of the base, the test is invalid and will have to be repeated.

NOTE 15—If an invalid plane of failure persists, further tests at the given and lower shear normal stress levels cannot be performed and shear tests can be made only at higher shear normal stresses. In such a case, the intervals between the shear normal stress levels may have to be reduced to obtain the necessary minimum of three shear points on the yield locus. If the material is free flowing it may be impossible to observe the plane of failure.

8.1.4 Additional Tests:

8.1.4.1 Repeat 7, 8.1.2 and 8.1.3.

8.1.4.2 Select 3 to 5 shear normal stress levels σ_s within the range of 25 to 80 % of the preshear normal stress level σ_p , and repeat 7, 8.1.2.4, 8.1.3, and 8.1.4.1.

8.1.4.3 Select higher preshear normal stress levels so that:

$$\begin{aligned}\sigma_{p,2} &= 2\sigma_{p,1} \\ \sigma_{p,3} &= 4\sigma_{p,1} \\ \sigma_{p,4} &= 8\sigma_{p,1}\end{aligned}$$

NOTE 16—Some adjustment in preshear normal stress levels may be necessary in order to cover the range of major consolidation stresses σ_1 necessary to accurately calculate critical arching and/or ratholing dimensions.

8.1.4.4 Repeat 7, 8.1.2, 8.1.3, and 8.1.4.2 for each selected preshear normal stress level.

8.1.5 Prorating:

8.1.5.1 Ideally, all values of the preshear shear stress, τ_p , for a given preshear normal stress would be identical. This would occur if the specimen was perfectly homogeneous, and specimen preparation completely repeatable. However, because of unavoidable experimental variation there is a scatter of τ_p values which affects the value of the shear stress, τ_s .

8.1.5.2 To minimize the scatter, all measured shear stresses, τ_s , may be corrected to take into account scatter in the preshear shear stresses, τ_p . This empirical procedure is called prorating, and prorated values of τ'_s of the measured values τ_s are evaluated using the following equation:

$$\tau'_s = \tau_s \frac{\bar{\tau}_p}{\tau_p} \quad (1)$$

where $\bar{\tau}_p$ average of the preshear, shear stresses, τ_p , of the corresponding preshear normal stress level (yield locus). Prorating assumes that variations in consolidation produce variations in shear stress, τ_s , that are proportional to the corresponding variation in preshear shear stress, τ_p .

8.1.6 Determination of Valid Shear Points: