

---

International Standard



3511/4

---

INTERNATIONAL ORGANIZATION FOR STANDARDIZATION • МЕЖДУНАРОДНАЯ ОРГАНИЗАЦИЯ ПО СТАНДАРТИЗАЦИИ • ORGANISATION INTERNATIONALE DE NORMALISATION

---

**Industrial process measurement control functions and instrumentation — Symbolic representation —  
Part 4: Basic symbols for process computer, interface, and shared display/control functions**

**iTeh STANDARD PREVIEW**

*Fonctions de régulation, de mesure et d'automatisme des processus industriels — Représentation symbolique —  
Partie 4: Symboles de base pour la représentation des fonctions calculateur*

(standards.iteh.ai)

First edition — 1985-08-15

[ISO 3511-4:1985](https://standards.iteh.ai/catalog/standards/sist/55eade8e-1d02-4861-8a50-bc0a2b3efe60/iso-3511-4-1985)

<https://standards.iteh.ai/catalog/standards/sist/55eade8e-1d02-4861-8a50-bc0a2b3efe60/iso-3511-4-1985>



---

UDC 744.43 : 62-52 : 003.62

Ref. No. ISO 3511/4-1985 (E)

**Descriptors :** technical drawing, graphic symbols, control functions, measuring instruments, control devices, adjusting systems.

## Foreword

ISO (the International Organization for Standardization) is a worldwide federation of national standards bodies (ISO member bodies). The work of preparing International Standards is normally carried out through ISO technical committees. Each member body interested in a subject for which a technical committee has been established has the right to be represented on that committee. International organizations, governmental and non-governmental, in liaison with ISO, also take part in the work.

Draft International Standards adopted by the technical committees are circulated to the member bodies for approval before their acceptance as International Standards by the ISO Council. They are approved in accordance with ISO procedures requiring at least 75 % approval by the member bodies voting.

International Standard ISO 3511/4 was prepared by Technical Committee ISO/TC 10, *Technical drawings*.

This part of ISO 3511 was developed by sub-committee 3, *Graphical symbols for instrumentation*. The symbols are intended to be used to represent functions and, in special cases, equipment on technical drawings such as schematic diagrams or process flow-diagrams. However, this field of engineering is closely related to electrical instrumentation dealt with by IEC/TC 65 or in part by IEC/SC 3A. For this reason there has been close coordination in a joint working group and the results were accepted by members of ISO and IEC.

# Industrial process measurement control functions and instrumentation — Symbolic representation — Part 4: Basic symbols for process computer, interface, and shared display/control functions

## 0 Introduction

This International Standard has been devised to provide a universal means of communication between the various interests involved in the design, manufacture, installation and operation of measurement and control equipment used in the process industries.

Requirements within the industries vary considerably; in recognition of this, this International Standard is presented in four parts as follows:

Part 1: Basic requirements (directed towards the needs of those employing comparatively simple measurement and control means).

Part 2: Extension of basic requirements.

Part 3: Detailed symbols for instrument interconnection diagrams.

Part 4: Basic symbols for process computer, interface functions, and shared display/control functions.

These parts together are intended to

- a) meet the requirements of those who, possibly employing more sophisticated measurement and control means, may wish to depict such aspects as the measurement techniques embodied in a particular instrument, or the means — hydraulic, pneumatic, electrical, mechanical — used for its actuation;
- b) provide standard symbolic representation for process measurement control functions and instrumentation. These symbols are not intended to replace graphical symbols for electrical equipment as contained in IEC Publication 617, *Graphical symbols for diagrams*.

## 1 Scope and field of application

The symbols established in this part of ISO 3511 have been developed to be used in conjunction with the symbols given in ISO 3511/1 and ISO 3511/2 and shall be considered as supplementary.

They are intended to provide a means of illustrating process computer and/or shared display/control functions in the field of process measurement and control and may be used with the symbols of ISO 3511/1 and ISO 3511/2. They will enable users to show and identify in simple form the functions of instruments, the process computer, and shared display/control functions, or any combination of these.

It is permissible to use the basic symbol for computer-based functions (see 3.1) throughout for any software-based digital system. This is not intended to preclude the use of the basic symbol for shared display/control functions (see 3.2) if the user considers this to be appropriate.

The symbols are intentionally limited to identification on process flow diagrams, piping and instrument diagrams, etc. and do not provide a means of illustrating specific instruments or parts thereof.

The letter code for function identification shall be taken from table 1 of ISO 3511/1 and ISO 3511/2.

The application methods are shown in the examples.

## 2 Definitions

For the purposes of this part of ISO 3511, the following definitions and the definitions given in ISO 3511/1 and ISO 3511/2 apply.

**2.1 programmable:** Term indicating the capability of the system to accept instructions in computer language given by the user for performing control strategies or complex functions.

**2.2 configurable:** Term indicating the capability of the system to allow the user to select, from pre-programmed functions (modular software units), those which are necessary to accomplish a control strategy or other complex functions, without the use of computer language.

**2.3 process computer:** Programmable device which operates in real time on process data, on-line (primarily sensor-based), to perform user specifiable supervision and/or control functions.

**2.4 shared display/shared control system:** System in which shared functions, such as display, control and communications, are shared in time, i.e. "time-shared" functions. These functions are generally accomplished by devices containing pre-programmed algorithms which are user accessible, configurable and connectable to perform a given control strategy or function.

**2.5 distributed control system (DCS):** System for process control purposes which, while being functionally integrated, consists of sub-systems which may be physically separated and remotely located from one another. These sub-systems are normally connected by a communication link (e.g. data bus).

**2.6 software link:** Interconnection of system functions via keyboard or program instructions (soft wiring as opposed to hard wiring).

### 3 Basic symbols

#### 3.1 Basic symbol for computer-based functions

The symbol comprises

- a thin line hexagon of approximately 10 mm width between two parallel sides [see figure 1a)];

- a letter code in accordance with ISO 3511/1 and ISO 3511/2 denoting the process computer functions.

If required, a number may be included to make identification easier.

If only computer functions are provided, the basic symbol alone may be used [see figure 1b)].

The basic symbol is usually applied in conjunction with the basic symbols of ISO 3511/1 and ISO 3511/2 showing measured process variables or actuated correcting unit [see figure 1c)].

Symbols which touch each other imply communication between functions.

#### NOTES

- 1 An acceptable alternative symbol, used by some countries, is the thin line half-circle. Several examples of this usage are shown for reference in clause 4.
- 2 The single horizontal line (see ISO 3511/1) should be used to indicate the existence of operator interface in the control room.
- 3 The double horizontal line (see ISO 3511/2) should be used to indicate accessibility at a local panel.
- 4 This symbol is intended to represent computer and interface functions performed by a programmable device.



<https://standards.iteh.ai/catalog/standards/sist/55eade8e-1d02-4861-8a50-b00a2b3e360/iso-3511-4-1985>  
 (standards.iteh.ai)

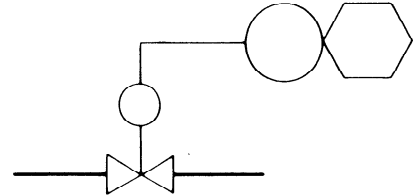
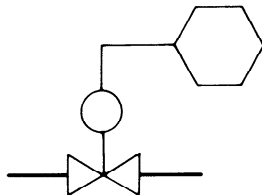
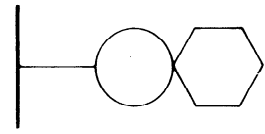
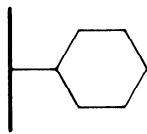
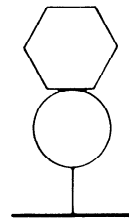

a) Basic symbol

b) Symbol for process computer only

c) Symbol in connection with instruments

Figure 1

### 3.2 Basic symbol for shared display/control functions

The symbol comprises

- a thin line circle of approximately 10 mm in diameter set inside a square [see figure 2a)];
- a letter code in accordance with ISO 3511/1 and ISO 3511/2 denoting the shared display/control functions.

If required, a number may be included to make identification easier.

If only shared display/control functions are provided, the basic symbol alone may be used [see figure 2b)].

The basic symbol is usually applied in conjunction with the basic symbols of ISO 3511/1 and ISO 3511/2 showing measured process variables or actuated correcting unit [see figure 2c)].

Symbols which touch each other imply communication between functions.

#### NOTES

- 1 The basic symbol is not rotatable.
- 2 The single horizontal line (see ISO 3511/1) should be used to indicate the existence of operator interface.
- 3 The double horizontal line (see ISO 3511/2) should be used to indicate accessibility at a local panel.
- 4 This symbol is intended to represent functions performed by a configurable device with shared functions for display and/or control.

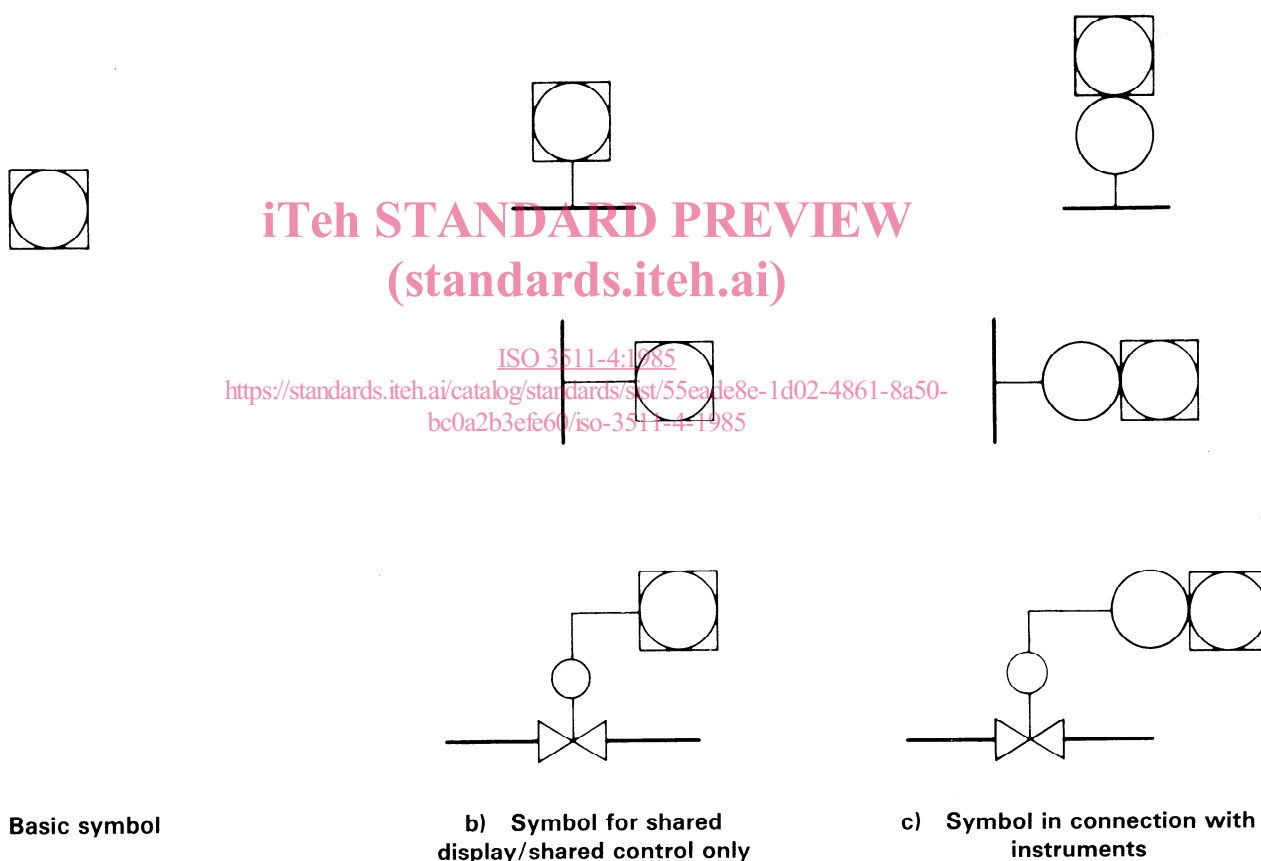
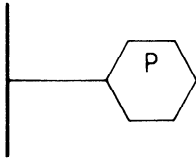

Figure 2

4 Examples of use of the symbols

4.1 Process computer examples

4.1.1 Pressure signal to computer



Alternative method

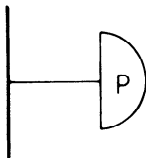

4.1.3 Flow recording and control by computer

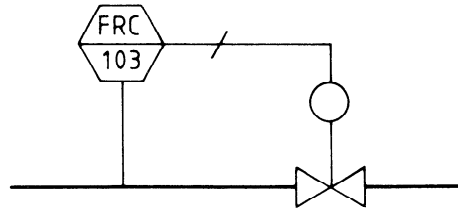

4.1.4 Control valve actuated and position display (open-shut) on computer

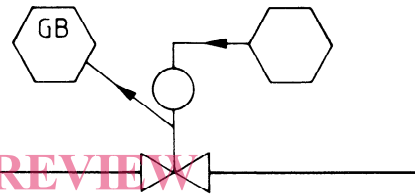

iTeh STANDARD PREVIEW

4.1.2 Temperature signal to computer (input number 211) with temperature recording and high alarm by computer normally accessible to the operator

ISO 3511-4:1985 Alternative method

<https://standards.iteh.ai/catalog/standards/sist/55eade8e-1d02-4861-8a50-bc0a2b3efe60/iso-3511-4-1985>

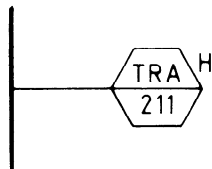

Alternative method

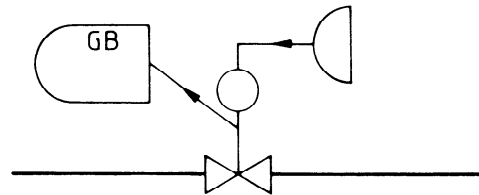
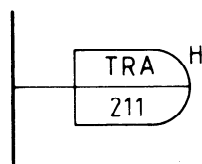

4.1.5 Flow recording and control by computer, flow indication in control room

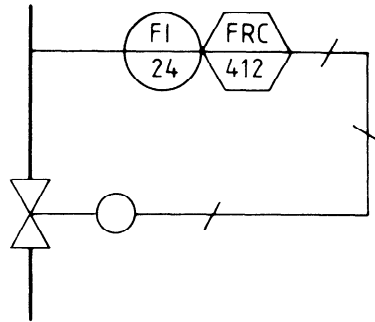

4.1.6 Pressure recording and control by computer with "back-up" by discrete instruments

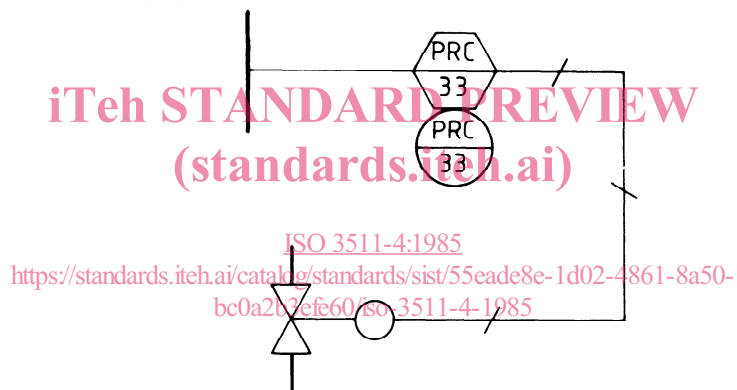

4.1.7 Flow recording and control by computer, operator access in local control room, flow indication in central control room

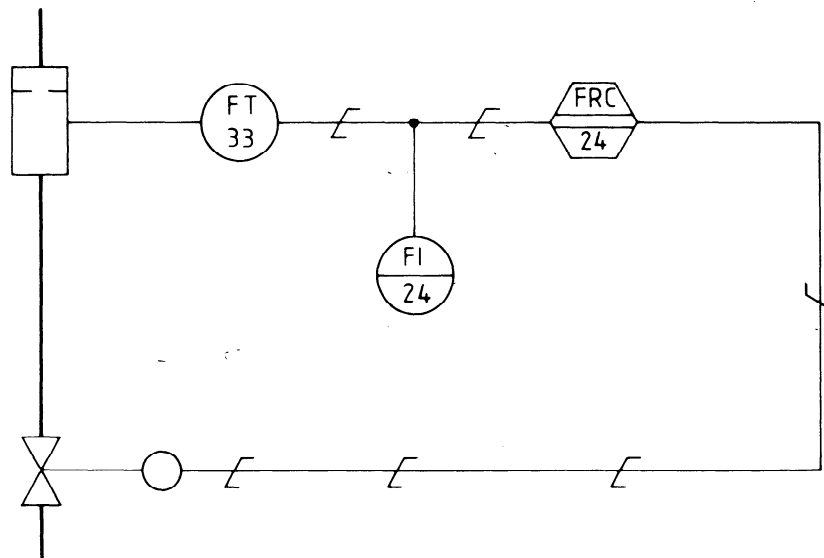

4.1.8 Cascade control and indication and recording of temperature by computer with "back-up" control and indication with common process connections

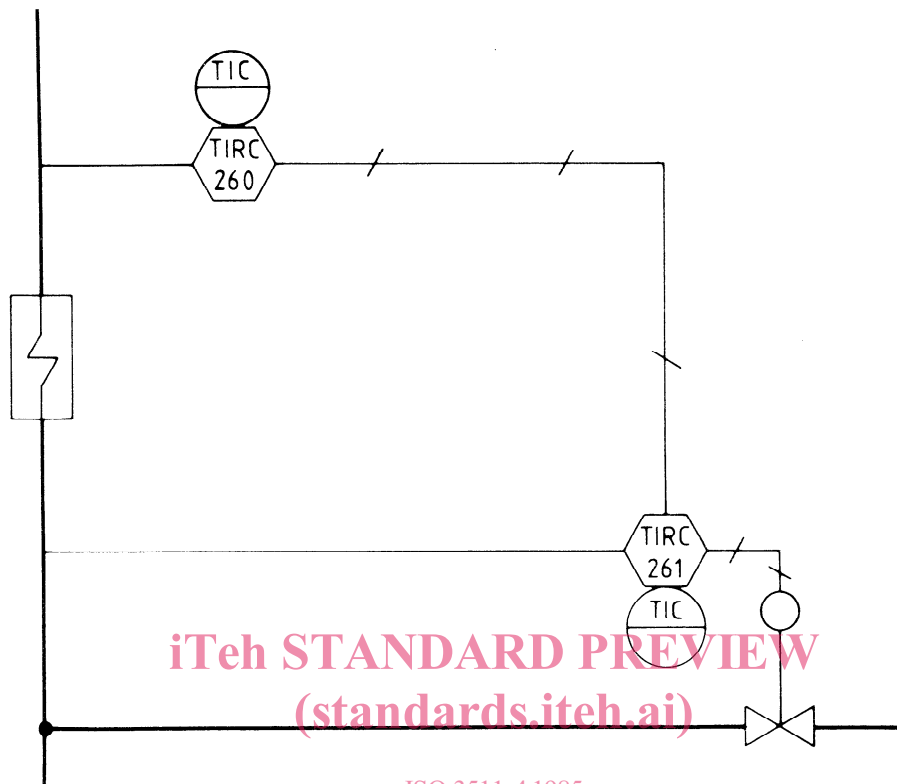

ISO 3511-4:1985  
<https://standards.iteh.ai/catalog/standards/sist/55eade8e-1d02-4861-8a50-bc0a2b3efe60/iso-3511-4-1985>

Alternative method

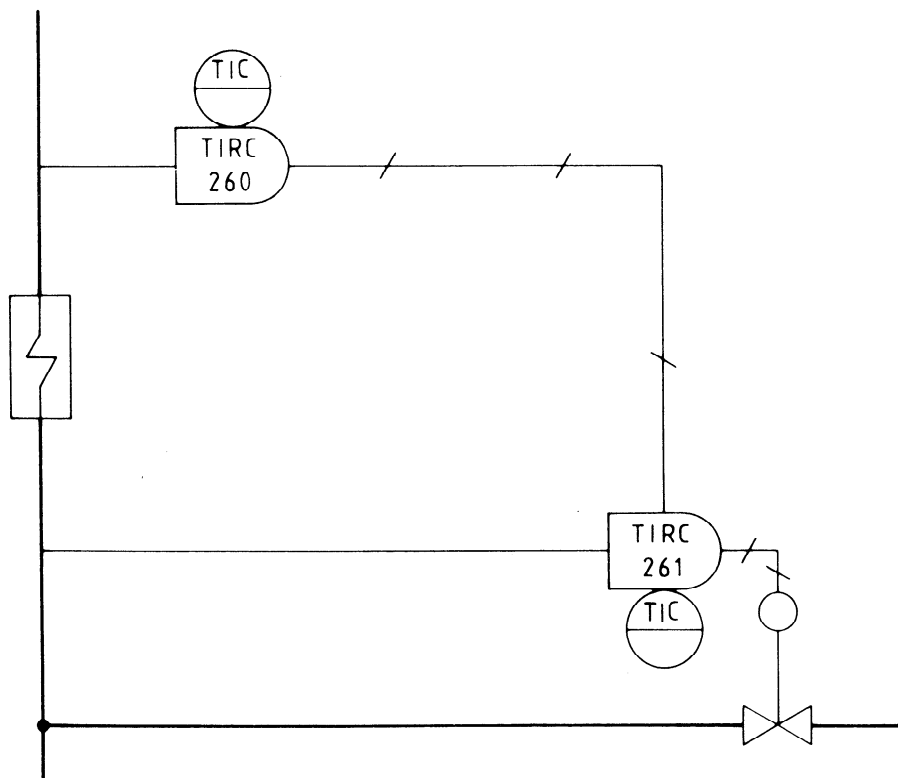



4.1.9 Indication and cascade control of level to flow by computer, with connected "back-up" control and indication

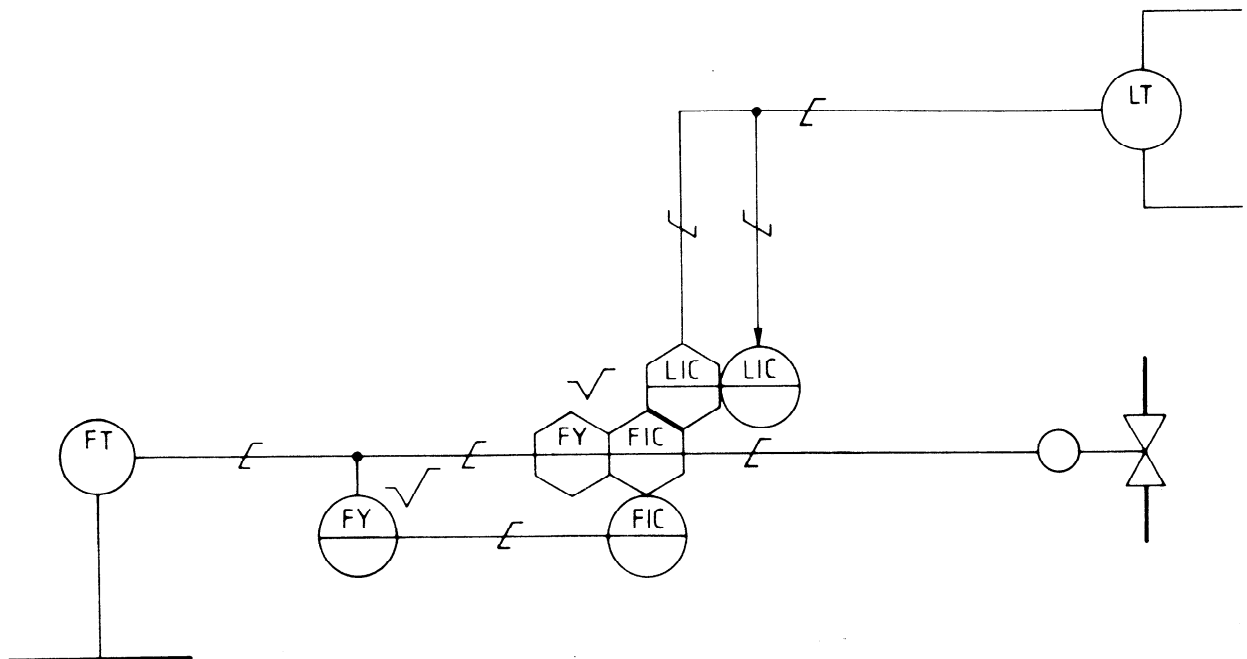

iTeh STANDARD PREVIEW  
(standards.iteh.ai)

4.2 Shared display/control examples [ISO 3511-4:1985](https://standards.iteh.ai/catalog/standards/sist/55eade8e-1d02-4861-8a50-bc0a2b3efe60/iso-3511-4-1985)

[https://standards.iteh.ai/catalog/standards/sist/55eade8e-1d02-4861-8a50-](https://standards.iteh.ai/catalog/standards/sist/55eade8e-1d02-4861-8a50-bc0a2b3efe60/iso-3511-4-1985)

4.2.1 Flow recording on shared display [bc0a2b3efe60/iso-3511-4-1985](https://standards.iteh.ai/catalog/standards/sist/55eade8e-1d02-4861-8a50-bc0a2b3efe60/iso-3511-4-1985)

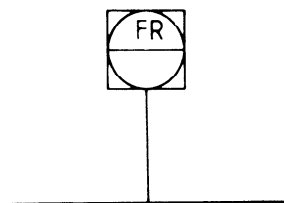

4.2.2 Shared control and recording of pressure, i.e. by distributed control system (DCS) with pressure recording by a discrete instrument in control room

