



Designation: C1419 – 14

# Standard Test Method for Sonic Velocity in Refractory Materials at Room Temperature and Its Use in Obtaining an Approximate Young's Modulus<sup>1</sup>

This standard is issued under the fixed designation C1419; the number immediately following the designation indicates the year of original adoption or, in the case of revision, the year of last revision. A number in parentheses indicates the year of last reapproval. A superscript epsilon ( $\epsilon$ ) indicates an editorial change since the last revision or reapproval.

## 1. Scope

1.1 This test method describes a procedure for measuring the sonic velocity in refractory materials at room temperature. The sonic velocity can be used to obtain an approximate value for Young's modulus.

1.2 The sonic velocity may be measured through the length, thickness, and width of the specimen.

1.3 The values stated in SI units are to be regarded as standard. No other units of measurement are included in this standard.

1.4 *This standard does not purport to address the safety concerns, if any, associated with its use. It is the responsibility of the user of this standard to establish appropriate safety and health practices and determine the applicability of regulatory limitations prior to use.*

## 2. Referenced Documents

2.1 *ASTM Standards:*<sup>2</sup>

C134 Test Methods for Size, Dimensional Measurements, and Bulk Density of Refractory Brick and Insulating Firebrick

C179 Test Method for Drying and Firing Linear Change of Refractory Plastic and Ramming Mix Specimens

C769 Test Method for Sonic Velocity in Manufactured Carbon and Graphite Materials for Use in Obtaining Young's Modulus

C885 Test Method for Young's Modulus of Refractory Shapes by Sonic Resonance

E177 Practice for Use of the Terms Precision and Bias in ASTM Test Methods

E691 Practice for Conducting an Interlaboratory Study to Determine the Precision of a Test Method

<sup>1</sup> This test method is under the jurisdiction of ASTM Committee C08 on Refractories and is the direct responsibility of Subcommittee C08.01 on Strength. Current edition approved Sept. 1, 2014. Published October 2014. Originally approved in 1999. Last previous edition approved in 2009 as C1419 – 99a (2009). DOI: 10.1520/C1419-14.

<sup>2</sup> For referenced ASTM standards, visit the ASTM website, www.astm.org, or contact ASTM Customer Service at service@astm.org. For *Annual Book of ASTM Standards* volume information, refer to the standard's Document Summary page on the ASTM website.

IEEE/ASTM SI10 American National Standard for Use of the International System of Units (SI): The Modern Metric System

## 3. Terminology

3.1 *Definitions of Terms Specific to This Standard:*

3.1.1 *longitudinal sonic pulse, n*—a sonic pulse in which the displacements are in the direction of propagation of the pulse.

3.1.2 *pulse travel time, (T<sub>t</sub>), n*—the total time, measured in microseconds, required for the sonic pulse to traverse the specimen being tested, and for the associated electronic signals to traverse the circuits of the pulse propagation circuitry.

3.1.3 *zero time, (T<sub>o</sub>), n*—the travel time (correction factor), measured in microseconds, associated with the electronic circuits in the pulse-propagation system.

## 4. Summary of Test Method

4.1 The velocity of sound waves passing through the test specimen is determined by measuring the distance through the specimen and dividing by the time lapse between the transmitted pulse and the received pulse.<sup>3,4</sup> An approximate value for Young's modulus can be obtained as follows:

$$E = \rho v^2 \quad (1)$$

where:

$E$  = Young's modulus of elasticity, Pa,

$\rho$  = density, kg/m<sup>3</sup>, and

$v$  = signal velocity, m/s.

4.2 Strictly speaking, the elastic constant given by this measurement is not  $E$  but  $C_{33}$ , provided the sonic pulse is longitudinal and the direction of propagation is along the axis of symmetry.<sup>3,4</sup>

## 5. Significance and Use

5.1 This test method is used to determine the sonic velocity and approximate Young's modulus of refractory shapes at

<sup>3</sup> Schreiber, Anderson, and Soga, *Elastic Constants and Their Measurement*, McGraw-Hill Book Co., 1221 Avenue of the Americas, New York, NY 10020, 1973.

<sup>4</sup> *American Institute of Physics Handbook*, 3rd ed., McGraw-Hill Book Co., 1221 Avenue of the Americas, New York, NY 10020, 1972, pp. 3–98ff.

room temperature. Since this test is nondestructive, specimens may be used for other tests as desired.

5.2 This test method is useful for research and development, engineering application and design, manufacturing quality and process control, and for developing purchasing specifications.

**6. Apparatus**

6.1 *Driving Circuit*, which consists of an ultra sonic pulse generator capable of producing pulses in a frequency range from 0.5 to 2.5 MHz.

6.2 *Transducer*, input.

6.3 *Transducer*, output.

6.4 *Oscilloscope*, dual trace with a preamplifier and time delay circuitry.

6.5 See Fig. 1 for a typical set-up.

**7. Test Specimen**

7.1 Specimens may be prisms of any desired length with parallel smooth surfaces. Opposite surfaces across the length, width, and thickness shall be parallel. The smallest dimension shall be greater than 5 times the diameter of the largest aggregate in the refractory. The surface on which the transduc-

ers will be located must have a width of at least 1.5 times the diameter of the transducer being used.

7.2 Dry the specimens in an oven at 110°C for a minimum of 5 h. Cool to room temperature. Test for sonic velocity within 5 h of drying.

7.3 *Measurement of Density and Dimensions*—Calculate the density of the specimens by Test Methods C134 and determine the specimen lengths by either Test Methods C134 or C179.

**8. Procedure**

8.1 Assemble and connect the apparatus as shown in Fig. 1 and refer to the equipment manufacturer’s instructions for hook up precautions. If using commercially available equipment designed to measure sonic velocity, refer to the manufacturer’s set-up and operating instructions. Allow adequate time for the test apparatus to warm up and stabilize.

8.2 Provide a suitable coupling medium on the transducer faces.

NOTE 1—Petroleum jelly or grease couple well but may be difficult to remove for subsequent tests on the same specimen.

8.3 Bring the transducer faces into intimate contact, but do not exceed the manufacturer’s recommended contact pressure.

8.4 Determine  $T_o$ , the zero time (zero correction) measured in microseconds, associated with the electronic circuits in the pulse propagation instrument and coupling. Alternately, if a commercially available apparatus is used, which utilizes a zero offset and a supplied calibration standard, the instrument can be zeroed using the standard and  $T_o$  does not have to be determined or used in the final calculation.

8.5 Measure and weigh and calculate the density of the test specimen as in 7.3.

8.6 Lightly coat the faces of the test specimen that will be in contact with the transducers with the coupling medium. Position the transducers on opposite surfaces so that they provide a mirror image and that the distance between the input transducer and the output transducer is equal to the dimension through which the measurement is performed. Place the transducers against the test specimen. Apply firm pressure until the pulse travel time stabilizes.

8.7 Determine  $T_t$ , the pulse travel time from the oscilloscope traces as illustrated in Fig. 2, or, if the instrument used has a zero correction,  $T_c$ , the corrected travel time.

**9. Calculation**

9.1 *Velocity of Signal:*

$$v = \frac{L}{T_t - T_o} \tag{2}$$

or

$$v = \frac{L}{T_c} \tag{3}$$

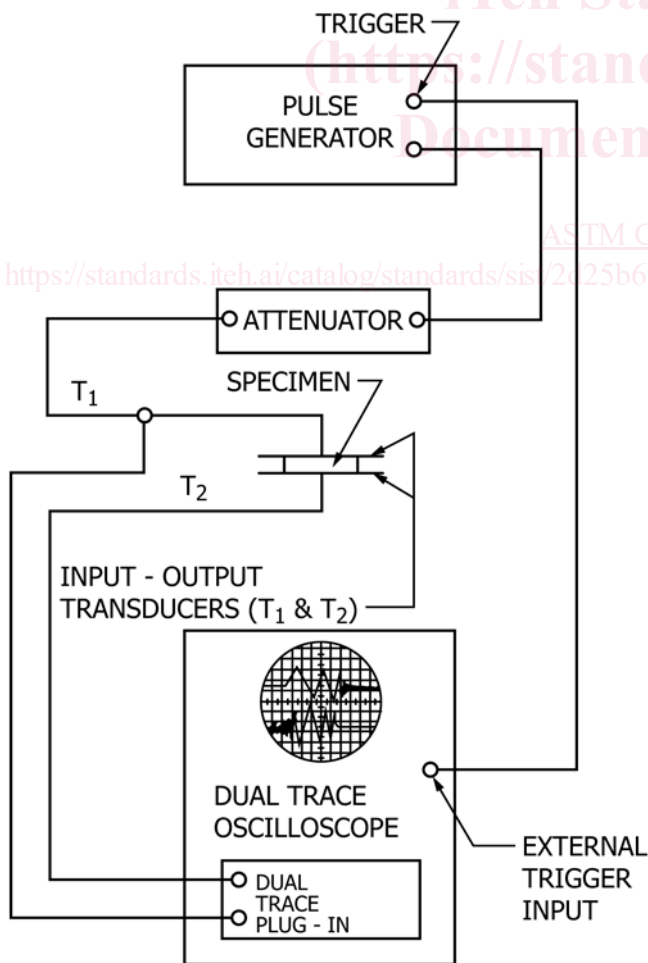

FIG. 1 Equipment Set-up