



# Standard Practice for Selection and Application of Thermal Insulation for Piping and Machinery<sup>1</sup>

This standard is issued under the fixed designation F 683; the number immediately following the designation indicates the year of original adoption or, in the case of revision, the year of last revision. A number in parentheses indicates the year of last reappraisal. A superscript epsilon ( $\epsilon$ ) indicates an editorial change since the last revision or reappraisal.

*This standard has been approved for use by agencies of the Department of Defense.*

## 1. Scope

1.1 This practice provides guidance in the selection of types and thicknesses of thermal insulation materials for piping, machinery, and equipment for nonnuclear shipboard applications. Methods and materials for installation, including lagging, are also detailed.

1.2 Supplemental requirements and exceptions to the requirements discussed herein for ships of the U.S. Navy are included in Supplementary Requirements S1.

1.3 Asbestos or asbestos-containing materials shall not be used.

1.4 The values stated in inch-pound units are to be regarded as the standard. The values given in parentheses are for information only.

1.5 *This standard does not purport to address all of the safety concerns, if any, associated with its use. It is the responsibility of the user of this standard to establish appropriate safety and health practices and determine the applicability of regulatory limitations prior to use.*

## 2. Referenced Documents<sup>2</sup>

### 2.1 ASTM Standards:

- A 167 Specification for Stainless and Heat-Resisting Chromium-Nickel Steel Plate, Sheet, and Strip<sup>3</sup>
- A 653/A 653M Specification for Steel Sheet, Zinc-Coated (Galvanized) or Zinc-Iron Alloy-Coated (Galvannealed) by the Hot Dip Process<sup>4</sup>
- B 209 Specification for Aluminum and Aluminum-Alloy Sheet and Plate<sup>5</sup>
- B 209M Specification for Aluminum and Aluminum-Alloy Sheet and Plate [Metric]<sup>5</sup>

- C 168 Terminology Relating to Thermal Insulating Materials<sup>6</sup>
  - C 195 Specification for Mineral Fiber Thermal Insulating Cement<sup>6</sup>
  - C 449/C449M Specification for Mineral Fiber Hydraulic-Setting Thermal Insulating and Finishing Cement<sup>6</sup>
  - C 533 Specification for Calcium Silicate Block and Pipe Thermal Insulation<sup>6</sup>
  - C 534 Specification for Preformed Flexible Elastomeric Cellular Thermal Insulation in Sheet and Tubular Form<sup>6</sup>
  - C 547 Specification for Mineral Fiber Pipe Insulation<sup>6</sup>
  - C 552 Specification for Cellular Glass Thermal Insulation<sup>6</sup>
  - C 553 Specification for Mineral Fiber Blanket Thermal Insulation for Commercial and Industrial Applications<sup>6</sup>
  - C 610 Specification for Molded Expanded Perlite Block and Pipe Thermal Insulation<sup>6</sup>
  - C 612 Specification for Mineral Fiber Block and Board Thermal Insulation<sup>6</sup>
  - C 680 Practice for Determination of Heat Gain or Loss and the Surface Temperatures of Insulated Pipe and Equipment Systems by the Use of a Computer Program<sup>6</sup>
  - C 892 Specification for High-Temperature Fiber Blanket Thermal Insulation<sup>6</sup>
  - C 1482 Specification for Polyimide Flexible Cellular Thermal and Sound Absorbing Insulation<sup>6</sup>
  - D 962 Specification for Aluminum Powder and Paste Pigments for Paints<sup>7</sup>
  - D 3400 Specification for Liquid Sodium Silicates<sup>8</sup>
  - F 1138 Specification for Spray Shields for Mechanical Joints<sup>9</sup>
- ### 2.2 Federal Specifications:<sup>10</sup>
- HH-P-31 Packing and Lagging Material, Fibrous Glass Metallic and Plain Cloth and Tape
  - TT-P-28 Paint, Aluminum, Heat Resisting (1200°F)
- ### 2.3 Military Specifications:<sup>10</sup>
- DoD-C-15328 Primer (Wash), Pretreatment (Formula No.

<sup>1</sup> This practice is under the jurisdiction of ASTM Committee F25 on Ships and Marine Technology and is the direct responsibility of Subcommittee F25.02 on Insulation/Processes.

Current edition approved Feb. 10, 2002. Published April 2002. Originally published as F 683 – 80. Last previous edition F 683 – 00.

<sup>2</sup> The latest revision of all referenced documents shall apply.

<sup>3</sup> *Annual Book of ASTM Standards*, Vol 01.03.

<sup>4</sup> *Annual Book of ASTM Standards*, Vol 01.06.

<sup>5</sup> *Annual Book of ASTM Standards*, Vol 02.02.

<sup>6</sup> *Annual Book of ASTM Standards*, Vol 04.06.

<sup>7</sup> *Annual Book of ASTM Standards*, Vol 06.03.

<sup>8</sup> Discontinued; see 2001 *Annual Book of ASTM Standards*, Vol 15.04.

<sup>9</sup> *Annual Book of ASTM Standards*, Vol 01.07.

<sup>10</sup> Available from Standardization Documents Order Desk, Bldg. 4 Section D, 700 Robbins Ave., Philadelphia, PA 19111-5094, Attn: NPODS.



- 117 for Metals) Metric
- DoD-C-24596 Coating Compounds, Nonflaming, Fire-Protective (Metric)
- DoD-E-24607 Enamel, Interior, Nonflaming (Dry), Chlorinated Alkyd Resin, Semigloss (Metric)
- DoD-I-24688 Type I, Insulation, Polyimide, Sheet and Tube
- MIL-A-3316 Adhesive, Fire-Resistant, Thermal Insulation
- MIL-A-24179 Adhesive, Flexible, Unicellular-Plastic, Thermal Insulation
- MIL-C-2861 Cement Insulation, High Temperature
- MIL-C-19565 Coating Compounds, Thermal Insulation Pipe Covering—Fire and Water-Resistant Vapor Barrier and Weather Resistant
- MIL-C-20079 Cloth, Glass, Tape, Textile Glass and Thread, Glass
- MIL-C-22395 Compound, End Sealing, Thermal Insulation Pipe Covering—Fire, Water, and Weather Resistant
- MIL-I-22023 Insulation Felt, Thermal and Sound Absorbing Felt, Fibrous Glass, Flexible
- MIL-I-2781 Insulation, Pipe, Thermal
- MIL-I-2818 Insulation Blanket, Thermal, Fibrous Material
- MIL-I-2819 Insulation, Block, Thermal
- MIL-I-16411 Insulation, Felt, Thermal, Glass Fiber
- MIL-I-22344 Insulation, Pipe, Thermal, Fibrous Glass
- MIL-P-15280 Plastic Material, Unicellular (Sheets and Tubes)
- MIL-STD-769 Thermal Insulation Requirements for Machinery and Piping
- MIL-STD-2118 Trap, Steam, Angle, Thermostatic
- 2.4 *Other Documents:*
- Title 46 Code of Federal Regulations (CFR), Shipping (Parts 164.009 and 164.012)<sup>10</sup>
- Electric Boat Specification 4013 Anti-Sweat and Refrigerant Insulation (Sheet and Tubes)<sup>11</sup>
- 2.5 *Drawings, NAVSHIP:*
- 804-5959214 Piping Insulation, Installation Details<sup>12</sup>
- 804-5959212 Machinery Insulation, Installation Details<sup>12</sup>
- 2.6 *NAVSEA:*
- Naval Ships Technical Manual, Chapter 635—Thermal, Fire, and Acoustic Insulation<sup>10</sup>
- 803-5184182 Passive Fire Protection Insulation<sup>10</sup>

### 3. Terminology

3.1 *Definitions*—For definitions of terms relating to insulating materials used in this practice, refer to Terminology C 168.

### 4. Materials and Manufacture

4.1 *Insulation and Lagging Material Specifications*, as listed in Tables 1-17, describe those materials that are intended for use in the indicated temperature ranges. The specifications and requirements outlined herein are not intended to prevent the use of new test methods or materials, provided that sufficient technical data is submitted to demonstrate that the

proposed test method or material is equivalent in quality, effectiveness, durability, and safety to that prescribed by this practice.

### 5. General Requirements

5.1 Piping, including valves, fittings, and flanges conveying vapors, gases, or liquids that attain temperatures outside the range from 55 to 125°F (13 to 52°C) during normal operation, shall be insulated except as otherwise stated herein.

5.2 The insulation thicknesses specified in this practice are designed to maintain the surface temperature at or below 125°F (52°C) for fluid temperatures up to 650°F (343°C) with an ambient temperature of 85°F (29°C). For fluid temperatures above 650°F, the surface will be maintained at a maximum of 133°F (56°C).

5.2.1 Insulation thicknesses have been calculated in accordance with the computer programs in Practice C 680.

5.3 Piping and units of equipment with designated internal temperatures of 300°F (149°C) and over shall be insulated from their supports or the supports insulated from the structures to which they are attached where the heat transmitted may be objectionable on the opposite side of the structure.

5.4 Insulated piping passing through accommodation, service, and control spaces must be covered with approved incombustible materials which meet 46 CFR, Sections 164.009 and 164.012. Elastomeric foam plastic insulation shall not be used in these spaces.

5.5 Special consideration shall be given to the insulation of integral piping supplied with and mounted on equipment or machinery. In these cases, alternative materials and methods of installation may be considered provided that they comply with the performance requirements of this practice.

5.6 Minimum insulation requirements have not been established for those surfaces or applications in which insulations had not been specified in past practices. In effect, the following surfaces are excluded from insulation requirements:

5.6.1 Surfaces where application of insulation would affect proper operation.

5.6.2 Equipment, components, and systems designed for the dispersion of heat.

5.6.3 Thermostatic steam traps and 24 in. (620 mm) of piping upstream of traps, which shall not be insulated. When located in areas in which personnel protection is required, expanded metal shields or multilayer glass cloth shall be provided.

5.6.4 Mechanical joints exposed to subatmospheric pressures and those included in the fuel oil service piping from heaters to burners.

5.6.5 Fuel oil piping between headers and burners.

5.6.6 Piping above 125°F (52°C) in bilges, not within watertight enclosures.

5.6.7 Piping in locations in which sweating and possible resultant rust is not objectionable such as voids, bilges, and shaft alleys, plus plumbing fixtures and associated supply and drain piping immediately adjacent thereto.

5.6.8 Deadend hot water piping  $\frac{3}{8}$  in. (10 mm) and smaller.

5.6.9 Pressure-gage piping.

5.6.10 Soot-blower valve units and soot-blower flanges.

<sup>11</sup> Available from Electric Boat Corp., 75 Eastern Point Rd., Groton, CT 06340.

<sup>12</sup> Available from U.S. Government Printing Office.



**TABLE 1 Insulation and Lagging Materials for Pipe, Tubing, and Fittings Used for Interior Piping Systems<sup>A,B</sup>**

Temperature Range °F (°C)	Insulation	Specification	Lagging <sup>C</sup>	Specification
-20 to +40 (-29 to +4)	cellular glass	C 552, Type II	fibrous glass cloth	MIL-C-20079, Type I, Classes 3 through 9 commercial
	polyimide foam <sup>D</sup>	C 1482, Type I, with vapor retarder	sheet steel galvanized fibrous glass cloth	MIL-C-20079, Type I, Classes 3 through 9
	elastomeric foam plastic <sup>A</sup>	MIL-P-15280, Form T	fibrous glass cloth	MIL-C-20079, Type I, Classes 3 through 9
41 to 125 (5 to 51)	cellular glass	C 552, Type II	fibrous glass cloth	MIL-C-20079, Type I, Classes 3 through 9 commercial
	polyimide foam	C 1482, Type I, with vapor retarder	sheet steel galvanized fibrous glass cloth	MIL-C-20079, Type I, Classes 3 through 9
	elastomeric foam plastic <sup>A</sup>	MIL-P-15280, Form T	fibrous glass cloth	MIL-C-20079, Type I, Classes 3 through 9
	mineral fiber <sup>D</sup>	C 547, Type II	fibrous glass cloth	MIL-C-20079, Type I, Classes 3 through 9 commercial
126 to 450 (52 to 232)	cellular glass	C 552, Type II	sheet steel galvanized fibrous glass cloth	MIL-C-20079, Type I, Classes 3 through 9 commercial
	polyimide foam <sup>E</sup> 400°F (204°C) max	C 1482, Type I	fibrous glass cloth	MIL-C-20079, Type I, Classes 3 through 9
	elastomeric foam plastic <sup>A</sup> 180°F (82°C) max	MIL-P-15280, Form T	fibrous glass cloth	MIL-C-20079, Type I, Classes 3 through 9 commercial
	calcium silicate	C 533	sheet steel galvanized fibrous glass cloth	MIL-C-20079, Type I, Classes 3 through 9 commercial
	expanded perlite	C 610	sheet steel galvanized fibrous glass cloth	MIL-C-20079, Type I, Classes 3 through 9 commercial
451 to 1050 (233 to 566)	cellular glass, 800°F (427°C) max	C 552, Type II	sheet steel galvanized fibrous glass cloth	MIL-C-20079, Type I, Classes 3 through 9 commercial
	mineral fiber	C 547, Class 2 (850°F [454°C] max) or Class 3	sheet steel galvanized sheet steel black	commercial
	calcium silicate	C 533	sheet steel black	commercial
	expanded perlite	C 610	sheet steel black	commercial

<sup>A</sup>See 5.4.

<sup>B</sup>Insulation and lagging materials are acceptable for the temperature ranges indicated; other materials may be used provided the requirements of this practice are satisfied. Thermal insulating tape may be used as allowed by Section 8 of this practice.

<sup>C</sup>Lagging is to be used over insulation only.

<sup>D</sup>See Supplementary Requirements S1.5.

<sup>E</sup>See Supplementary Requirements S1.15.

5.6.11 Piping in voids and cofferdams except where omitting insulation may be detrimental to system operation, such as catapult steam.

5.6.12 Safety valve bodies, springs, and lifting gear.

5.6.13 Piping over shower stalls and behind and under lavatories.

5.6.14 Valves or flanges in the collection holding tank (CHT) system.

5.7 Higher-temperature-type insulations may be used where lower-temperature-type insulations are specified, provided that they are satisfactory in all other respects.

5.8 In “high traffic” locations in which the completed insulation and lagging is liable to abuse, such as shipping, unshipping, and maintenance areas, protective sheet metal lagging should be installed. Where metal lagging is required, any of the materials listed in Table 13 are acceptable, except for boiler uptake applications in which metal lagging shall be galvanized sheet steel, in accordance with Specification A 653/A 653M, with Coating Designation G-115, and not less than 1/32 in. (0.8 mm) thick.

5.9 Before installing insulation, surface preparation of the piping is to be accomplished in accordance with the ship’s painting schedule.

5.10 Lacing hooks should be welded to the structure or equipment (with permission of the vendor of the equipment) for securing insulation to the equipment.

5.11 For bends, fittings, and so forth, where molded sections of pipe insulation cannot be used, mitered sections of the pipe insulation or premolded fittings and covers may be used, provided that they are suitable for the temperature and that the requirements of this practice are satisfied (see 4.1 and 5.4). Fittings in sizes under 2-in. (51-mm) nominal pipe size (NPS) may be insulated with insulating cement, in accordance with Specification C 449/C 449M.

5.12 Where insulation specifications listed in Tables 1 and 3 provide for the use of nonmetal “jacketed”-type insulation, separate lagging material may be omitted.

5.13 Single-layered insulation construction shall be permitted on all surfaces operating at temperatures below 600°F (316°C). Double-layered insulation construction shall be used with all joints staggered on all surfaces operating at temperatures of 600°F and above, except single-layered construction will be permitted when the total insulation thickness is 3 in. (75 mm) or less or the pipe size is NPS 2 in. (50 mm) or below.



**TABLE 2 Insulation and Lagging Materials for Pipe, Tubing, and Fittings Used for Weather-Exposed Piping Systems<sup>A</sup>**

Temperature Range ° F (°C)	Insulation	Specification	Lagging <sup>B</sup>	Specification
-20 to +40 (-29 to +4)	cellular glass	C 552, Type II	fibrous glass cloth	MIL-C-20079, Type I Class 7 (fittings) Class 9 (piping)
	polyimide foam	C 1482, Type I, with vapor retarder	fibrous glass cloth	MIL-C-20079, Type I Class 7 (fittings) Class 9 (piping)
	perlite	C 610	fibrous glass cloth	MIL-C-20079, Type I Class 7 (fittings) Class 9 (piping)
41 to 100 (5 to 37)	cellular glass	C 552, Type II	corrosion-resistant steel	A 167, Type 304
	polyimide foam	C 1482, Type I, with vapor retarder	fibrous glass cloth	MIL-C-20079, Type I Class 7 (fittings) Class 9 (piping)
	perlite	C 610	corrosion-resistant steel	A 167, Type 304
	calcium silicate	C 533	corrosion-resistant steel	A 167, Type 304
	mineral fiber <sup>C</sup>	C 547, Class 2 or 3	corrosion-resistant steel	A 167, Type 304
101 to 450 (38 to 232)	cellular glass	C 552, Type II	corrosion-resistant steel	A 167, Type 304
	polyimide foam <sup>B</sup> 400°F (204°C) max	C 1482, Type I	corrosion-resistant steel	A 167, Type 304
	perlite	C 610	corrosion-resistant steel	A 167, Type 304
	calcium silicate	C 533	corrosion-resistant steel	A 167, Type 304
	mineral fiber <sup>C</sup>	C 547, Class 2 or 3	corrosion-resistant steel	A 167, Type 304

<sup>A</sup>Insulation and lagging materials listed are acceptable for the temperature ranges indicated; other materials may be used provided the requirements of this practice are satisfied.

<sup>B</sup>See Supplementary Requirements S1.15.

<sup>C</sup>See Supplementary Requirements S1.5.

## 6. Selection Requirements, Piping

6.1 *Interior Piping, Temperature Range from -20 to +40°F (-29 to +4°C)*—Use for air conditioning and ship's stores refrigerant piping and other services within the temperature range.

6.1.1 For insulation and lagging materials, see Table 1.

6.1.2 For insulation thickness, see Table 4 or Table 5.

6.1.3 For installation details, see Fig. 1, Fig. 2, or Fig. 3 as applicable.

6.2 *Interior Piping, Temperature Range from 41 to 125°F (5 to 52°C)*—Use for cold freshwater, plumbing drains, firemain, main and auxiliary, saltwater circulating, and saltwater cooling, piping, and other services within the temperature range.

6.2.1 For insulation and lagging materials, see Table 1.

6.2.2 For insulation thickness, see Table 2, Table 3, or Table 4.

6.2.3 For installation details, see Fig. 1, Fig. 2, or Fig. 3 as applicable.

6.2.4 *Special Conditions:*

6.2.4.1 Piping systems operating in this temperature range including water closet drain piping do not require insulation except where damage or discomfort may result from condensation.

6.2.4.2 Dry firemain need only be insulated above ceilings and in areas in which damage or discomfort may be realized from condensation.

6.2.4.3 If cold, fresh, or potable water tanks (not having a side integral with the shell) are installed in a heated area, the piping to the pumps and therefore to the services need not be insulated. If this water is being used for flushing water closets, the drain piping need not be insulated.

6.2.4.4 Freshwater fill piping inside the ship shall be insulated.

6.2.4.5 Drains from drinking water chillers shall be insulated.

6.3 *Interior Piping, Temperature Range from 126 to 450°F (52 to 232°C)*—Use for hot freshwater, hot-water heating, fuel oil service discharge from heaters to headers, condensate, and air ejector piping, boiler feed, high- and low-pressure steam drain piping, and other services within the temperature range.

6.3.1 For insulation and lagging materials, see Table 1.

6.3.2 For insulation thickness, see Table 4, Table 5, Table 7, Table 8, or Table 9.

6.3.3 For installation details, see Fig. 1, Fig. 2, Fig. 3, Fig. 4, Fig. 5, or Fig. 6, as applicable.

6.3.4 *Special Conditions*—On piping, tubing, and fittings sized less than NPS 3/8 in., insulation need be applied only where required for personnel protection.

6.4 *Interior Piping, Temperature Range from 451 to 1200°F (233 to 649°C)*—Use for main steam, auxiliary steam, exhaust and bleed steam, gland seal steam and exhaust, high- and low-pressure steam drains, soot blower steam, boiler blow,



**TABLE 3 Insulation and Lagging Materials for Machinery and Equipment<sup>A,B</sup>**

Temperature Range °F (°C)	Insulation	Specification	Lagging	Specification
-20 to +40 (-29 to +4)	elastomeric foam plastic <sup>A</sup>	MIL-P-15280, Form S	fibrous glass cloth	MIL-C-20079, Type I, Classes 3 through 9
	polyimide foam	C 1482, Type I	fibrous glass cloth with vapor retarder	MIL-C-20079 Type I, Classes 3 through 9
	cellular glass	C 552, Type II	sheet steel galvanized	commercial <sup>C</sup>
41 to 125 (5 to 51)	elastomeric foam plastic <sup>A</sup>	MIL-P-15280, Form S	fibrous glass cloth	MIL-C-20079, Type I, Classes 3 through 9
	polyimide foam	C 1482, Type I	fibrous glass cloth with vapor retarder	MIL-C-20079, Type I, Classes 3 through 9
	cellular glass	C 552, Type I	fibrous glass cloth, or sheet steel black commercial	MIL-C-20079, Type I, Classes 3 through 9 commercial <sup>C</sup>
	mineral fiber blanket	C 553	sheet steel black, commercial or fibrous glass cloth with vapor retarder	MIL-C-20079, Type I, Classes 3 through 9 commercial <sup>C</sup>
126 to 1200 (52 to 649)	fibrous glass felt	MIL-I-16411, Type II	fibrous glass cloth glass wire, reinforced	MIL-C-20079, Type I, Classes 7 or 9 HH-P-31, Type I
	polyimide foam <sup>D</sup> 400°F (204°C) max	C 1482, Type I	fibrous glass cloth	MIL-C-20079, Type I, Classes 3 through 8
	refractory fiber blanket	C 892, Grade 6 or 8	sheet steel black commercial or fibrous glass cloth glass wire, reinforced	MIL-C-20079, Type I, Classes 3 through 9 HH-P-31, Type I
	elastomeric foam plastic (180°F [82°C] max)	MIL-P-15280 sheet	fibrous glass cloth	MIL-C-20079, Type I, Classes 3 through 9
	high-temperature insulating cement <sup>E</sup>	C 195		
	calcium silicate insulating block	C 553		
	mineral fiber blanket (1000°F [538°C] max)	C 553, C 612	sheet steel black, or fibrous glass cloth glass wire, reinforced	MIL-C-20079, Type I, Classes 3 through 9 HH-P-31, Type I
	perlite	C 610	fibrous glass cloth	MIL-C-20079, Type I, Classes 3 through 9

<sup>A</sup>See 5.4.

<sup>B</sup>Insulation and lagging materials are acceptable for the temperature ranges indicated; other materials may be used provided the requirements of this practice are satisfied.

<sup>C</sup>With or without rewettable adhesive.

<sup>D</sup>See Supplementary Requirements S1.15.

<sup>E</sup>When insulating cement is used, it shall be applied in successive layers, ½ to 1 in. (13 to 25 mm) in thickness, until the total thickness specified in Table 7 has been reached. Galvanized iron wire netting, 1-in. (13-mm) mesh, shall be installed between layers. A ½-in. (13-mm) thickness of finishing cement, in accordance with Specification C 449/C 449M, shall be applied over the last layer of insulating cement.

safety and relief valve escape steam heating, diesel exhaust piping, and other services within the temperature range.

6.4.1 For insulation and lagging materials, see Table 1.

6.4.2 For insulation thickness, see Table 4, Table 7, Table 8, or Table 9, as applicable.

6.4.3 For installation details, see Fig. 1, Fig. 4, Fig. 5, or Fig. 6, as applicable.

6.4.4 *Special Conditions:*

6.4.4.1 The soot blower piping between the root valve and the soot blower heads shall have an insulation thickness of one half of that indicated for a continually operating system at the same temperature.

6.4.4.2 Main steam piping insulation shall be arranged with

removable pads to bare sections for audio gaging when required.

6.4.4.3 Turbogenerator exhaust to main and auxiliary condensers do not require insulation except in areas susceptible to personnel contact.

6.4.4.4 Safety and relief valve escape piping need not be insulated except in areas susceptible to contact by personnel.

6.4.4.5 Boiler blow piping need not be insulated except in areas susceptible to contact by personnel.

6.4.4.6 On piping, tubing, and fittings sizes less than NPS ¾ in. (10 mm), insulation need be applied only where required for personnel protection.

6.4.4.7 Steam smothering and steam to the sea chests need



**TABLE 4 Thickness of Cellular Glass Insulation for Piping, -20 to 800°F (-29 to 427°C)<sup>A</sup>**

Nominal Pipe Size, in. (mm)	Maximum Temperature, °F (°C) × Thickness, in. (mm)								
	-20 to 40 <sup>B</sup> (-29 to 4)	41 to 125 <sup>C</sup> (5 to 52)	250 (121)	350 (177)	450 (232)	550 (288)	650 (343)	750 (399)	850 (454)
¼ (6) and above	2½ (63) 1½ <sup>D</sup> (38)	1 (25) ½ <sup>D</sup> (13)	...	...	...	...	...	...	...
1½ (38) and below	...	...	1 (25)	1 (25)	1½ (38)	2 (51)	2½ (63)	2½ (63)	3 (76)
2 (51)	...	...	1 (25)	2 (51)	1½ (38)	2 (51)	3 (76)	3 (76)	3½ (89)
2½, 3 (63, 76)	...	...	1 (25)	1½ (38)	2 (51)	2½ (63)	3 (76)	3½ (89)	4 (102)
4 (102)	...	...	1 (25)	1½ (38)	2 (51)	2½ (63)	3½ (89)	3½ (89)	4 (102)
5, 6 (127, 152)	...	...	1 (25)	1½ (38)	2 (51)	3 (76)	3½ (89)	3½ (89)	4½ (114)
8 (203)	...	...	1½ (38)	1½ (38)	2 (51)	3 (76)	3½ (89)	4 (102)	5 (127)
10 (254)	...	...	1½ (38)	1½ (38)	2 (51)	3 (76)	4 (102)	4 (102)	5 (127)
12 (305)	...	...	1½ (38)	1½ (38)	2½ (63)	3 (76)	4 (102)	4½ (114)	5½ (140)
14 (356)	...	...	1½ (38)	1½ (38)	2½ (63)	3½ (89)	4 (102)	4½ (114)	5½ (140)
16 (406)	...	...	1½ (38)	1½ (38)	2½ (63)	3½ (89)	4½ (114)	4½ (114)	5½ (140)
18 (457)	...	...	1½ (38)	1½ (38)	2½ (63)	3½ (89)	4½ (114)	4½ (114)	5½ (140)

<sup>A</sup>Thickness of cellular glass, in accordance with Specification C 552, Type II.

<sup>B</sup>For refrigerant piping.

<sup>C</sup>For antisweat applications.

<sup>D</sup>Thickness for applications in air-conditioned spaces only.

**TABLE 5 Thickness of Elastomeric Foam Plastic Insulation Piping, -20 to 180°F (-29 to 82°C)<sup>A</sup>**

Nominal Size, in. (mm)	Temperature Range, °F (°C)	Nominal Thickness, in. (mm)	
¼ (6) and above	-20 to 40 (-29 to 4) <sup>B</sup>	1½ (38)	1 (25) <sup>C</sup>
	41 to 125 (5 to 52) <sup>D</sup>	¾ (19)	½ (13) <sup>C</sup>
	126 to 180 (53 to 82)	½ (13)	½ (13) <sup>C</sup>

<sup>A</sup>Thickness of elastomeric foam plastic insulation, conforming with MIL-P-15280, Form T.

<sup>B</sup>For refrigerant piping.

<sup>C</sup>For antisweat applications.

<sup>D</sup>Thickness for applications in air-conditioned spaces only.

**TABLE 6 Thickness of Polyimide Foam Insulation Piping, -20 to 400°F (-29 to 204°C)<sup>A</sup>**

Nominal Size, in. (mm)	Temperature Range, °F (°C)	Nominal Thickness, in. (mm)	
¼ (6) and above	-20 to 40 (-29 to 4) <sup>B</sup>	1½ (38)	1 (25) <sup>C</sup>
	41 to 125 (5 to 52) <sup>D</sup>	¾ (19)	½ (13) <sup>C</sup>
	126 to 180 (53 to 82)	½ (13)	
	181 to 250 (83 to 121)	¾ (19)	
	251 to 350 (122 to 177)	1 (25)	
	351 to 400 (178 to 204)	1½ (38)	

<sup>A</sup>Thickness of polyimide foam insulation conforming with Specification C 1482.

<sup>B</sup>For refrigerant piping.

<sup>C</sup>For antisweat applications.

<sup>D</sup>Thickness for applications in air conditioned spaces only.

be insulated only in those areas susceptible to personnel contact.

6.5 *Weather-Exposed Piping, Temperature Range from -20 to +40°F (-29 to +4°C)*—Use for low-temperature piping exposed to the weather.

6.5.1 For insulation and lagging materials, see Table 2.

6.5.2 For insulation thickness, see Table 4.

6.5.3 For installation details, see Fig. 3, Fig. 7, or Fig. 8.

6.5.4 *Special Conditions:*

6.5.4.1 Piping exposed to the weather should also be effectively insulated against freezing. The thickness of insulation required to prevent freezing is determined by calculation based on the system fluid, system velocity, type of insulation to be used, and climatic conditions involved. This does not apply to systems that are normally secured and drained.

**TABLE 7 Thickness of Mineral Fiber Insulation for Hot Piping, 850°F (454°C) Maximum<sup>A,B</sup>**

Nominal Pipe Size, in. (mm)	Maximum Temperature, °F (°C) × Thickness, in. (mm)							
	150 (66)	250 (121)	350 (177)	450 (232)	550 (288)	650 (343)	750 (399)	850 (454)
1½ (38) and below	1 (25)	1 (25)	1 (25)	1½ (38)	2 (51)	2 (51)	2½ (63)	3 (76)
2 (51)	1 (25)	1 (25)	1 (25)	1½ (38)	2 (51)	2½ (63)	3 (76)	3½ (89)
2½, 3 (63, 76)	1 (25)	1 (25)	1 (25)	1½ (38)	2 (51)	3 (76)	3½ (89)	3½ (89)
4 (102)	1 (25)	1 (25)	1 (25)	1½ (38)	2 (51)	3 (76)	3½ (89)	4 (102)
5, 6 (127, 152)	1 (25)	1 (25)	1 (25)	2 (51)	2½ (63)	3 (76)	3½ (89)	4 (102)
8 (203)	1 (25)	1 (25)	1 (25)	2 (51)	2½ (63)	3 (76)	3½ (89)	4½ (114)
10 (254)	1 (25)	1 (25)	1½ (38)	2 (51)	2½ (63)	3½ (89)	3½ (89)	4½ (114)
12 (305)	1 (25)	1 (25)	1½ (38)	2 (51)	2½ (63)	3½ (89)	4½ (114)	4½ (114)
14, 16, 18 (356, 406, 457)	1 (25)	1 (25)	1½ (38)	2 (51)	3 (76)	3½ (89)	4½ (114)	5 (127)

<sup>A</sup>Commercially known as fibrous glass.

<sup>B</sup>Thickness of mineral fiber insulation in accordance with Specification C 547, Class 2.

6.5.4.2 At pipe supports, remove only enough insulation to provide a snug fit. Fill voids between insulation and support with tightly packed fibrous glass felt, conforming with MIL-I-16411, Type II, to within ¼ in. (6 mm) of the insulation surface. Fill the remainder with end-sealing compound, conforming with MIL-C-22395, overlapping both the support member and the adjacent insulation. Lag and coat with the same materials as the adjacent pipe.

6.6 *Weather-Exposed Piping, Temperature Range from 41 to 450°F (5 to 232°C)*—Use for hot piping systems exposed to weather.

6.6.1 For insulation and lagging materials, see Table 2.

6.6.2 For insulation thickness, see Table 4, Table 7, Table 8, or Table 9.

6.6.3 For installation details, see Fig. 3, Fig. 7, or Fig. 8.

6.6.4 *Special Conditions:*

6.6.4.1 Piping exposed to the weather should be effectively insulated against freezing. The thickness of insulation required



**TABLE 8 Thickness of Mineral Fiber Insulation for Hot Piping, 1050°F (566°C) Maximum<sup>A,B</sup>**

Nominal Pipe Size, in. (mm)	Maximum Temperature, °F (°C) × Thickness, in. (mm)									
	150 (66)	250 (121)	350 (177)	450 (232)	550 (288)	650 (343)	750 (399)	850 (454)	950 (510)	1050 (566)
1½ (38) and below	1 (25)	1 (25)	1 (25)	1½ (38)	2 (51)	2 (51)	2 (51)	2½ (63)	3 (76)	3½ (89)
2 (51)	1 (25)	1 (25)	1 (25)	1½ (38)	2 (51)	2 (51)	2½ (63)	3 (76)	3½ (89)	4 (102)
2½, 3 (63, 76)	1 (25)	1 (25)	1 (25)	1½ (38)	2 (51)	2½ (63)	3½ (89)	3½ (89)	4 (102)	4½ (114)
4 (102)	1 (25)	1 (25)	1 (25)	1½ (38)	2 (51)	2½ (63)	3 (76)	3½ (89)	4 (102)	4½ (114)
5, 6 (127, 152)	1 (25)	1 (25)	1½ (38)	2 (51)	2½ (63)	3 (76)	3 (76)	3½ (89)	4½ (114)	5½ (140)
8 (203)	1 (25)	1 (25)	1½ (38)	2 (51)	2½ (63)	3 (76)	3 (76)	4 (102)	4½ (114)	5½ (140)
10 (254)	1 (25)	1 (25)	1½ (38)	2 (51)	2½ (63)	3 (76)	3½ (89)	4 (102)	5 (127)	6 (152)
12 (305)	1 (25)	1 (25)	1½ (38)	2 (51)	2½ (63)	3½ (89)	3½ (89)	4 (102)	5 (127)	6 (152)
14 (356)	1 (25)	1 (25)	1½ (38)	2 (51)	2½ (63)	3½ (89)	3½ (89)	4½ (114)	5½ (140)	6½ (165)
16 (406)	1 (25)	1 (25)	1½ (38)	2 (51)	3 (76)	3½ (89)	3½ (89)	4½ (114)	5½ (140)	6½ (165)
18 (457)	1 (25)	1 (25)	1½ (38)	2 (51)	3 (76)	3½ (89)	4 (102)	4½ (114)	5½ (140)	6½ (165)

<sup>A</sup>Commercially known as mineral wool.

<sup>B</sup>Thickness of mineral fiber insulation, in accordance with Specification C 547, Class 3.

**TABLE 9 Thickness of Calcium Silicate Insulation (Specification C 533) for Hot Piping, 1050°F (566°C) Maximum<sup>A</sup>**

Nominal Pipe Size, in. (mm)	Maximum Temperature, °F (°C) × Thickness, in. (mm)									
	150 (66)	250 (121)	350 (177)	450 (232)	550 (288)	650 (343)	750 (399)	850 (454)	950 (510)	1050 (566)
1½ (38) and below	1 (25)	1 (25)	1 (25)	1½ (38)	2 (51)	2½ (63)	2½ (63)	2½ (63)	3 (76)	3½ (89)
2 (51)	1 (25)	1 (25)	1 (25)	1½ (38)	2 (51)	2½ (63)	2½ (63)	3 (76)	3½ (89)	4 (102)
2½, 3, 4 (63, 76, 102)	1 (25)	1 (25)	1½ (38)	2 (51)	2½ (63)	3 (76)	3 (76)	3½ (89)	4 (102)	5 (127)
5, 6 (127, 152)	1½ (38)	1½ (38)	1½ (38)	2 (51)	2½ (63)	3½ (89)	3½ (89)	4 (102)	4½ (114)	5½ (140)
8 (203)	1½ (38)	1½ (38)	1½ (38)	2 (51)	2½ (63)	3½ (89)	3½ (89)	4 (102)	5 (127)	5½ (140)
10 (254)	1½ (38)	1½ (38)	1½ (38)	2 (51)	3 (76)	3½ (89)	3½ (89)	4½ (114)	5 (127)	6 (152)
12 (305)	1½ (38)	1½ (38)	1½ (38)	2 (51)	3 (76)	3½ (89)	3½ (89)	4½ (114)	5½ (140)	6 (152)
14 (356)	1½ (38)	1½ (38)	1½ (38)	2½ (63)	3 (76)	4 (102)	4 (102)	4½ (114)	5½ (140)	6½ (165)
16, 18 (406, 457)	1½ (38)	1½ (38)	1½ (38)	2½ (63)	3 (76)	4 (102)	4 (102)	5 (127)	5½ (140)	6½ (165)

<sup>A</sup>Thickness of calcium silicate insulation, in accordance with Specification C 533.

**TABLE 10 Thickness of Perlite Insulation (Specification C 610) for Hot Piping, 1050°F (566°C) Maximum<sup>A</sup>**

Nominal Pipe Size, in. (mm)	Maximum Temperature, °F (°C) × Thickness, in. (mm)									
	150 (66)	250 (121)	350 (177)	450 (232)	550 (288)	650 (343)	750 (399)	850 (454)	950 (510)	1050 (566)
1½ (38) and below	1 (25)	1 (25)	1 (25)	1½ (38)	2 (51)	2½ (63)	2½ (63)	2½ (63)	3 (76)	3½ (89)
2 (51)	1 (25)	1 (25)	1 (25)	1½ (38)	2 (51)	2½ (63)	2½ (63)	3 (76)	3½ (89)	4 (102)
2½, 3, 4 (63, 76, 102)	1 (25)	1 (25)	1½ (38)	2 (51)	2½ (63)	3 (76)	3 (76)	3½ (89)	4 (102)	5 (127)
5, 6 (127, 152)	1½ (38)	1½ (38)	1½ (38)	2 (51)	2½ (63)	3½ (89)	3½ (89)	4 (102)	4½ (114)	5½ (140)
8 (203)	1½ (38)	1½ (38)	1½ (38)	2 (51)	2½ (63)	3½ (89)	3½ (89)	4 (102)	5 (127)	5½ (140)
10 (255)	1½ (38)	1½ (38)	1½ (38)	2 (51)	3 (76)	3½ (89)	3½ (89)	4½ (114)	5 (127)	6 (152)
12 (305)	1½ (38)	1½ (38)	1½ (38)	2 (51)	3 (76)	3½ (89)	3½ (89)	4½ (114)	5½ (140)	6 (152)
14 (356)	1½ (38)	1½ (38)	1½ (38)	2½ (63)	3 (76)	4 (102)	4 (102)	4½ (114)	5½ (140)	6½ (163)
16, 18 (406, 457)	1½ (38)	1½ (38)	1½ (38)	2½ (63)	3 (76)	4 (102)	4 (102)	5 (127)	5½ (140)	6½ (165)

<sup>A</sup>Thickness of perlite insulation, in accordance with Specification C 610.

to prevent freezing is determined by calculation based on the system fluid, system velocity, type of insulation to be used, and climatic conditions involved. This does not apply to systems that are normally secured and drained.

6.6.4.2 At pipe supports, remove only enough insulation to provide a snug fit. Fill voids between the insulation and support with tightly packed fibrous glass felt, conforming with MIL-I-16411, Type II, to within ¼ in. (6 mm) of the insulation surface. Fill the remainder with end-sealing compound, conforming with MIL-C-22395, overlapping both the support member and the adjacent insulation. Lag and coat with the same materials as the adjacent pipe.

## 7. Selection Requirements, Machinery and Equipment

7.1 *Temperature Range from -20 to +40°F (-29 to +4°C)*—Use for refrigerant and other equipment within the temperature range.

7.1.1 For insulation and lagging materials, see Table 3.

7.1.2 For insulation thickness, see Table 11.

**TABLE 11 Thickness of Antisweat Insulation for Machinery and Equipment**

Temperature Range, °F (°C)	Material Specification	Nominal Thickness, in. (mm) <sup>A</sup>	
		Unconditional Spaces	Conditioned Spaces
-20 to +40 (-29 to +4)	elastomeric foam plastic, C 534, Type II	2 (51)	1 (25) <sup>B</sup>
	polyimide foam, C 1482, Type I with vapor retarder	2 (51)	1 (25) <sup>B</sup>
	cellular glass, C 552 Type I	3 (76)	1½ (38) <sup>B</sup>
	elastomeric foam plastic, C 534, Type II	¾ (19)	½ (13) <sup>B</sup>
41 to 125 (5 to 51)	polyimide foam, C 1482, Type I with vapor retarder	1 (25)	¾ (19) <sup>B</sup>
	cellular glass, C 552, Type I	1 (25)	½ (13) <sup>B</sup>
	mineral fiber blanket, C 553, C 612	1 (25)	¾ (19) <sup>B</sup>

<sup>A</sup>Nominal thickness exclusive of vapor retarder.

<sup>B</sup>Thickness for application in air-conditioned spaces only.



**TABLE 12 Thickness of Insulating Materials for Hot Surfaces of Machinery and Equipment, 126 to 1200°F (52 to 649°C)**

Material	Maximum Temperature, °F (°C) × Thickness, in. (mm) <sup>A</sup>									
	150 (66)	250 (121)	350 (177)	450 (232)	550 (288)	650 (343)	750 (399)	850 (454)	950 (510)	1050 (566)
Fibrous glass felt, MIL-I-16411, Type II	1 (25)	1 (25)	1½ (38)	2½ (63)	3 (76)	4 (102)	4 (102)	5 (127)	5½ (140)	6½ (165)
Block calcium silicate, C 533	1½ (38)	1½ (38)	2 (51)	2½ (63)	4 (102)	4 (102)	4 (102)	5 (127)	5 (127)	5½ (140)
Block perlite, C 610	1½ (38)	1½ (38)	2 (51)	2½ (63)	4 (102)	4 (102)	4 (102)	5 (127)	5 (127)	5½ (140)
Refractory fiber, C 892, Grade 6	1 (25)	1 (25)	2 (51)	2½ (63)	3½ (89)	4½ (114)	4½ (114)	5½ (140)	6 (152)	7½ (191)
Refractory fiber, C 892 Grade 8	1 (25)	1 (25)	1½ (38)	2½ (63)	3 (76)	4 (102)	4 (102)	5 (127)	6 (152)	7 (178)
Mineral fiber, <sup>B</sup> C 553	1½ (38)	1½ (38)	2 (51)	2½ (63)	3½ (89)	3½ (89)	3½ (89)	4 (102)	4½ (114)	5 (127)
Elastomeric foam, <sup>C</sup> C 534, Type II	½ (13)	½ (13)								
Polyimide foam, C 1482 <sup>D</sup>	¾ (19)		1½ (38)	2 (51)						
Insulating cement, <sup>E</sup> C 195	2 (51)	2 (51)	2½ (63)	3½ (89)	5 (127)	5 (127)	5 (127)	5½ (140)		

<sup>A</sup>Does not include finishing cement.  
<sup>B</sup>1000°F (537°C) maximum temperature.  
<sup>C</sup>180°F (82°C) maximum temperature.  
<sup>D</sup>Not to be used alone above 850°F (454°C).  
<sup>E</sup>See Supplementary Requirements S1.15.

**TABLE 13 Metal Lagging Materials<sup>A</sup>**

Material	Specification	Nominal Thickness, in. (mm)
Hot-dipped galvanized steel	A 526/A 526M Coating designation G-115	0.014 (0.356)
Aluminum	B 209, 6061	0.030 (0.762)
Corrosion-resistant steel	A 167, Type 304	0.014 (0.356)

<sup>A</sup> For use on piping and machinery insulation in locations where insulation is subject to abuse, except for uptake applications in which metal lagging shall be galvanized steel, Specification A 526/A 526M, Coating Designation G-115, not less than ½ in. (0.795 mm) thick.

7.1.3 For installation details, see Fig. 9, Fig. 10, or Fig. 11, as applicable.

7.2 *Temperature Range from 41 to 125°F (5 to 52°C)*—Use for low-temperature machinery and equipment within the temperature range.

7.2.1 For insulation and lagging materials, see Table 3.

7.2.2 For insulation thickness, see Table 11.

7.2.3 For installation details, see Fig. 9, Fig. 10, Fig. 11, or Fig. 12, as applicable.

7.2.4 *Special Conditions*—Machinery or equipment operating in this temperature range does not require insulation except where damage or discomfort may result from condensation.

7.3 *Temperature Range from 126 to 1200°F (52 to 649°C)*—Use for medium- and high-temperature machinery and equipment within the temperature range.

7.3.1 For insulation and lagging materials, see Table 3.

7.3.2 For insulation thickness, see Table 12.

7.3.3 For installation details, see Fig. 10, Fig. 11, Fig. 12, Fig. 13, or Fig. 14, as applicable.

## 8. Insulation and Lagging Requirements for Removable Covers for Valves, Fittings, Flanges, and Machinery or Equipment

8.1 *Removable Covers*—Flanged valves and fittings and pipeline flanges shall have removable covers to permit servicing of takedown joints.

8.1.1 Removable covers shall be manufactured using materials specified in 8.2-8.4 and to thicknesses specified in Tables 4-7. Stitching, lacing, and quilting (required to prevent sagging) shall be accomplished with materials specified in 8.5 and as shown in Figs. 15-17.

8.1.2 Removable covers may also be manufactured from segments of block insulation or from preformed sectional pipe covering and molded (premolded) components. When a removable cover is made of segments of block insulation or preformed (pre-molded) sectional pipe covering, it shall be of the same material and thickness as the adjoining pipe insulation.

### 8.2 Filler Materials for Removable Blankets:

8.2.1 Fibrous glass felt, conforming with MIL-I-16411, Type II.

8.2.2 Refractory fiber blanket, in accordance with Specification C 892, Grade 8.

8.2.3 Refractory fiber blanket, also in accordance with Specification C 892, Grade 6.

8.2.4 Mineral fiber blanket, in accordance with Specification C 612, Class 4.

### 8.3 Covering or Encapsulating Materials for Removable Blankets:

8.3.1 For surface temperatures 450°F (232°C) and below, the filler shall be encapsulated with fiberglass cloth, conforming with MIL-C-20079, Type I, Class 9 (see Fig. 18, Detail A).

8.3.2 For surface temperatures above 450°F (232°C), the entire outside surface shall be encapsulated with TY304 stainless steel wire mesh, 0.011-in. (0.25 mm) diameter, No. 60 density, and crimped (see Fig. 18, Detail B). Alternatively, the entire outside surface may be encapsulated with fiberglass cloth, inserted with stainless steel reinforcement, in accordance with HH-P-31, Type I, Class 1.

8.3.3 The cold or top side of the surface shall be covered with fiberglass cloth, conforming with MIL-C-20079, Type I, Class 9. The bottom and side surface areas shall be covered as follows:

8.3.3.1 Fiberglass cloth, shall be inserted with stainless steel wire reinforcement, conforming with HH-P-31, Type I, Class 1 (see Fig. 18, Detail C); or

8.3.3.2 Fiberglass cloth, conforming with MIL-C-20079, Type I, Class 9, with TY304 stainless steel wire mesh, 0.008-in. (0.21-mm) diameter and No. 60 density, shall be crimped sewn onto the fibrous cloth (see Fig. 18, Detail D); or

8.3.3.3 TY304 stainless steel wire mesh, 0.011-in. (0.25-mm) diameter and No. 60 density, shall be crimped (see Fig. 18, Detail E).





**TABLE 14 Thickness of Fiberglass Felt for Removable Insulation Blankets<sup>A</sup>**

Nominal Pipe Size, in. (mm)	Maximum Temperature, °F (°C) × Thickness, in. (mm)									
	150 (66)	250 (121)	350 (177)	450 (232)	550 (288)	650 (343)	750 (399)	850 (454)	950 (510)	1050 (566)
½ (13)	1 (25)	1 (25)	1½ (38)	1½ (38)	2 (51)	2 (51)	2½ (63)	2½ (63)	3 (76)	3½ (89)
1 (25)	1 (25)	1 (25)	1 (25)	1½ (38)	2 (51)	2 (51)	2½ (63)	3 (76)	3 (76)	3½ (89)
1½ (38)	1 (25)	1 (25)	1 (25)	1½ (38)	2 (51)	2½ (63)	2½ (63)	3 (76)	3½ (89)	4 (102)
2 (51)	1 (25)	1 (25)	1 (25)	1½ (38)	2 (51)	2½ (63)	2½ (63)	3 (76)	3½ (89)	4 (102)
3 (76)	1 (25)	1 (25)	1 (25)	1½ (38)	2 (51)	2½ (63)	3 (76)	3½ (89)	4 (102)	4½ (114)
4 (102)	1 (25)	1 (25)	1½ (38)	2 (51)	2½ (63)	3 (76)	3 (76)	3½ (89)	4 (102)	5 (127)
6 (152)	1 (25)	1 (25)	1½ (38)	2 (51)	2½ (63)	3 (76)	3 (76)	4 (102)	4½ (114)	5½ (140)
8 (203)	1 (25)	1 (25)	1½ (38)	2 (51)	2½ (63)	3 (76)	3½ (89)	4 (102)	5 (127)	5½ (140)
10 (254)	1 (25)	1 (25)	1½ (38)	2 (51)	2½ (63)	3½ (89)	3½ (89)	4 (102)	5 (127)	6 (152)
12 (305)	1 (25)	1 (25)	1½ (38)	2 (51)	2½ (63)	3½ (89)	3½ (89)	4½ (114)	5 (127)	6 (152)
14 (356)	1 (25)	1 (25)	1½ (38)	2 (51)	2½ (63)	3½ (89)	3½ (89)	4½ (114)	5½ (140)	6 (152)
16 (406)	1 (25)	1 (25)	1½ (38)	2 (51)	3 (76)	3½ (89)	3½ (89)	4½ (114)	5½ (140)	6½ (165)
18 (457)	1 (25)	1 (25)	1½ (38)	2 (51)	3 (76)	3½ (89)	4 (102)	4½ (114)	5½ (140)	6½ (165)

<sup>A</sup>Thickness of fiberglass felt, in accordance with MIL-I-16411, Type II.

**TABLE 15 Thickness of 8-lb/ft<sup>3</sup> (128-kg/m<sup>3</sup>) Refractory Fiber Blanket for Removable Insulation Blankets<sup>A</sup>**

Nominal Pipe Size, in. (mm)	Maximum Temperature, °F (°C) × Thickness, in. (mm)									
	150 (66)	250 (121)	350 (177)	450 (232)	550 (288)	650 (343)	750 (399)	850 (454)	950 (510)	1050 (566)
½ (13)	1 (25)	1 (25)	1 (25)	1½ (38)	1½ (38)	2 (51)	2 (51)	2½ (63)	3 (76)	3 (76)
1 (25)	1 (25)	1 (25)	1 (25)	1½ (38)	2 (51)	2 (51)	2½ (63)	3 (76)	3 (76)	3½ (89)
1½ (38)	1 (25)	1 (25)	1 (25)	1½ (38)	2 (51)	2½ (63)	2½ (63)	3 (76)	3½ (89)	4 (102)
2 (51)	1 (25)	1 (25)	1 (25)	1½ (38)	2 (51)	2½ (63)	2½ (63)	3 (76)	3½ (89)	4 (102)
3 (76)	1 (25)	1 (25)	1½ (38)	2 (51)	2½ (63)	3 (76)	3 (76)	3½ (89)	4 (102)	4½ (114)
4 (102)	1 (25)	1 (25)	1½ (38)	2 (50)	2½ (63)	3 (76)	3 (76)	3½ (89)	4 (102)	4½ (114)
6 (152)	1 (25)	1 (25)	1½ (38)	2 (51)	2½ (63)	3 (76)	3 (76)	4 (102)	4½ (114)	5 (127)
8 (203)	1 (25)	1 (25)	1½ (38)	2 (51)	2½ (63)	3½ (89)	3½ (89)	4 (102)	4½ (114)	5½ (140)
10 (254)	1 (25)	1 (25)	1½ (38)	2 (51)	3 (76)	3½ (89)	3½ (89)	4 (102)	5 (127)	5½ (140)
12 (305)	1 (25)	1 (25)	1½ (38)	2 (51)	3 (76)	3½ (89)	3½ (89)	4½ (114)	5 (127)	6 (152)
14 (356)	1 (25)	1 (25)	1½ (38)	2 (51)	3 (76)	3½ (89)	3½ (89)	4½ (114)	5 (127)	6 (152)
16 (406)	1 (25)	1 (25)	1½ (38)	2 (51)	3 (76)	3½ (89)	3½ (89)	4½ (114)	5 (127)	6 (152)
18 (457)	1 (25)	1 (25)	1½ (38)	2½ (63)	3 (76)	3½ (89)	4 (102)	4½ (114)	5½ (140)	6 (152)

<sup>A</sup>Thickness of 8-lb/ft<sup>3</sup> (128-kg/m<sup>3</sup>) refractory fiber blanket in accordance with Specification C 892, Grade 8.

**TABLE 16 Thickness of 6-lb/ft<sup>3</sup> (96-kg/m<sup>3</sup>) Refractory Fiber Blanket for Removable Insulation Blankets<sup>A</sup>**

Nominal Pipe Size, in. (mm)	Maximum Temperature, °F (°C) × Thickness, in. (mm)									
	150 (66)	250 (121)	350 (177)	450 (232)	550 (288)	650 (343)	750 (399)	850 (454)	950 (510)	1050 (566)
½ (13)	1 (25)	1 (25)	1 (25)	1½ (38)	1½ (38)	2 (51)	2 (51)	2½ (63)	2½ (63)	3 (76)
1 (25)	1 (25)	1 (25)	1 (25)	1½ (38)	2 (51)	2½ (63)	2½ (63)	2½ (63)	3 (76)	3½ (89)
1½ (38)	1 (25)	1 (25)	1½ (38)	1½ (38)	2 (51)	2½ (63)	2½ (63)	2½ (63)	3 (76)	4 (102)
2 (51)	1 (25)	1 (25)	1½ (38)	1½ (38)	2 (51)	2½ (63)	2½ (63)	3 (76)	3½ (89)	4 (102)
3 (76)	1 (25)	1 (25)	1½ (38)	2 (51)	2½ (63)	3 (76)	3 (76)	3½ (89)	4 (102)	4½ (114)
4 (102)	1 (25)	1 (25)	1½ (38)	2 (51)	2½ (63)	3 (76)	3 (76)	3½ (89)	4½ (114)	5 (127)
6 (152)	1 (25)	1 (25)	1½ (38)	2 (51)	2½ (63)	3½ (89)	3½ (89)	4 (102)	4½ (114)	5½ (140)
8 (203)	1 (25)	1 (25)	1½ (38)	2 (51)	2½ (63)	3½ (89)	3½ (89)	4 (102)	5 (127)	5½ (140)
10 (254)	1 (25)	1 (25)	1½ (38)	2 (51)	3 (76)	3½ (89)	3½ (89)	4½ (114)	5 (127)	6 (152)
12 (305)	1 (25)	1 (25)	1½ (38)	2½ (63)	3 (76)	3½ (89)	4 (102)	4½ (114)	5½ (140)	6 (152)
14 (356)	1 (25)	1 (25)	2 (51)	2½ (63)	3 (76)	3½ (89)	4 (102)	4½ (114)	5½ (140)	6½ (165)
16 (406)	1 (25)	1 (25)	2 (51)	2½ (63)	3 (76)	3½ (89)	4 (102)	4½ (114)	5½ (140)	6½ (165)
18 (457)	1 (25)	1 (25)	2 (51)	2½ (63)	3½ (89)	3½ (89)	4 (102)	5 (127)	6 (152)	6½ (165)

<sup>A</sup>Thickness of 6-lb/ft<sup>3</sup> (96-kg/m<sup>3</sup>) refractory fiber blanket in accordance with Specification C 892, Grade 6.

8.4 *Alternative Covering Materials* (for surface temperatures 450°F (232°C) and below, and for cold or top-side covering for temperatures above 450°F), are provided for removable blankets to be used in areas exposed to weather or where liquid penetration could present a fire hazard. Alternative coverings are as follows:

- 8.4.1 Silicone-impregnated fiberglass cloth,
- 8.4.2 Silicone-impregnated fiberglass cloth with aluminized facing on one side, and
- 8.4.3 Fiberglass cloth with aluminum or stainless steel facing laminated to one side.

8.5 *Hardware and Accessory Items for Removable Blanket Construction*—Necessary items shall include blanket lacing

devices, blanket quilting devices, stitching materials, and installation materials.

8.5.1 *Blanket Lacing Devices:*

- 8.5.1.1 TY304 stainless steel lacing rings with lacing washers (see Fig. 19).
- 8.5.1.2 TY304 stainless steel lacing hooks with lacing washers (see Fig. 20).
- 8.5.1.3 TY303 stainless steel lacing capstan assembly sets (see Fig. 21).
- 8.5.1.4 TY304 stainless steel mechanical hook sets (see Fig. 22).

8.5.2 *Blanket Quilting Devices:*

**TABLE 17 Thickness of Fiberglass Blanket for Removable Insulation Blankets<sup>A</sup>**

Nominal Pipe Size, in. (mm)	Maximum Temperature, °F (°C) × Thickness, in. (mm)							
	150 (66)	250 (121)	350 (177)	450 (232)	550 (288)	650 (343)	750 (399)	850 (454)
½ (13)	½ (13)	½ (13)	1 (25)	1 (25)	1½ (38)	2 (51)	2½ (63)	3 (76)
1 (25)	½ (13)	½ (13)	1 (25)	1½ (38)	2 (51)	2 (51)	2½ (63)	3 (76)
1½ (38)	½ (13)	½ (13)	1 (25)	1½ (38)	2 (51)	2 (51)	3 (76)	3½ (89)
2 (51)	½ (13)	½ (13)	1 (25)	1½ (38)	2 (51)	2 (51)	3 (76)	4 (102)
3 (76)	½ (13)	½ (13)	1 (25)	1½ (38)	2 (51)	2 (51)	3 (76)	4 (102)
4 (102)	½ (13)	½ (13)	1 (25)	1½ (38)	2½ (63)	2½ (63)	3½ (89)	4½ (114)
6 (152)	½ (13)	½ (13)	1 (25)	2 (51)	2½ (63)	2½ (63)	3½ (89)	5 (127)
8 (203)	½ (13)	½ (13)	1 (25)	2 (51)	2½ (63)	2½ (63)	4 (102)	5 (127)
10 (254)	½ (13)	½ (13)	1½ (38)	2 (51)	2½ (63)	2½ (63)	4 (102)	5½ (140)
12 (305)	½ (13)	1 (25)	1½ (38)	2 (51)	2½ (63)	2½ (63)	4 (102)	5½ (140)
14 (356)	½ (13)	1 (25)	1½ (38)	2 (51)	3 (76)	4 (102)	4 (102)	5½ (140)
16 (406)	½ (13)	1 (25)	1½ (38)	2 (51)	3 (76)	4 (102)	4½ (114)	5½ (140)
18 (457)	½ (13)	1 (25)	1½ (38)	2 (51)	3 (76)	4 (102)	4½ (114)	6 (152)

<sup>A</sup>Thickness of fiberglass blanket, in accordance with Specification C 612, Type II, C 553, Type IV.

8.5.2.1 TY304 stainless steel mechanical quilt sets (see Fig. 23).

8.5.2.2 TY304 stainless steel lacing washers with lacing wire (see Fig. 23).

**8.5.3 Stitching Materials:**

8.5.3.1 TY304 stainless steel hog rings.

8.5.3.2 TY304 stainless steel thread (0.011-in. (0.25-mm) diameter).

8.5.3.3 TY304 stainless steel staples.

8.5.3.4 Fiberglass thread (plain, polytetrafluoroethylene coated and wire inserted with monel or TY304 stainless steel, or both).

**8.5.4 Installation Materials:**

8.5.4.1 No. 18 gage copper lacing wire.

8.5.4.2 No. 18 gage soft or annealed TY304 stainless steel lacing wire.

8.5.4.3 No. 18 gage galvanized iron lacing wire.

8.5.4.4 TY304 stainless steel hog rings (particularly for installing thermal tape, refer also to Section 9).

**8.6 Special Conditions:**

8.6.1 Reuseable covers for machinery and equipment shall be fabricated from materials specified in Tables 14-17, in accordance with methods shown in Fig. 18 and configured to suit the specific application.

8.6.2 Unfired pressure vessels with butt welded inserts for which periodic radiographic inspection of the joint is required should have removable reuseable covers installed over the insert. These covers should extend 4 in. (100 mm) beyond the weld joint.

8.6.3 Removable covers shall not be used on systems

insulated with elastomeric-foamed plastic insulation.

8.6.4 Services subject to frequent maintenance, such as reducing and regulating valves, shall be provided with easily removed and replaced tailored pads.

8.6.5 Removable blankets should not be used on cold systems (below ambient) or on systems where a vapor barrier is required.

8.6.6 When stitching two or more covering or encapsulating materials together, stainless steel staples, hog rings, 0.011-in. (0.25-mm) diameter stitching wire, or fiberglass thread (plain or wire inserted) may be used.

8.6.7 All construction details apply to removable blankets for flanges, valves, machinery and equipment, and other miscellaneous areas as determined by the specifier.

8.6.8 When installing removable blankets on valves, flanges, and various pieces of equipment, note that all void areas behind the insulation blanket are to be filled. The total required thickness of insulation shall not be achieved by including a loose wrap of fibrous glass felt or refractory fiber blanket as part of the required thickness.

**9. Requirements for Thermal Insulating Tape**

9.1 *Thermal Insulating Tape*—May be applied to pipe, sizes ¼ in. (8 mm) to ¾ in. (20 mm), for temperatures between 125 and 150°F (52 and 66°C) using materials specified in Section 8 and to thicknesses specified in Table 14. For manufacturing and installation details, see Fig. 6.

9.2 *Filler Materials for Thermal Insulating Tape*—See 8.2.

9.3 *Covering or Encapsulating Materials for Thermal Insulating Tape:*

9.3.1 For surface temperatures below 220°F (105°C), the entire outside surface shall be encapsulated with fiberglass cloth, conforming with MIL-C-20079, Type I, Class 3.

9.3.2 For surface temperatures 220 to 450°F (105 to 232°C), the entire outside surface shall be encapsulated with fiberglass cloth, conforming with MIL-C-20079, Type I, Class 9.

9.3.3 For surface temperatures above 450°F (232°C), the entire outside surface shall be encapsulated with fiberglass cloth, conforming with MIL-C-20079, Type I, Class 9, with an inner jacket of TY304 stainless steel wire mesh, 0.008-in. (0.21-mm) diameter, No. 60 density and crimped. Alternatively, the entire outside surface may be encapsulated with fiberglass cloth, inserted with stainless steel wire reinforcement, in accordance with HH-P-31, Type I, Class 1.

9.4 *Hardware and Accessory Items for Thermal Insulating Construction*—See 8.5.

9.5 *Special Conditions*—See 8.6.

**10. Keywords**

10.1 insulation; lagging; machinery insulation; marine; piping insulation; ship; shipboard insulation; thermal insulation; vessel

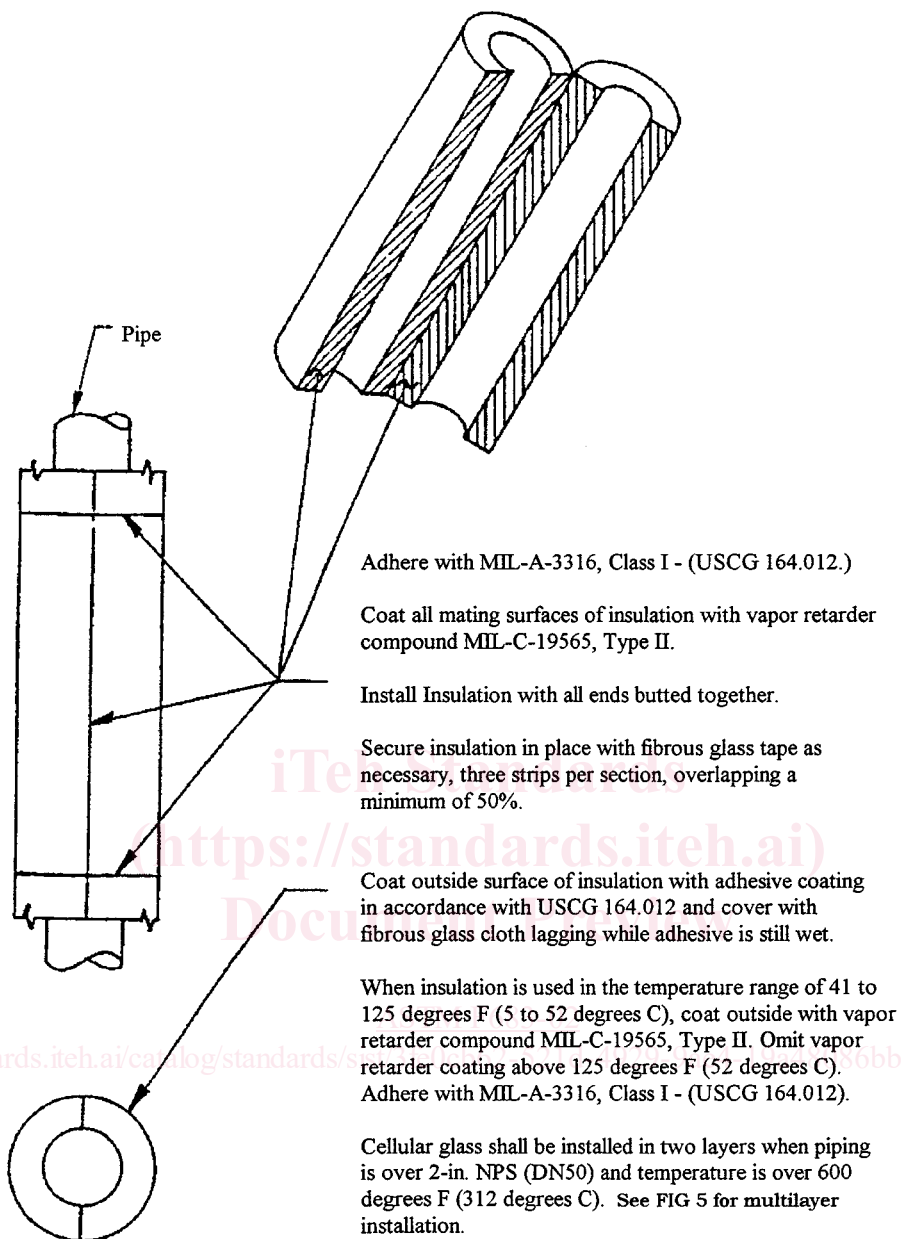

**FIG. 1 Installation of Cellular Glass Pipe Insulation (Specification C 552)**