



Designation: D7038 – 14

# Standard Test Method for Evaluation of Moisture Corrosion Resistance of Automotive Gear Lubricants<sup>1</sup>

This standard is issued under the fixed designation D7038; the number immediately following the designation indicates the year of original adoption or, in the case of revision, the year of last revision. A number in parentheses indicates the year of last reapproval. A superscript epsilon ( $\epsilon$ ) indicates an editorial change since the last revision or reapproval.

## 1. Scope\*

1.1 This test method covers a test procedure for evaluating the rust and corrosion inhibiting properties of a gear lubricant while subjected to water contamination and elevated temperature in a bench-mounted hypoid differential housing assembly.<sup>2</sup> This test method is commonly referred to as the L-33-1 test.

1.2 The values stated in inch-pound units are to be regarded as standard. The values given in parentheses are mathematical conversions to SI units that are provided for information only and are not considered standard.

1.2.1 *Exceptions*—(1) where there is no direct SI equivalent such as screw threads and national pipe threads/diameters, and (2) the values stated in SI units are to be regarded as standard for the definitions in 12.2, and for SI units where there are no direct inch-pounds equivalent units.

1.3 *This standard does not purport to address all of the safety concerns, if any, associated with its use. It is the responsibility of the user of this standard to establish appropriate safety and health practices and determine the applicability of regulatory limitations prior to use.*

## 2. Referenced Documents

2.1 *ASTM Standard*:<sup>3</sup>

D235 Specification for Mineral Spirits (Petroleum Spirits) (Hydrocarbon Dry Cleaning Solvent)

<sup>1</sup> This test method is under the jurisdiction of ASTM Committee D02 on Petroleum Products, Liquid Fuels, and Lubricants and is the direct responsibility of Subcommittee D02.B0 on Automotive Lubricants.

Current edition approved Oct. 1, 2014. Published October 2014. Originally approved in 2004. Last previous edition approved in 2013 as D7038 – 13. DOI: 10.1520/D7038-14.

<sup>2</sup> Until the next revision of this test method, the ASTM Test Monitoring Center (TMC) will update changes in this test method by means of Information Letters. This edition includes all Information Letters through 14–01. Information Letters may be obtained from the ASTM TMC, 6555 Penn Ave., Pittsburgh, PA 15206-4489, Attention: Administrator. The TMC is also the source of reference oils.

<sup>3</sup> For referenced ASTM standards, visit the ASTM website, www.astm.org, or contact ASTM Customer Service at service@astm.org. For *Annual Book of ASTM Standards* volume information, refer to the standard's Document Summary page on the ASTM website.

2.2 *Society of Automotive Engineers Standards*:<sup>4</sup>

J308 Information Report on Axle and Manual Transmission Lubricants

J2360 Lubricating Oil, Gear Multipurpose (Metric) Military Use

2.3 *U.S. Military Specifications*:<sup>5</sup>

MIL-PRF-2105E Lubricating Oil, Gear, General Multipurpose

MIL-P-3420F NOX-RUST Paper

## 3. Terminology

3.1 *Definitions of Terms Specific to This Standard*:

3.1.1 *corrosion, n*—an alteration of a finished metal surface by discoloration, accompanied by roughening not attributable to mechanical action.

3.1.2 *downtime, n*—an interruption of power to the test unit for a period greater than ten seconds.

3.1.3 *rust, n*—a special case of corrosion, which always deteriorates or alters the original surface condition.

3.1.3.1 *Discussion*—Rust always has color (usually, but not limited to red, yellow, brown, black) and one of the following descriptive characteristics: (1) depth; the rusted surface is built up relative to that of adjacent areas. (2) texture; the surface may appear to be etched, scaly or otherwise visibly different than adjacent areas.

3.1.4 *stain, n*—a surface modification that is attributable to discoloration only.

## 4. Summary of Test Method

4.1 This procedure utilizes a Dana Corporation Model 30 hypoid differential assembly, Part No. 27770–1X, 4:10 ratio, standard differential with uncoated ring and pinion, without axle tubes.<sup>6,7</sup>

<sup>4</sup> Available from Society of Automotive Engineers (SAE), 400 Commonwealth Dr., Warrendale, PA 15096-0001.

<sup>5</sup> Available from the Defense Printing Service Office, 700 Robbins Ave., Bldg. 4D, Philadelphia, PA 19111-5094.

<sup>6</sup> The sole source of supply of the apparatus known to the committee at this time is Spicer Axle Division, Dana Corporation, P.O. Box 1209, Fort Wayne, IN 46801.

\*A Summary of Changes section appears at the end of this standard

4.2 *Test Unit Preparation*—Prior to each test, completely disassemble and clean the new differential housing assembly. Discard the axle spacer block. Abrasive blast all rated parts (except bearings and cups). Disassemble all bearings from their mating parts prior to abrasive blasting. Coat all internal parts and rated surfaces with test oil. Reassemble the unit to test specification values. Install the unit on the motoring rig and then connect an oil temperature monitoring probe and a drive shaft. Place a cooling fan and heat lamps into position near the test unit.

4.3 *Motoring Phase*—Charge the test unit with 40 oz (1.2 L) of test oil. Drive the test unit with an electric motor at 2500 r/min pinion speed in an unloaded condition (no axle shafts are used for the test). Add 1 oz (30 mL) of specified test water into the oil fill opening (all other test unit openings having been already sealed). Install the pressure relief system and set to 1 psi (7 kPa). Plug the relief system when the lubricant temperature reaches 180°F (82.2 °C). Continue the motoring phase for 4 h at this controlled temperature.

4.4 *Storage Phase*—Stop the motor at the completion of the motoring phase. Remove the test unit from the motoring rig and place in a storage box at 125°F (52 °C) for 162 h.

4.5 *Inspection*—At the end of the storage phase, the test is complete. Drain the differential assembly, disassemble, and rate for rust, stain, and other deposits.

## 5. Significance and Use

5.1 This test simulates a type of severe field service in which corrosion-promoting moisture in the form of condensed water vapor accumulates in the axle assembly. This may happen as a result of volume expansion and contraction of the axle lubricant and the accompanied breathing in of moisture-laden air through the axle vent. The test screens lubricants for their ability to prevent the expected corrosion.

5.2 The test method described in this standard may be used by any properly equipped laboratory, without the assistance of anyone not associated with that laboratory. However, the ASTM Test Monitoring Center (TMC) provides reference oils and an assessment of the test results obtained on those oils by the laboratory (see [Annex A7](#)). By this means, the laboratory will know whether their use of the test method gives results statistically similar to those obtained by other laboratories. Furthermore, various agencies require that a laboratory utilize the TMC services in seeking qualification of oils against specifications. For example, the U.S. Army imposes such a requirement in connection with several Army lubricating oil specifications.

5.3 The L-33-1 test procedure is used or referred to in the following documents: ASTM Publication STP-512A,<sup>8</sup> SAE J308, SAE J2360, and U.S. Military Specification MIL-PRF-2105E.

<sup>7</sup> If you are aware of alternative suppliers, please provide this information to ASTM International Headquarters. Your comments will receive careful consideration at a meeting of the responsible technical committee,<sup>1</sup> which you may attend.

<sup>8</sup> ASTM Publication STP-512A, *Laboratory Performance Tests for Automotive Gear Lubricants Intended for API GL-5 Service*, ASTM International, West Conshohocken, PA.

## 6. Apparatus

### 6.1 Laboratory Ambient Conditions:

6.1.1 *Test Operating Area*—The ambient laboratory atmosphere shall be free of dirt, dust, and other contaminants as required by good laboratory standards.

6.1.2 *Cleaning and Abrasive Blasting (6.2.8) Areas*—Provide adequate ventilation in areas where solvents (7.2) are used. (**Warning**—Combustible, vapor harmful.)

6.1.3 *Build-up Area*—It is recommended that the atmosphere in the test unit build-up area be filtered and maintained at uniform temperature and low humidity to prevent accumulation of dirt or rust on test parts. Otherwise it shall conform to requirements of 6.1.1.

6.1.4 *Parts Rating Area*—Conduct the rating of all test parts under conditions as defined in ASTM Distress Rating Manual 21.<sup>9</sup>

### 6.2 Motoring Rig, Test Unit and Laboratory Equipment:

6.2.1 *Test Unit Configuration*—Mount the differential housing assembly (Gear version 99.1 or V01.1) on the motoring rig so that the housing cover attaching face is in the vertical plane and at a height that allows the temperature sensing probe to be located in the bottom of the housing. Elements of the motoring rig design are shown in [Figs. A1.1-A1.4](#).

6.2.2 *Drive System*—The drive system design is not precisely specified; however, the following equipment or its equivalent have been found to be suitable to turn the drive pinion at the specified (2500 ± 25) r/min. (**Warning**—Rotating test stand equipment presents a physical hazard, use safety guards.)

6.2.2.1 *U.S. Motors*, 1.5 hp (1.1 kW) electric motor, enclosed, 3600 r/min, 0.87 in. (22.2 mm) diameter shaft.<sup>10,7</sup>

6.2.2.2 *Slide Motor Base*, Dyn-Adjust No. 20-C.<sup>10,7</sup>

6.2.2.3 *Dodge Taper Lock Pulleys*, No. 40L100 (Driven) and No. 28L100 (Drive).<sup>10,7</sup>

6.2.2.4 *Dodge Timing Belt*, No. 480L100.<sup>10,7</sup>

6.2.2.5 Additional components such as shafts, couplings, and bearing blocks are also necessary to connect the above components to drive the carrier pinion, but are left to the option of the testing laboratory.

6.2.3 *Vapor Pressure Control System*—Control the internal vapor pressure of the unit during the warm-up portion of the motoring phase with a specified water column pressure relief system set for 1.0 ± 0.1 psi (7 kPa ± 0.7 kPa) connected to the housing cover with an appropriately sized National Pipe Threads (NPT) stainless steel 90° street ell and a stainless steel full port valve. The system shall contain an oil trap and return vessel to return test oil to the unit in case of foaming, and a water trap and return vessel to prevent column water from moving back to test unit. The example set up in [Fig. A1.1](#) has been shown to be acceptable.

<sup>9</sup> For stock #TMCML21, visit the ASTM website, [www.astm.org](http://www.astm.org), or contact ASTM Customer Service at [service@astm.org](mailto:service@astm.org).

<sup>10</sup> The sole source of supply of the apparatus known to the committee at this time is a Power Drive Parts Distributor.

6.2.4 *Housing Cover Gasket*—Replace the factory-supplied gasket with a single TFE fluorocarbon gasket for every test.<sup>11,7</sup>

6.2.5 *Housing Axle Tube Opening Seals*—Since the differential is tested without axle shafts or axle tubes, seal the housing openings. Fig. A1.2 shows an example of construction dimensions for fabricating a pair of seals to be installed in the axle housing openings before introducing test oil prior to starting the test.

6.2.6 *Temperature Control System, Motoring Phase*—During the motoring phase, the bulk oil temperature is sensed by a resistance temperature device (RTD) or thermocouple (J or K type). The controller switches on a pair of 250 W lamps or cooling fan, or both, that are directed toward the differential as needed to control bulk oil temperature at  $180 \pm 1^\circ\text{F}$  ( $82 \text{ }^\circ\text{C} \pm 6 \text{ }^\circ\text{C}$ ). A household-type electric fan having 12.0-in. (310 mm) diameter blades has been shown to provide acceptable cooling capability. Fig. A1.3 shows an example of the location of the heat lamp pair and the cooling fan. Fig. A1.4 shows the location of the temperature sensor in the differential housing.

6.2.7 *Storage Box and Temperature Control System, Storage Phase*—During the storage phase of the test, a double-walled aluminum or stainless steel box covers the differential housing assembly. An RTD or thermocouple (J or K type) in conjunction with the controller regulates heat input from four strip heaters giving a total output of 1700 Btu/h (500 W). A small electric fan, rated at 1550 r/min, turns a fabricated impeller at  $(1700 \pm 100)$  r/min to provide air circulation within the box. Control the bulk oil temperature at  $125 \pm 1^\circ\text{F}$  ( $52 \text{ }^\circ\text{C} \pm 6 \text{ }^\circ\text{C}$ ). Fig. A1.5 shows details of the impeller. Fig. A1.6 shows construction and electrical details of this box.

NOTE 1—Insulation on the outside surface of the box only may be necessary to maintain test temperature specifications.

6.2.8 *Abrasive Blasting*—Blast the entire differential case, ring, pinion, side gears, differential pinion gears (spider gears), all four thrust washers and the inside surface of the differential housing cover plate with 80 grit aluminum oxide so as to remove pre-existing corrosion and produce a uniform surface. Do not abrasive blast the bearings, bearing cups and differential shaft (cross shaft pin). (**Warning**—Provide adequate safety equipment for abrasive blasting operations.)

6.2.9 The following specifies the abrasive blasting equipment and material:

6.2.9.1 *Abrasive Blasting Cabinet*—Grainger Econo-Line 36 in. by 24 in., Grainger Item No. 3Z850.<sup>12,7</sup>

(1) Use solely for cleaning L-33-1 test units.

(2) Measure air pressure for the blasting gun at the regulator just prior to entering the cabinet enclosure. Set the regulator to maintain  $80 \pm 2$  psig ( $552 \text{ kPa} \pm 14 \text{ kPa}$ ) while flowing abrasive material.

6.2.9.2 *Dust Collector*—Grainger Econo-Line 1000 ft<sup>3</sup>/min, Grainger Item No. 3JR93.<sup>12,7</sup>

6.2.9.3 *Blasting Gun Setup*:

(1) Grainger Econo-Line 12 ft<sup>3</sup>/min Gun Assembly, Grainger Item No. 3JT01.<sup>12,7</sup>

(2) Grainger Econo-Line tungsten carbide Nozzle Tip ¼ in. I.D.

(3) Grainger Item No. 3JT0813, Change after fifteen L-33-1 units are blasted.

(4) Grainger Econo-Line Air Jet 12 ft<sup>3</sup>/min, Grainger Item No. 3JT04.<sup>12,7</sup>

6.2.9.4 *Abrasive Blasting Material*—Alodur Fused Brown Aluminum Oxide,<sup>13,7</sup> 80 grit—ANSI Table 3 Grade.<sup>14,7</sup> Change the entire cabinet supply of abrasive blasting material after 15 L-33-1 units are blasted. (**Warning**—Abrasive blasting presents a physical hazard; consult and follow equipment manufacturer's precautions.)

## 7. Reagents and Materials

7.1 *Specified Test Water*—Fisher Scientific deionized ultra filtered water, Part No. W2-4 or W2-20.<sup>15,7</sup>

7.2 *Solvent*—Use only mineral spirits meeting the requirements of Specification D235, Type II, Class C for Aromatic Content (0 to 2) vol (%), Flash Point ( $142^\circ\text{F}/61 \text{ }^\circ\text{C}$ , min) and Color (not darker than +25 on Saybolt Scale or 25 on Pt-Co Scale). (**Warning**—Combustible. Health hazard.) Obtain a Certificate of Analysis for each batch of solvent from the supplier.

7.3 *Rust Prevention Oil*—Mobil Arma 245.<sup>16,7</sup> (**Warning**—Combustible mixture. Harmful or fatal if swallowed.)

7.4 *Build-up Lubricant*—Use test oil for test unit build-up.

## 8. Test Oil

8.1 Use 1.0 gal (3.7 L) for each test. The housing capacity is 2.5 pt (1.2 L); the remaining oil is used for coating the test parts during assembly.

## 9. Preparation of Apparatus

9.1 *Test Unit Preparation*:

9.1.1 *Cleaning of Reused Fittings, Seals, and so forth*—Clean, as necessary, all reusable parts including axle tube opening seals, pressure relief system and elbow, and the temperature sensor and its fittings.

9.2 *Differential Assembly Build-Up*:

9.2.1 *Cleaning and Preparation of Parts*:

9.2.1.1 *Disassembly*—Completely disassemble the differential housing assembly and remove all parts from the differential case. Discard the axle spacer block, which is not used in the

<sup>11</sup> The sole source of supply of the apparatus known to the committee at this time is AP Services Inc., 203 Armstrong Drive, Northpoint Industrial Park, Freeport, PA 16229. Request ASTM L-33-1 Die.

<sup>12</sup> The sole source of supply of the apparatus known to the committee at this time is Grainger Inc., 120 Beta Drive, Pittsburgh PA 15238.

<sup>13</sup> The sole source of supply for this material known to the committee at this time is Imerys Fused Materials Niagara Falls, Inc., 2000 College Avenue, M.P.O. Box 1438, Niagara Falls, NY 14302, USA.

<sup>14</sup> The sole source of supply of the apparatus known to the committee at this time is the American National Standards Institute (ANSI), 25 W. 43rd St., 4th Floor, New York, NY 10036.

<sup>15</sup> The sole source of supply of the apparatus known to the committee at this time is Fisher Scientific, 2000 Park Lane Drive, Pittsburgh, PA 15275.

<sup>16</sup> The sole source of supply of the apparatus known to the committee at this time is Exxon\Mobil Oil Company, Fairfax, VA.



build-up of the test axle. Disassemble all bearings from their mating parts. Maintain pinion and differential case shim packs for axle assembly.

9.2.1.2 *Differential Housing Modification*—Drill and tap the housing to accept the temperature sensor using the test fixture shown in Figs. A1.12 and A1.13. Install the temperature sensor so that the tip of the sensor is  $1 \pm 0.25$  in. (25.4 mm  $\pm$  6.4 mm) from the floor of the differential housing as shown in Fig. A1.4.

9.2.1.3 *Cleaning*—Pressure wash the differential housing and each individual component with solvent (see 7.2) using a round plastic bristle brush. Rinse the differential housing and each individual component with solvent, and dry them with compressed air or nitrogen. Do not use wire brushes or abrasive cleaning pads to clean the differential housing and individual components. Remove all grease and oil used during manufacturer's assembly from bearings and wipe clean lip seals with a dry cloth.

9.2.1.4 *Functional Surface and Cover Plate Preparation*—Abrasive blast the entire differential case, ring, pinion, side gears, differential pinion gears (spider gears), all four thrust washers and the inside surface of the housing cover plate by uniformly abrasive blasting with 80 grit aluminum oxide. Do not abrasive blast the bearings, bearing cups and differential shaft (cross shaft pin). Do not touch any cleaned surface with bare hands as moisture can cause rusting.

(1) After abrasive blasting and pre-test inspection (see 9.2.1.5), pressure wash abrasive blasted parts, all four bearings, and bearing cups with solvent and a round plastic bristle brush (pressure not to exceed 30 psi (207 kPa) (see 6.1.2). After pressure washing, rinse with solvent and dry with filtered compressed air or nitrogen (pressure not to exceed 30 psi (207 kPa) (see 7.2). A Wilkerson filter, model M18-02-CH00<sup>17,7</sup> is required to filter the compressed air or nitrogen. A Wilkerson model MTP-96-6461<sup>17,7</sup> is the required replacement element for the filter assembly. Do not use wire brushes or abrasive-cleaning pads to clean the abrasive blasted parts. Do not spin dry the bearings with the compressed air or nitrogen. Only use blowguns without a safety bypass to air-dry the parts. A Milton model S15<sup>18,7</sup> has been found to be acceptable.

9.2.1.5 *Pre-Test Inspection*—After the parts have been abrasive blasted, and before cleaning and rinsing, carefully inspect the abrasive blasted parts, bearings, and bearing cups for rust or corrosion and damage. If any rated area is found to have rust, re-prepare as described in 9.2.1.4. If defects are found, such as casting flaws and so forth, that might be mistaken for rust at the end of test inspection, add a notation of their pre-test existence to the test report. If any bearing is found to have rust or damage, replace it with a new one that is rust-free. The replaced bearing shall be from the same manufacturer and have the same bearing part number. At the end of test inspection and rating make no allowances for parts rusted before start of test.

<sup>17</sup> The sole source of supply of the apparatus known to the committee at this time is Wilkerson Instrument Company, Inc., 2915 Parkway Street, Lakeland, FL 33811.

<sup>18</sup> The sole source of supply of the apparatus known to the committee at this time is McMaster Carr Supply Company, 200 Aurora Industrial Pkwy, Cleveland, OH 44202.

9.2.1.6 *Test Oil Coating*—Immediately coat all abrasive blasted parts evenly with test oil after they have been cleaned, rinsed, and dried. Immediately coat all four bearings, bearing cups, and differential shaft (cross shaft pin) evenly with test oil after they have been cleaned and rinsed. (Bearings, bearing cups, and differential shaft (cross shaft pin) are not abrasive blasted). Dipping the parts in test oil or pouring the test oil over the parts are acceptable methods. Do not use brushes to coat the parts with test oil. Do not touch any test parts with bare hands; fingerprints can cause rusting.

9.2.1.7 Lightly coat all bolts with test oil prior to assembly of test axle.

9.2.1.8 Clean, rinse, dry, and coat all parts with test oil within 2 h after abrasive blasting.

#### 9.2.2 *Assembly of Test Unit:*

9.2.2.1 *Drive Pinion Shaft Installation*—Assemble the drive pinion shaft with its bearings and install it in the housing following the guidelines in 9.2.2. Dana Bulletin No. 5304-2 may be used for additional information, however in all cases the L-33-1 procedure supersedes all information in this bulletin.

(1) Install pinion bearing races into the differential housing. Use care to place the appropriate shims and oil slinger under the rear-bearing race.

(2) Install the rear pinion bearing onto the pinion shaft.

(3) Place the front pinion bearing and oil slinger into the housing and then install the pinion front seal into the housing. Note that the front seal might be damaged during disassembly and may need to be replaced.

(4) Install the pinion shaft, with appropriate bearing preload shims, into the differential housing. The front bearing may need to be tapped into place using a small punch. Install the pinion yoke washer and nut. Torque pinion-nut to 160 to 200 lbf-ft (217 N·m to 271 N·m). This will achieve the compression on the components to eliminate any shaft leakage. Unload the pinion bearings by tapping the pinion with a hammer and punch on the yoke side and gear side. This should completely seat the bearings and races.

(5) Determine the pinion-turning torque. Pinion turning torque is the primary control of the final break and turn results. Set the pinion turning torque to 3 to 10 lbf-in (0.34 N·m to 1.13 N·m).

(6) If necessary, adjust the pinion preload shim pack by removing the pinion nut and tapping the pinion out of the housing. Shims can be used in various combinations to achieve the proper preload. Shim thickness is limited to 0.003, 0.005, 0.010, and 0.030 in. ((0.076, 0.013, 0.025, and 0.726) mm). Add or remove shims to adjust the turning torques. Use caution, shims may remain on the bearing or in the bearing bore.

(7) Repeat item 4 of 9.2.2.1 to assemble pinion.

(8) Record the final pinion break and turning torque on the appropriate test report form.

9.2.2.2 *Differential Case Installation*—Assemble the differential pinion, side gears, shafts and thrust washers, shims, and bearings. Install the differential case assembly and bearing caps in the differential housing. Torque the differential housing bearing caps to 35 to 50 lbf-ft (48 N·m to 68 N·m). Measure

break and turning torque; turn torque shall be 7 to 13 lbf-in. (0.8 N·m to 1.5 N·m) and break torque shall be 8 to 18 lbf-in. (0.9 N·m to 2.0 N·m).

(1) Adjust the final turning torque by removing the differential case and side bearing, adding or removing shims, and then reassemble to obtain final preload.

(2) Repeat item 1 of 9.2.2.2 until the appropriate final turning torque is reached.

(3) Record final break and turning torque on the appropriate test report form.

(4) After completion of the test axle build and before the cover plate installation, place the test axle in a vertical position with the yoke in the upward position. Place the cover in a vertical position. Allow the assembled test axle and cover plate to drain for a minimum of 10 min.

9.2.2.3 *Test Oil Addition*—Charge  $40 \pm 1$  oz (1.20 L  $\pm$  0.03 L) of test oil to the test unit.

9.2.2.4 *Cover Plate, Seals, Temperature Probe Installation*—Install the cover plate with a new TFE fluorocarbon gasket, pre-wetted with the test oil on both sides (see 6.2.4). Use a new TFE fluorocarbon cover plate gasket for every test. Torque the cover plate bolts to 20 to 25 lbf-ft (27 N·m to 34 N·m). Insert the two axle tube opening seals shown in Fig. A1.2 until they touch the differential case bearings, then pull back approximately  $\frac{1}{8}$  in. (3.2 mm). Tighten the seals and install the temperature probe using TFE fluorocarbon tape as shown in Fig. A1.4, Fig. A1.12, and Fig. A1.13. Install the NPT stainless steel 90° street ell and stainless steel full port valve.

## 10. Calibration

### 10.1 Storage Box Calibration:

10.1.1 Reference oils for stand calibration are available from the ASTM TMC.<sup>19</sup> Laboratories wishing to calibrate storage boxes using these oils shall participate in the referencing and storage box calibration program administered for this test by the TMC.

10.1.2 In order to ensure that uniform results are being obtained in the test, complete calibration of storage boxes by testing reference oil samples supplied by the TMC when calibrating or recalibrating. Reference oil performance and test operations are currently monitored by the TMC. Statistics for reference tests are published periodically by the TMC and provide acceptance ranges for the various oils. Contact the TMC for the most current values to evaluate referencing status.

10.1.2.1 *New Storage Box Calibration*—For a new storage box, complete reference tests as prescribed by the TMC, giving results within the established limits for the reference oils. Inspection of the new storage box for compliance with this test method by the TMC is also required.

10.1.2.2 *In-Service Stand Calibration*—For a previously referenced storage box, conduct reference tests giving results within the established limits for those oils at the frequency specified by the TMC. Test oils for this purpose are distributed as blind coded samples by the TMC when a request for

calibration is received. Report all test starts and test data using reference oils to the TMC.

10.1.3 *Reference Test Frequency*—Conduct one reference test every ten test starts or every three months, whichever comes first. This calibration frequency is subject to change as required. Current calibration information is available from the TMC.

10.1.3.1 Reference oil test frequency may be adjusted due to the following reasons:

(1) *Procedural Deviations*—On occasions when a laboratory becomes aware of a significant deviation from the test method, such as might arise during an in-house review or a TMC inspection, the laboratory and the TMC shall agree on an appropriate course of action to remedy the deviation. This action may include the shortening of existing reference oil calibration periods.

(2) *Parts and Fuel Shortages*—Under special circumstances, such as industry-wide parts or fuel shortages, the surveillance panel may direct the TMC to extend the time intervals between reference oil tests. These extensions shall not exceed one regular calibration period.

(3) *Reference Oil Test Data Flow*—To ensure continuous severity and precision monitoring, calibration tests are conducted periodically throughout the year. There may be occasions when laboratories conduct a large portion of calibration tests in a short period of time. This could result in an unacceptably large time frame when very few calibration tests are conducted. The TMC can shorten or extend calibration periods as needed to provide a consistent flow of reference oil test data. Adjustments to calibration periods are made such that laboratories incur no net loss (or gain) in calibration status.

(4) *Special Use of the Reference Oil Calibration System*—The surveillance panel has the option to use the reference oil system to evaluate changes that have potential impact on test severity and precision. This option is only taken when a program of donated tests is not feasible. The surveillance panel and the TMC shall develop a detailed plan for the test program. This plan requires all reference oil tests in the program to be completed as close to the same time as possible, so that no laboratory/stand calibration is left in an excessively long pending status. In order to maintain the integrity of the reference oil monitoring system, each reference oil test is conducted so as to be interpretable for stand calibration. To facilitate the required test scheduling, the surveillance panel may direct the TMC to lengthen and shorten reference oil calibration periods within laboratories such that the laboratories incur no net loss (or gain) in calibration status.

10.1.4 *Donated Reference Oil Test Programs*—The Surveillance Panel is charged with maintaining effective reference oil test severity and precision monitoring. During times of new parts introductions, new or re-blended reference oil additions, and procedural revisions, it may be necessary to evaluate the possible effects on severity and precision levels. The surveillance panel may choose to conduct a program of donated reference oil tests in those laboratories participating in the monitoring system, in order to quantify the effect of a particular change on severity and precision. Typically, the surveillance panel requests its panel members to volunteer enough reference

<sup>19</sup> ASTM Test Monitoring Center, 6555 Penn Avenue, Pittsburgh, PA 15206.

oil test results to create a robust data set. Broad laboratory participation is needed to provide a representative sampling of the industry. To ensure the quality of the data obtained, donated tests are conducted on calibrated test stands. The surveillance panel shall arrange an appropriate number of donated tests and ensure completion of the test program in a timely manner.

10.1.5 All tests are consecutively numbered on a storage box basis. Each storage box has its own unique, permanent identifier. Every test start shall receive a sequential test run number designated before testing begins. All test starts, including aborted starts and operationally invalid tests, shall retain their test run number.

10.1.6 Consider as non-interpretable any non-reference oil test that has not been run in a calibrated test stand or not conducted on approved hardware, or both. Indicate on the cover page of the test report that the test is non-interpretable and that it has not been conducted in a valid manner in accordance with this test method.

### 10.2 Instrumentation Calibration:

10.2.1 *Drive Speed*—Calibrate the drive speed measuring system every six months or 20 tests, whichever occurs first, against a known standard, traceable to NIST.<sup>20</sup>

10.2.2 *Temperature*—Calibrate the temperature controller systems (storage box and motoring) every six months or 20 tests, whichever occurs first, against a known standard, traceable to NIST.

10.2.3 *Pressure Relief System*—Calibrate the pressure relief system every six months or 20 tests, whichever occurs first, using the following process:

10.2.3.1 From the bottom of the dip tube, measure  $27.75 \pm 0.125$  in. ( $704.9 \text{ mm} \pm 3.18 \text{ mm}$ ) and mark this distance on the dip tube.

10.2.3.2 Apply 1 psi (6.9 kPa) to the dip tube.

10.2.3.3 Fill the water column reservoir with specified test water, (see 7.1), until 1 psi (6.9 kPa) is displaced.

10.2.3.4 Release the pressure in the dip tube, and mark the static water level on the dip tube.

10.2.3.5 Apply air pressure to the dip tube until air begins to bubble from the tube to verify calibration. Air pressure shall be  $1 \pm 0.1$  psi ( $6.9 \text{ kPa} \pm 0.7 \text{ kPa}$ ).

## 11. Test Procedure

### 11.1 Pre-Test, Start, and Motoring Phase:

11.1.1 *Installation of Test Unit*—Install the assembled test unit on the motoring rig. Connect the driveshaft and temperature probe. Install the cooling fan and heat lamp pair as shown in Fig. A1.3.

11.1.2 Adjust the temperature controller to maintain  $180 \pm 1^\circ\text{F}$  ( $83 \text{ }^\circ\text{C} \pm 0.6 \text{ }^\circ\text{C}$ ).

11.1.3 Start the driving motor and immediately accelerate the motor to  $(2500 \pm 25)$  r/min. Record the time and the initial oil temperature at the time of the driving motor start up.

11.1.4 Do not exceed 8 h between the beginnings of the abrasive blasting of axle parts to the start of the motoring phase of the test.

11.1.5 Add  $1.00 \pm 0.02$  oz ( $29.6 \text{ mL} \pm 0.6 \text{ mL}$ ) of specified test water with a syringe to the test unit through the full port valve within 5 min after starting the drive motor. Connect the pressure relief system.

11.1.6 Monitor oil temperature and when the oil temperature reaches  $180 \pm 1^\circ\text{F}$  ( $83 \text{ }^\circ\text{C} \pm 0.6 \text{ }^\circ\text{C}$ ), close full port ball valve, disconnect the pressure relief system, and plug the downstream side of valve. This prevents escape of any additional water vapor. Measure and record drive pinion r/min and oil temperature, and report the time at the beginning of motoring phase. Allow a 1 h maximum warm up time for the oil to reach operating temperature of  $180 \pm 1^\circ\text{F}$  ( $83 \text{ }^\circ\text{C} \pm 0.6 \text{ }^\circ\text{C}$ ).

11.1.6.1 Occasionally, a small amount of the test oil and water emulsion will foam up from the axle housing into the accumulator during warm-up. Make every effort to allow the test oil and water emulsion to return to the test axle. Stop the motoring and heating of the test unit in an attempt to return the test oil and emulsion to the test axle. There may be occasions when the test oil and water emulsion will not completely drain back into the carrier as the unit reaches operating temperature. Use caution not to exceed the 1 h maximum warm-up time. Report the number of shutdowns and the estimated amount of test oil and water emulsion that did not return to the carrier in the comment section of the test report.

11.1.7 Motor the test unit for  $4.0 \pm 0.1$  h at  $180 \pm 1^\circ\text{F}$  ( $83 \text{ }^\circ\text{C} \pm 0.6 \text{ }^\circ\text{C}$ ) and  $(2500 \pm 25)$  r/min.

11.1.8 At the end of the motoring phase, measure, and record drive pinion r/min and report the time. Stop the driving motor, turn off the heat lamps and cooling fan.

### 11.2 Transition Phase:

11.2.1 Move the test unit to the storage box within 30 min of the end of the motoring phase. See Fig. A1.6 for physical position. Set the controller at  $125 \pm 1^\circ\text{F}$  ( $52 \text{ }^\circ\text{C} \pm 0.6 \text{ }^\circ\text{C}$ ). Position the axle such that the axle tube openings and the pinion shaft are on a horizontal plane.

11.2.2 Switch on the internal fan. Activate the control system to maintain a test oil temperature of  $125 \pm 1^\circ\text{F}$  ( $52 \text{ }^\circ\text{C} \pm 0.6 \text{ }^\circ\text{C}$ ). The maximum allowable time for the test oil to reach operating temperature of  $125 \pm 1^\circ\text{F}$  ( $52 \text{ }^\circ\text{C} \pm 0.6 \text{ }^\circ\text{C}$ ) from the end of the motoring phase of the test as stated in 11.1.8 is  $1\frac{1}{2}$  h.

### 11.3 Storage Phase:

11.3.1 Record the time of the first occurrence of the test oil temperature reaching  $125 \pm 1^\circ\text{F}$  ( $52 \text{ }^\circ\text{C} \pm 0.6 \text{ }^\circ\text{C}$ ). This is the start of the storage phase.

11.3.2 Continue the storage phase for a total of  $(162 \pm 0.2)$  h.

11.3.3 At the end of the storage phase, record the time, then switch off the storage box-heating unit and circulating fan. The end of the storage phase is the end of the test.

### 11.4 Post Test Procedure:

11.4.1 Immediately remove the test unit from the storage box. Disconnect the temperature sensor. Drain and discard the used test oil. Completely disassemble the test axle within 1 h after the test complete as stated in 11.3.3.

<sup>20</sup> National Institute of Standards and Technology (formerly National Bureau of Standards), Gaithersburg, MD 20899.



11.4.2 Lightly pressure wash all parts with a solvent (see 7.2) to remove used test oil.

11.4.3 Coat test parts in Mobil Arma 245<sup>16,7</sup> prior to final rating.

11.4.4 Clean and coat all parts in Mobil Arma 245<sup>16,7</sup> within 1 h after disassembling the test axle.

11.4.5 If the rating is not to be conducted within 24 h of the end of the test, the coated test parts shall either be stored submerged in the preservative oil, or stored as is in airtight, closed containers. Wrapping the test parts in NOX-RUST paper<sup>21,7</sup> for long-term storage has also been found to be acceptable.

NOTE 2—To preserve test parts in storage or for shipment after completion of all rating and optional documentation photographs, the rust preventative Mobil Arma 245 has been found to be effective in preventing new rust buildup in post-test ambient storage conditions.

## 12. Determination of Test Results

12.1 Conduct parts rating within 14 days from the end of test, under lighting conditions described in ASTM Distress Rating Manual 21.<sup>9</sup> Rate parts in accordance to ASTM Distress Rating Manual 21 and Annex A4. The rating procedure described in Annex A4 supersedes that found in ASTM Distress Rating Manual 21 where applicable. Deposits on rated items will fall under one of two categories: (1) Rust or corrosion; (2) Stain and sludge or other.

12.2 Rust or corrosion deposits will be assigned one of the following integer values: 10, 9, 8, 5, or 0, using these definitions:

None	– 10
Trace	– 9 – not more than six spots, each less than 1 mm in diameter
Light	– 8 – 7 or more spots, each less than 1 mm in diameter or, one or more spots greater or equal to 1 mm in diameter with a combined area of all the spots no greater than 1 % of the total rated component surface
Moderate	– 5 – in excess of above and up to 5 % of considered surface
Severe	– 0 – covering more than 5 % of considered surface

12.3 The areas in Table 1 will be rated as described above.

TABLE 1 Area Number and Rated Surfaces

Area Number	Description
1	differential case pinion spherical machined thrust surfaces
2	differential case side gear thrust surface and hub I.D.
3	differential gears (side gears) thrust surface and hub O.D.
4	axle housing cover plate without the plug
5	ring gear (Drive gear) tooth surfaces
6	drive pinion tooth surfaces
7	drive pinion roller surfaces
8	drive pinion cup (total raceway length)
9	differential case roller surfaces
10	differential case cup (total raceway length)

12.4 By filling in values on the rating sheet and then applying the appropriate weighting values shown in Annex A6, a final deposit merit value is obtained. Note the presence, location, and amount of additional deposits, such as stain and

<sup>21</sup> The sole source of supply of the apparatus known to the committee at this time is Dauber VCI, Inc., 1333 Burr Ridge Parkway, Suite 200, Burr Ridge, IL 60527.

TABLE 2 Test Precision

Variable, merits	Intermediate Precision		Reproducibility	
	S <sub>i,p</sub> <sup>A</sup>	i.p. <sup>B</sup>	S <sub>R</sub> <sup>A</sup>	R <sup>B</sup>
Rust <sup>C</sup>	0.25	0.70	0.25	0.70

<sup>A</sup> S = standard deviations.

<sup>B</sup> This value is obtained by multiplying the standard deviation by 2.8.

<sup>C</sup> These statistics are based on results obtained on TMC Reference Oil 151-3 from June 24, 2002 to Oct. 1, 2003.

sludge, or other, in the Remarks section on the rating sheet. Also note rust in non-rated areas in the Remarks section.

12.5 For a valid rating, rate the test by an individual who has participated in an ASTM sponsored, high volume gear rater calibration workshop within the previous 12 months.

12.6 *Test Validity*—The test is determined to be operationally valid if the percent deviation of the critical operating parameters and number of downtimes are within the limits specified and defined in Annex A2.

12.7 *Severity Adjustment*—Calculate severity adjustments (SA) for results of non-reference gear oil tests. Use the control chart technique, referenced in Annex A5, for determining the laboratory bias for rust or corrosion deposits. Enter the adjustments on the appropriate test form.

## 13. Final Test Report

13.1 For reference oil tests, the standardized report set and data dictionary for reporting test results and for summarizing the operational data are required.

13.2 Report all items using the current report format, which is available from the TMC.

## 14. Precision and Bias

### 14.1 Precision:

14.1.1 Test precision is established on the basis of operationally valid reference oil test results monitored by the TMC. Test precision shown in Table 2 is considered current as of Feb. 16, 2005. Research Report RR:D02-1554<sup>22</sup> contains industry data developed prior to establishment of this test method.

14.1.2 *Intermediate Precision Conditions*—Conditions where test results are obtained with the same test method using the same oil, with changing conditions such as operators, measuring equipment, test stands, test engines and time.

NOTE 3—Intermediate precision is the appropriate term for this method rather than repeatability, which defines more rigorous within-laboratory conditions.

14.1.3 *Intermediate Precision Limit (i.p.)*—The difference between two results obtained under intermediate precision conditions that would in the long run, in the normal and correct conduct of the test method, exceed the values shown in Table 2 in one case in twenty.

14.1.4 *Reproducibility Conditions*—Conditions where test results are obtained with the same test method using the same test oil in different laboratories with different operators using different equipment.

<sup>22</sup> Supporting data have been filed at ASTM International Headquarters and may be obtained by requesting Research Report RR:D02-1554.

14.1.5 *Reproducibility Limit (R)*—The difference between two results obtained under reproducibility conditions that would, in the long run, in the normal and correct conduct of the test method, exceed the values in **Table 2** only in one case in twenty.

14.2 *Bias*—Bias will be determined by applying an accepted statistical technique to reference oil test results, and when a significant bias is determined, a severity adjustment will be permitted for non-reference oil test results.

**15. Keywords**

15.1 corrosion; final drive axle; gear failure; gears; lubricants; L-33-1; moisture; rust

**ANNEXES**

**(Mandatory Information)**

**A1. SYSTEM SCHEMATICS**

A1.1 The following schematics (**Figs. A1.1-A1.15**) are shown to assist the users of this test method.

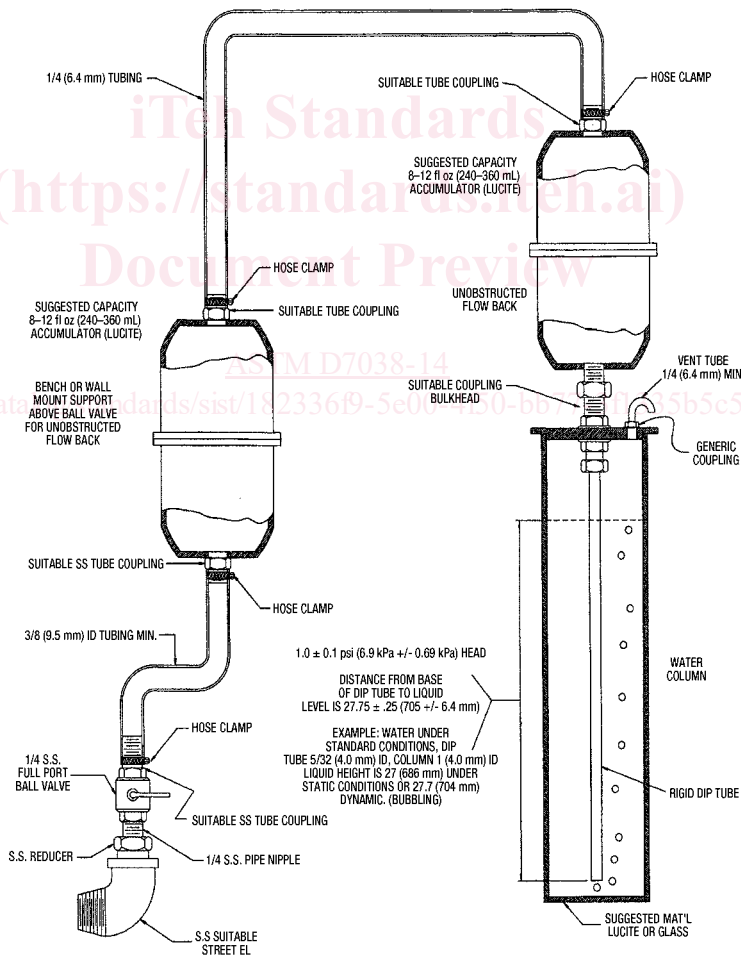

NOTE 1—Dimensions are in inch-pound units, with SI units in parentheses.

**FIG. A1.1 Pressure Control System**



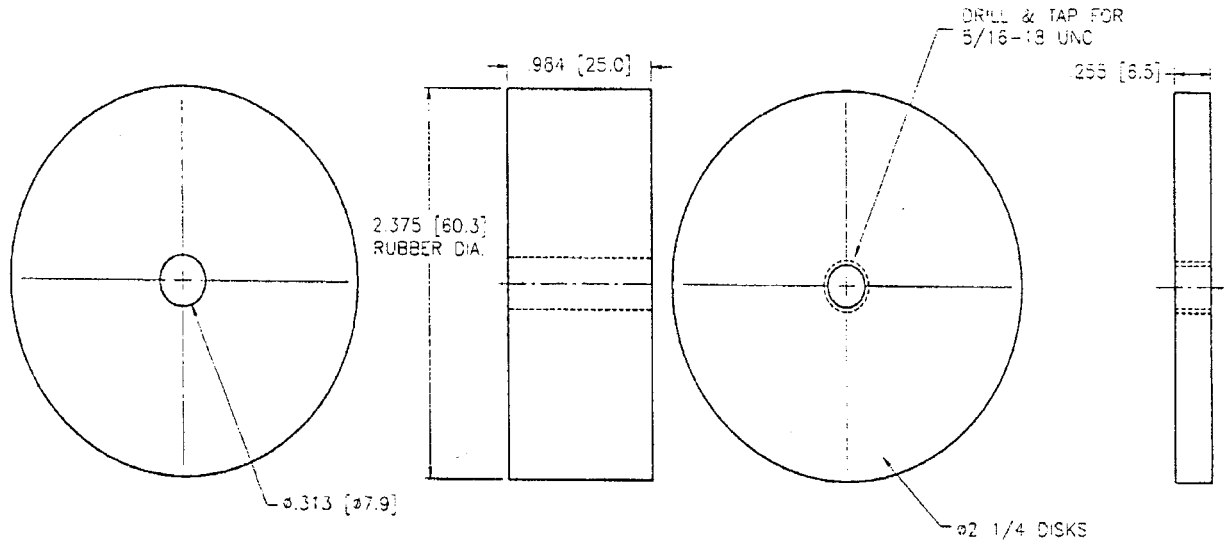

SUGGESTED SEAL MATERIAL - NEOPRENE

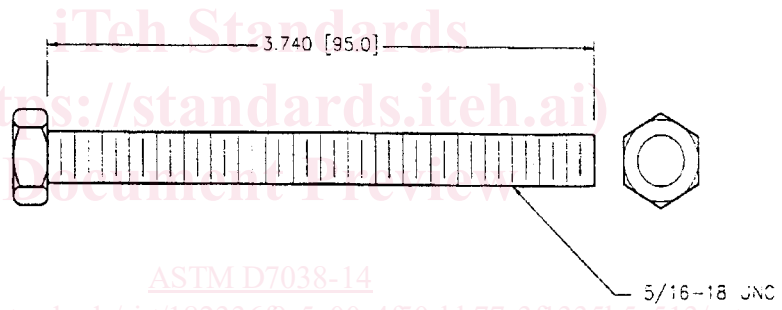

ASTM D7038-14  
BOLT AND WASHERS - STAINLESS STEEL

NOTE 1—Dimensions are in inches (millimetres).

FIG. A1.2 Axle Seals

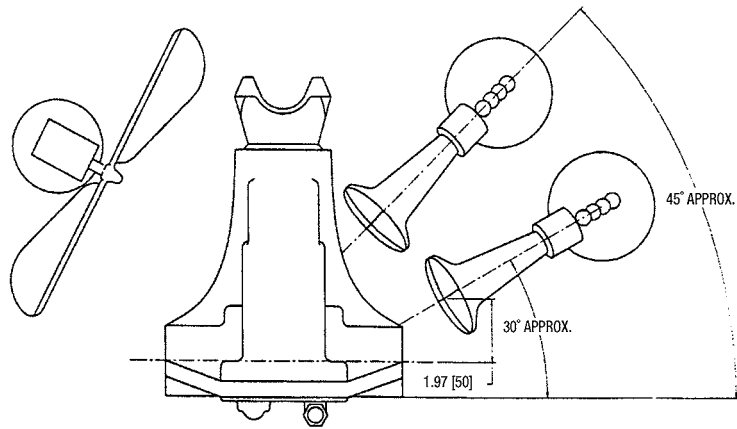

PLACE HEAT LAMPS AND FAN AS SHOWN.  
HEAT LAMPS TO BE APPROXIMATELY 50 mm  
FROM HOUSING. FAN IS TO BE APPROXIMATELY  
150 mm FROM HOUSING.

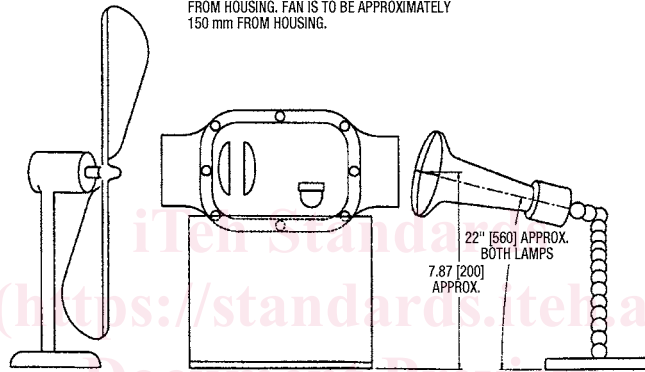

NOTE 1—Dimensions are in inches (millimetres).

**FIG. A1.3 Heat Lamp And Fan Arrangement**

ASTM D7038-14

<https://standards.iteh.ai/catalog/standards/sist/18233619-5e00-4f50-bb77-3f1335b5c513/astm-d7038-14>