



Designation: **A255 – 10 A255 – 10 (Reapproved 2014)**

Standard Test Methods for Determining Hardenability of Steel¹

This standard is issued under the fixed designation A255; the number immediately following the designation indicates the year of original adoption or, in the case of revision, the year of last revision. A number in parentheses indicates the year of last reapproval. A superscript epsilon (ϵ) indicates an editorial change since the last revision or reapproval.

This standard has been approved for use by agencies of the U.S. Department of Defense.

1. Scope

1.1 These test methods cover the identification and description of test methods for determining the hardenability of steels. The two test methods include the quantitative end-quench or Jominy Test and a method for calculating the hardenability of steel from the chemical composition based on the original work by M. A. Grossman.

1.2 The selection of the test method to be used for determining the hardenability of a given steel shall be agreed upon between the supplier and user. The Certified Material Test Report shall state the method of hardenability determination.

1.3 The calculation method described in these test methods is applicable only to the range of chemical compositions that follow:

Element	Range, %
Carbon	0.10–0.70
Manganese	0.50–1.65
Silicon	0.15–0.60
Nickel	1.50 max
Chromium	1.35 max
Molybdenum	0.55 max
Copper	0.35 max
Vanadium	0.20 max

1.4 Hardenability is a measure of the depth to which steel will harden when quenched from its austenitizing temperature (Table 1). It is measured quantitatively, usually by noting the extent or depth of hardening of a standard size and shape of test specimen in a standardized quench. In the end-quench test the depth of hardening is the distance along the specimen from the quenched end which correlates to a given hardness level.

1.5 The values stated in inch-pound units are to be regarded as the standard. The values given in parentheses are for information only—mathematical conversions to SI units that are provided for information only and are not considered standard.

1.6 *This standard does not purport to address all of the safety concerns, if any, associated with its use. It is the responsibility of the user of this standard to establish appropriate safety and health practices and determine the applicability of regulatory limitations prior to use.*

2. Referenced Documents

2.1 *ASTM Standards*:²

[E18 Test Methods for Rockwell Hardness of Metallic Materials](#)

[E112 Test Methods for Determining Average Grain Size](#)

2.2 *ASTM Adjuncts*:

ASTM Hardenability Chart³

¹ These test methods are under the jurisdiction of ASTM Committee A01 on Steel, Stainless Steel and Related Alloys and are the direct responsibility of Subcommittee A01.15 on Bars.

Current edition approved May 1, 2014/Oct. 1, 2014. Published June 2014/October 2014. Originally approved in 1942. Last previous edition approved in 2007/2010 as A255 – 07/A255 – 10. DOI: 10.1520/A0255-10.1520/A0255-10R14.

² For referenced ASTM standards, visit the ASTM website, www.astm.org, or contact ASTM Customer Service at service@astm.org. For *Annual Book of ASTM Standards* volume information, refer to the standard's Document Summary page on the ASTM website.

³ Standard ASTM Hardenability Charts (8½ by 11 in. pads of 50 charts) are available from ASTM International Headquarters. Order Adjunct No. ADJA0255. Original adjunct produced in 1945.

*A Summary of Changes section appears at the end of this standard

TABLE 1 Normalizing and Austenitizing Temperatures^A

Steel Series	Ordered Carbon Content, max, %	Normalizing Temperature, °F (°C)	Austenitizing Temperature, °F (°C)
1000, 1300, 1500, 3100, 4000, 4100	0.25 and under	1700 (925)	1700 (925)
4300, 4400, 4500, 4600, 4700, 5000, 5100, 6100, ^B 8100, 8600, 8700, 8800, 9400, 9700, 9800	0.26 to 0.36, incl	1650 (900)	1600 (870)
2300, 2500, 3300, 4800, 9300	0.37 and over	1600 (870)	1550 (845)
	0.25 and under	1700 (925)	1550 (845)
	0.26 to 0.36, incl	1650 (900)	1500 (815)
	0.37 and over	1600 (870)	1475 (800)
9200	0.50 and over	1650 (900)	1600 (870)

^A A variation of ±10°F (6°C) from the temperatures in this table is permissible.

^B Normalizing and austenitizing temperatures are 50°F (30°C) higher for the 6100 series.

END-QUENCH OR JOMINY TEST

3. Description

3.1 This test method covers the procedure for determining the hardenability of steel by the end-quench or Jominy test. The test consists of water quenching one end of a cylindrical test specimen 1.0 in. in diameter and measuring the hardening response as a function of the distance from the quenched end.

4. Apparatus

4.1 *Support for Test Specimen*—A fixture for supporting the test specimen vertically so that the lower end of the specimen is a distance of 0.5 in. (12.7 mm) above the orifice of the water-quenching device. A satisfactory type of support for the standard 1.0-in. (25.4-mm) specimen is shown in Fig. 1.

NOTE 1—A suitable support for other sizes and shapes of specimens is shown in Fig. X1.1.

4.2 *Water-Quenching Device*—A water-quenching device of suitable capacity to provide a vertical stream of water that can be controlled to a height of 2.5 in. (63.5 mm) when passing through an orifice 0.5 in. (12.7 mm) in diameter. A tank of sufficient capacity to maintain the water temperature requirements of 6.3 with a small pump and control valves will be found satisfactory. The water-supply line shall also be provided with a quick opening valve.

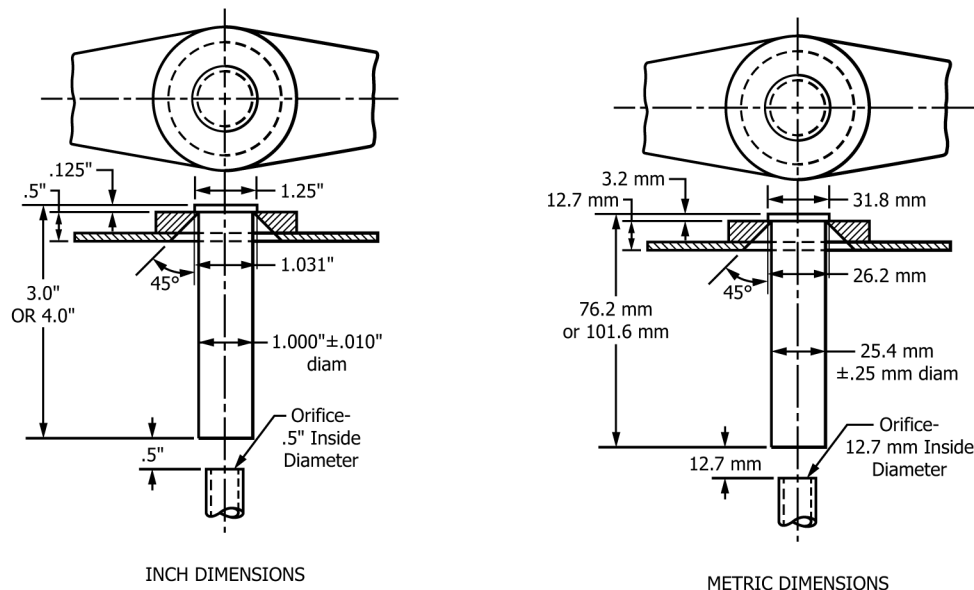

FIG. 1 Test Specimen in Support for Water Quenching

5. Test Specimens

5.1 *Wrought Specimens*—End-quench specimens shall be prepared from rolled or forged stock and shall represent the full cross section of the product. If negotiated between the supplier and the user, the end-quench specimen may be prepared from a given location in a forged or rolled product or from a continuous cast billet. The test specimen shall be 1.0 in. (25.4 mm) in diameter by 4.0 in. (101.6 mm) in length, with means for hanging it in a vertical position for end quenching. Dimensions of the preferred specimen and of an optional specimen (Note 2) are given in Figs. 2 and 3. The specimen shall be machined from a bar previously normalized in accordance with 6.1 and of such size as to permit the removal of all decarburization in machining to 1.0 in. round. The end of the specimen to be water cooled shall have a reasonably smooth finish, preferably produced by grinding. Normalizing may be waived by agreement between the supplier and the user. The previous thermal history of the specimen tested shall always be recorded.

5.2 *Cast Specimens*—A separately cast end-quench specimen may be used for non-boron steels. Cast specimens are not suitable for boron steel grades due to erratic results. A graphite or metal mold may be used to form an overlength specimen 1.0 in. (25.4 mm) in diameter which shall be cut to the standard specimen size. The mold may also be used to form a 1.25-in. (31.8-mm) diameter specimen which shall be machined to the final specimen size. Cast tests need not be normalized.

NOTE 2—Other sizes and shapes of test specimens are described in Appendix X1.

6. Procedure

6.1 *Normalizing*—The wrought product from which the specimen is to be prepared shall be normalized to ensure proper hardening characteristics. The sample shall be held at the temperature listed in Table 1 for 1 h and cooled in air. Tempering of the normalized sample to improve machinability is permitted.

6.2 *Heating*—Place the specimen in a furnace that is at the specified austenitizing temperature (Table 1) and hold at this temperature for 30 min. In production testing slightly longer times up to 35 min may be used without appreciably affecting results. It is important to heat the specimen in such an atmosphere that practically no scaling and a minimum of decarburization takes place. This may be accomplished by heating the specimen in a vertical position in a container with an easily removable cover containing a layer of cast-iron chips with the bottom face of the specimen resting on the chips.

6.2.1 Other methods consist of placing the specimen in an appropriately sized hole in a graphite block or placing the specimen in an upright tube attached to a flat base, both of a heat-resistant metal, with the collar projecting for a tong hold. Place a disk of graphite or carbon, or a layer of carbonaceous material such as charcoal, in the bottom of the tube to prevent scaling.

6.2.2 For a particular fixture and furnace, determine the time required to heat the specimen to the austenitizing temperature by inserting a thermocouple into a hole drilled axially in the top of the specimen. Repeat this procedure periodically, for example once a month, for each combination of fixture and furnace.

6.3 *Quenching*—Adjust the water-quenching device so that the stream of water rises to a free height of 2.5 in. (63.5 mm) above the 0.5-in. (12.7-mm) orifice, without the specimen in position. The support for the specimen shall be dry at the beginning of each test. Then place the heated specimen in the support so that its bottom face is 0.5 in. above the orifice, and turn on the water by means of the quick-opening valve. The time between removal of the specimen from the furnace and the beginning of the quench should not be more than 5 s. Direct the stream of water, at a temperature of 40 to 85°F (5 to 30°C), against the bottom face of the specimen for not less than 10 min. Maintain a condition of still air around the specimen during cooling. If the specimen is not cold when removed from the fixture, immediately quench it in water.

6.4 *Hardness Measurement*—Two flats 180° apart shall be ground to a minimum depth of 0.015 in. (0.38 mm) along the entire length of the bar and Rockwell C hardness measurements made along the length of the bar. Shallower ground depths can affect reproducibility of results, and correlation with cooling rates in quenched bars.

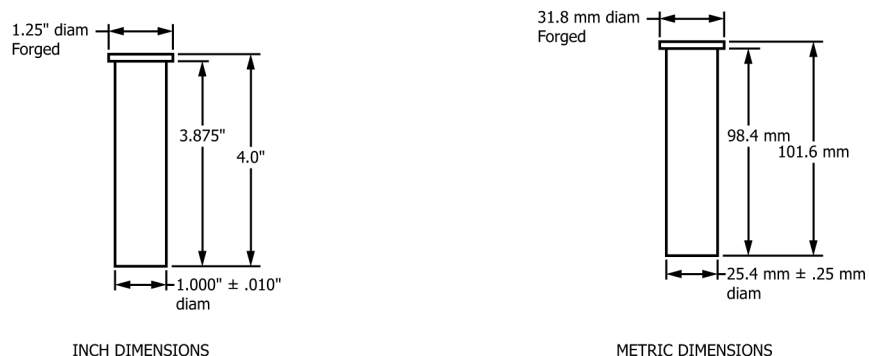

FIG. 2 Preferred Test Specimen

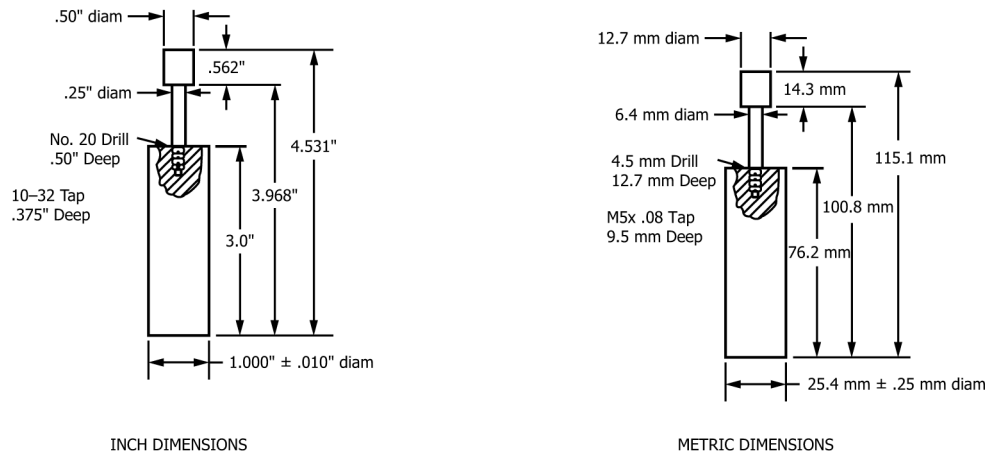

FIG. 3 Optional Test Specimen

6.4.1 The preparation of the two flats must be carried out with considerable care. They should be mutually parallel and the grinding done in such a manner that no change of the quenched structure takes place. Very light cuts with water cooling and a coarse, soft-grinding wheel are recommended to avoid heating the specimen. In order to detect tempering due to grinding, the flat may be etched with one of the following etchant solutions:

NOTE 3—5 % nitric acid (concentrated) and 95 % water by volume.

NOTE 4—50 % hydrochloric acid (concentrated) and 50 % water by volume.

Wash the sample in hot water. Etch in solution No. 1 until black. Wash in hot water. Immerse in solution No. 2 for 3 s and wash in hot water. Dry in air blast.

6.4.1.1 The presence of lighter or darker areas indicates that hardness and structure have been altered in grinding. If such changes caused by grinding are indicated, new flats may be prepared.

6.4.2 When hardness tests are made, the test specimen rests on one of its flats on an anvil firmly attached to the hardness machine. It is important that no vertical movement be allowed when the major load is applied. The anvil must be constructed to move the test specimen past the penetrator in accurate steps of $\frac{1}{16}$ in. (1.5 mm). Resting the specimen in a V-block is not permitted.

6.4.2.1 The Rockwell tester should periodically be checked against standard test blocks. It is recommended that a test block be interposed between the specimen and the indenter to check the seating of the indenter and the specimen simultaneously. For general statements regarding the use of test blocks and surface conditions, reference should be made to 4.7 and 5.2, respectively, of Test Methods E18.

6.4.3 Exercise care in registering the point of the indenter in relationship to the quenched end of the specimen as well as providing for accurate spacing between indentations. A low-power measuring microscope is suitable for use in determining the distance from the quenched end to the center of the first impression and in checking the distance from center to center of the succeeding impressions. It has been found that with reasonable operating care and a well-built fixture, it is practical to locate the center of the first impression 0.0625 ± 0.004 in. (1.5 ± 0.10 mm) from the quenched end. The variations between spacings should be even smaller. Obviously, it is more important to position the indenter accurately when testing low-hardenability steels than when testing high-hardenability steels. The positioning of the indenter should be checked with sufficient frequency to provide assurance that accuracy requirements are being met. In cases of lack of reproducibility or of differences between laboratories, indenter spacing should be measured immediately.

6.4.4 Readings shall be taken in steps of $\frac{1}{16}$ in. (1.6 mm) for the first 16 sixteenths (25.4 mm), then 18, 20, 22, 24, 28, and 32 sixteenths of an inch. Values below 20 HRC are not recorded because such values are not accurate. When a flat on which readings have been made is used as a base, the burrs around the indentation shall be removed by grinding unless a fixture is used which has been relieved to accommodate the irregularities due to the indentations.

6.4.4.1 Hardness readings should preferably be made on two flats 180° apart. Testing on two flats will assist in the detection of errors in specimen preparation and hardness measurement. If the two probes on opposite sides differ by more than 4 HRC points at any one position, the test should be repeated on new flats, 90° from the first two flats. If the retest also has greater than 4 HRC points spread, a new specimen should be tested.

6.4.4.2 For reporting purposes, hardness readings should be recorded to the nearest integer, with 0.5 HRC values rounded to the next higher integer.

7. Plotting Test Results

7.1 Test results should be plotted on a standard hardenability chart prepared for this purpose, in which the ordinates represent HRC values and the abscissae represent the distance from the quenched end of the specimen at which the hardness determinations

were made. When hardness readings are taken on two or more flats, the values at the same distance should be averaged and that value used for plotting. A facsimile of the standard ASTM hardenability chart³ on which typical hardenability curves have been plotted is shown in Fig. 4.

8. Index of Hardenability

8.1 The hardenability of a steel can be designated by a specific HRC hardness value or HRC hardness value range at a given Jominy (“J”) distance. Examples of this method are J ¼ in. (6.4 mm) = 47 HRC min, J ⅞ in. (11.1 mm) = 50 HRC max, and J ⅝ in. (7.9 mm) = 38–49 HRC.

9. Report

- 9.1 Report the following information that may be recorded on the ASTM hardenability chart:
 - 9.1.1 Previous thermal history of the specimen tested, including the temperature of normalizing and austenitizing,
 - 9.1.2 Chemical Composition,
 - 9.1.3 ASTM grain size (McQuaid-Ehn) as determined by Test Methods E112, unless otherwise indicated, and
 - 9.1.4 A prominent notation on the standard hardenability chart if any of the test specimens listed in Appendix X1 are used.

CALCULATION OF HARDENABILITY

10. Introduction

10.1 This method of Jominy Hardenability calculation from the chemical ideal diameter (DI) on a steel is based on the original work of M. A. Grossman and provides increased accuracy by refinement of the carbon multiplying factors and the correlation of a boron factor (B.F.) with carbon and alloy content. These refinements were based on analysis of thousands of heats of boron and

A. S. T. M. END QUENCH TEST FOR HARDENABILITY OF STEEL (A 255-48 T) DATE _____
 LABORATORY _____
 TYPE SPECIMEN _____
 TEST NO. _____

TYPE	HEAT NO.	GRAIN SIZE	C	Mn	P	S	Si	Ni	Cr	Mo		NORM. TEMP. °F.	QUENCH TEMP. °F.
8740	19297	8-7	.44	.89	.019	.016	.27	.58	.50	.25		±600	1550
8620	621271	7-8	.19	.80	.015	.015	.23	.46	.52	.22		1700	1700

REMARKS:

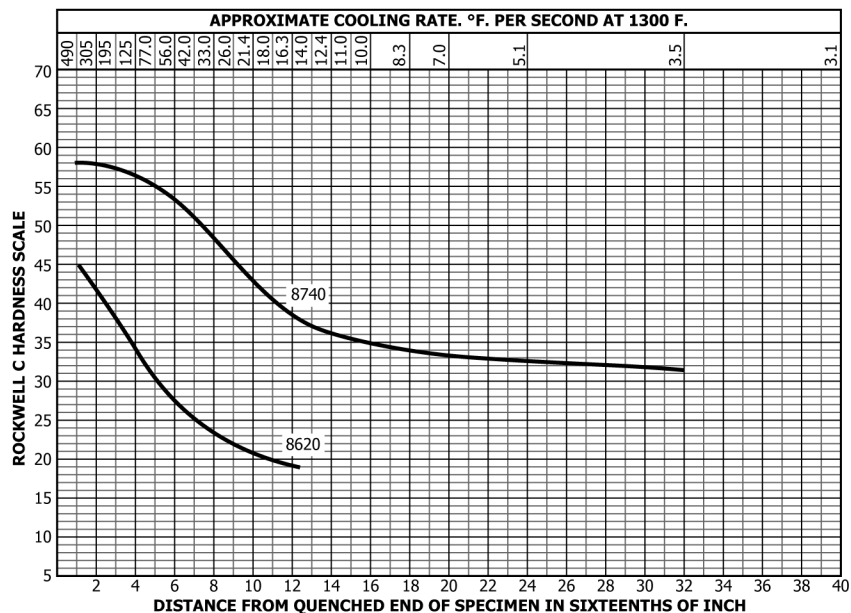

FIG. 4 Facsimile of Standard ASTM Hardenability Chart, Showing Typical Hardenability Curves [Chart Size: 8½ by 11 in. (216 by 279 mm)]

non-boron 1500, 4100, 5000, and 8600 series steels encompassing a range of compositions as follows and a range of DI as contained in **Tables 2-5**. The accuracy of this test method and the techniques used to develop it have been documented. For comparison of this test method to others, or for steel compositions outside the mentioned grades, the user should refer to other articles concerned with calculating hardenability.

Element	Range, %
Carbon	0.10–0.70
Manganese	0.50–1.65
Silicon	0.15–0.60
Nickel	1.50 max
Chromium	1.35 max
Molybdenum	0.55 max
Copper	0.35 max
Vanadium	0.20 max

10.1.1 Calculated DI and Jominy hardenability curves are valid only within the chemical ranges stated above. However, to facilitate melting process control for higher alloy steels, Hardenability Multiplying Factors have been included for calculating the DI within the following chemical composition ranges:

Element	Range, %
Carbon	0.01–0.90
Manganese	0.01–1.95
Silicon	0.01–2.00
Nickel	0.01–3.50
Chromium	0.01–2.50
Molybdenum	0.01–0.55
Copper	0.01–0.55
Vanadium	0.01–0.20
Zirconium	0.01–0.25

10.2 **Tables 2-18** are to be used to calculate hardenability from the chemical ideal diameter for the grades shown in **10.1**. Hardenability results are to be reported for the first 10 sixteenth (16 mm), the 12, 14, 16, 18, 20, 24, 28, and 32 sixteenths of an inch.

NOTE 5—The reporting of hardenability using the calculated method differs from the procedure as shown in **6.4.4**.

10.3 *DI Calculation for Non-Boron Steels*—This calculation relies on a series of hardenability factors (**Table 6**) for each alloying element in the composition which, when multiplied together, gives a DI value. (For simplicity, only multiplying factors for DI in inch-pound units are given. For DI in millimetres, use the metric value table.) The effects of phosphorous and sulfur are not considered since they tend to cancel one another. A No. 7 austenitic grain size is assumed since most steels with hardenability control are melted to a fine-grain practice where experience has demonstrated that a high percentage of heats conform to this grain size. An example DI calculation is given as follows for an SAE 4118 modified steel:

Element	%	Multiplying Factor
Carbon	0.22	0.119
Manganese	0.80	3.667
Silicon	0.18	1.126
Nickel	0.10	1.036
Chromium	0.43	1.929
Molybdenum	0.25	1.75
Copper	0.10	1.04
Vanadium	0.05	1.09

where:

$$DI = 0.119 \times 3.667 \times 1.126 \times 1.036 \times 1.929 \times 1.75 \times 1.04 \times 1.09 = 1.95 \text{ in.}$$

10.4 *DI Calculation for Boron Steels*—With an effective steel making process, the boron factor (signifying the contribution for boron to increased hardenability) is an inverse function of the carbon and alloy content. The higher the carbon or alloy content, or both, the lower the boron factor.

10.4.1 The actual boron factor is expressed by the following relationship:

$$B.F. = \frac{\text{measured DI (from Jominy data and carbon content)}}{\text{calculated DI (from composition excluding boron)}} \quad (1)$$

10.4.2 An example of actual boron factor determination is given as follows for an SAE 15B30 modified steel:

Composition, %	C	Mn	Si	Ni	Cr	Mo	Cu	B	Calculated DI (boron excluded)
	0.29	1.25	0.20	0.13	0.07	0.03	0.24	0.0015	1.35 in.

	End-Quench Test Results, in.						
"J" Position (1/8 in.)	1	2	3	4	5	6	7
Hardness, HRC	50	50	49	48	47	45	41
"J" Position (1/8 in.)	8	9	10	12	14	16	
Hardness, HRC	38	33	28	25	22	20	

10.4.3 Using **Table 7**, determine the nearest location on the end-quench curve where hardness corresponding to 50% martensite occurs for the actual carbon content. For the example heat with 0.29 carbon, this hardness is 37 HRC occurring at a "J" distance of 8/16 in. from the quenched end (interpolation required).

10.4.4 From **Table 8** (in.), a "J" distance of 8/16 in. equates to a measured DI of 2.97 in. (interpolation required).

$$\text{Boron Factor} = \frac{2.97 \text{ in.}}{1.35 \text{ in.}} = 2.2 \text{ boron factor} \quad (2)$$

10.4.5 *Calculation of DI with Boron (DI_B):*

10.4.5.1 Calculate the DI without boron. For the example in **10.4.4**, this DI is 1.35 in.

10.4.5.2 Calculate the alloy factor (the product of all the multiplying factors from **Table 6** excluding carbon). For the example in **10.4.4**:

$$\text{Alloy Factor} = \frac{\text{Calculated DI (without boron)}}{\text{Carbon multiplying factor}} = \frac{1.35 \text{ in.}}{0.157 \text{ in.}} = 8.6 \quad (3)$$

10.4.5.3 Determine the boron multiplying factor from **Table 10**. For this example with 0.29% carbon and an alloy factor of 8.6, the boron multiplying factor is 2.31 (interpolation required).

10.4.6 Calculate the DI with boron as follows:

where:

$$DI_B = \text{DI (without boron)} \times \text{boron factor}$$

$$DI_B = 1.35 \text{ in.} \times 2.31$$

$$DI_B = 3.12 \text{ in.}$$

10.5 *Hardenability Curves from Composition*—With a predetermined DI (DI_B for boron steel), the end-quench hardenability curve can be computed by the following procedure:

10.5.1 The initial hardness (IH) at the J = 1/16 in. position is a function of carbon content and independent of hardenability and is selected from **Table 7**. For the example non-boron SAE 4118 modified heat containing 0.22 % carbon, the initial hardness is 45 HRC.

10.5.2 The hardness at other positions along the end-quench specimen (termed distance hardness) is determined by dividing the initial hardness by the appropriate factor from **Table 2** (in.) or **Table 3** (mm) for non-boron steels or from **Table 4** (in.) or **Table 5** (mm) for boron steels.

10.6 For the example non-boron heat with an IH = 45 HRC and a calculated DI of 1.95 in., the hardness at the respective end-quench positions can be calculated by dividing 45 by the appropriate dividing factor listed in **Table 2** (in.) for non-boron steels. (For simplicity, the DI should be rounded to the nearest 0.1 in.).

10.7 Distance Dividing Hardness Factors in **Tables 2-5** are calculated from the equations in **Tables 15-18**. Multiplying Factors in **Table 6** are calculated from the equations in **Table 11**. Jominy Distance for 50 % Martensite versus DI in **Tables 8 and 9** are calculated from the equations in **Table 13**. Boron Factor versus % Carbon and Alloy Factor in **Table 10** are calculated from the equations in **Table 14**. Equations representing a least squares polynomial fit of the data contained in **Table 7** is listed in **Table 12**. The use of these equations to plot curves may result in random inflection points due to the characteristics of polynomial equations. These inflections will be minor, however, and should be disregarded.

11. Keywords

11.1 end-quench hardenability; hardenability

TABLE 2 Distance Hardness Dividing Factors for Non-Boron Steels, in.

Ideal Diameter (D), in.	Jominy End-Quench Distance ($\frac{1}{16}$ in.)																
	2	3	4	5	6	7	8	9	10	12	14	16	18	20	24	28	32
1	1.15	1.50	2.14	2.46	2.72	2.81	2.92	3.07	3.22	3.49							
1.1	1.12	1.42	1.99	2.32	2.60	2.70	2.80	2.94	3.07	3.34							
1.2	1.10	1.35	1.85	2.20	2.48	2.59	2.69	2.81	2.94	3.20	3.32	3.44					
1.3	1.08	1.29	1.74	2.09	2.38	2.48	2.58	2.69	2.81	3.07	3.19	3.30	3.53				
1.4	1.07	1.24	1.64	1.99	2.27	2.38	2.47	2.58	2.69	2.95	3.06	3.17	3.37	3.50	3.79		
1.5	1.05	1.19	1.56	1.89	2.18	2.28	2.37	2.47	2.58	2.83	2.94	3.05	3.22	3.35	3.61		
1.6	1.04	1.16	1.49	1.81	2.09	2.19	2.28	2.37	2.47	2.73	2.83	2.94	3.09	3.21	3.45	3.67	3.77
1.7	1.03	1.13	1.43	1.73	2.00	2.10	2.19	2.28	2.38	2.62	2.73	2.83	2.96	3.07	3.30	3.51	3.63
1.8	1.02	1.11	1.37	1.66	1.92	2.02	2.11	2.19	2.29	2.53	2.63	2.73	2.85	2.95	3.17	3.37	3.49
1.9	1.02	1.09	1.33	1.60	1.85	1.94	2.03	2.11	2.20	2.44	2.54	2.64	2.74	2.84	3.04	3.24	3.36
2	1.01	1.08	1.29	1.54	1.78	1.87	1.95	2.03	2.12	2.35	2.45	2.55	2.65	2.74	2.93	3.12	3.24
2.1	1.01	1.07	1.26	1.48	1.72	1.80	1.89	1.96	2.05	2.27	2.37	2.47	2.56	2.65	2.83	3.00	3.13
2.2	1.00	1.07	1.23	1.44	1.65	1.74	1.82	1.90	1.98	2.20	2.30	2.39	2.47	2.56	2.74	2.90	3.03
2.3	1.00	1.06	1.21	1.39	1.60	1.68	1.76	1.83	1.91	2.13	2.22	2.32	2.40	2.48	2.65	2.81	2.93
2.4	1.00	1.06	1.18	1.35	1.55	1.62	1.70	1.77	1.85	2.06	2.16	2.25	2.32	2.41	2.57	2.72	2.84
2.5	1.00	1.05	1.17	1.32	1.50	1.57	1.65	1.72	1.80	2.00	2.09	2.19	2.26	2.34	2.50	2.64	2.76
2.6	1.00	1.05	1.15	1.29	1.45	1.52	1.60	1.67	1.74	1.94	2.03	2.13	2.19	2.27	2.43	2.57	2.68
2.7	1.00	1.04	1.13	1.26	1.41	1.48	1.56	1.62	1.69	1.88	1.97	2.07	2.14	2.21	2.37	2.50	2.61
2.8	1.00	1.04	1.12	1.23	1.37	1.44	1.52	1.58	1.65	1.83	1.92	2.02	2.08	2.16	2.31	2.43	2.54
2.9	1.00	1.03	1.11	1.21	1.34	1.40	1.48	1.54	1.61	1.78	1.87	1.97	2.03	2.10	2.25	2.37	2.48
3	1.00	1.02	1.10	1.19	1.31	1.37	1.44	1.50	1.56	1.73	1.82	1.92	1.98	2.05	2.20	2.31	2.41
3.1	1.00	1.01	1.09	1.17	1.28	1.34	1.41	1.47	1.53	1.68	1.77	1.87	1.94	2.01	2.15	2.26	2.36
3.2	1.00	1.00	1.08	1.15	1.25	1.31	1.38	1.43	1.49	1.64	1.73	1.83	1.89	1.96	2.10	2.21	2.30
3.3	1.00	1.00	1.07	1.13	1.23	1.28	1.35	1.40	1.46	1.60	1.69	1.79	1.85	1.92	2.05	2.16	2.25
3.4	1.00	1.00	1.06	1.12	1.20	1.26	1.32	1.37	1.43	1.56	1.65	1.75	1.81	1.87	2.01	2.11	2.20
3.5	1.00	1.00	1.05	1.10	1.18	1.24	1.30	1.35	1.40	1.53	1.61	1.71	1.77	1.83	1.96	2.07	2.15
3.6	1.00	1.00	1.05	1.09	1.17	1.22	1.28	1.32	1.37	1.49	1.58	1.68	1.73	1.79	1.92	2.02	2.10
3.7	1.00	1.00	1.04	1.08	1.15	1.20	1.26	1.30	1.35	1.46	1.54	1.64	1.70	1.76	1.87	1.98	2.06
3.8	1.00	1.00	1.04	1.07	1.14	1.18	1.24	1.28	1.32	1.43	1.51	1.61	1.66	1.72	1.83	1.94	2.01
3.9	1.00	1.00	1.03	1.06	1.12	1.17	1.22	1.25	1.30	1.40	1.48	1.58	1.63	1.68	1.79	1.90	1.97
4	1.00	1.00	1.02	1.05	1.11	1.15	1.20	1.24	1.28	1.37	1.45	1.55	1.60	1.65	1.75	1.86	1.93
4.1	1.00	1.00	1.01	1.04	1.10	1.14	1.18	1.22	1.26	1.35	1.42	1.52	1.57	1.62	1.71	1.82	1.89
4.2	1.00	1.00	1.00	1.03	1.09	1.13	1.17	1.20	1.24	1.32	1.39	1.49	1.54	1.58	1.68	1.78	1.85
4.3	1.00	1.00	1.00	1.02	1.08	1.12	1.15	1.18	1.22	1.30	1.37	1.46	1.51	1.55	1.64	1.75	1.82
4.4	1.00	1.00	1.00	1.01	1.07	1.10	1.14	1.17	1.21	1.28	1.35	1.44	1.48	1.52	1.60	1.71	1.78
4.5	1.00	1.00	1.00	1.00	1.06	1.09	1.13	1.15	1.19	1.26	1.32	1.41	1.45	1.49	1.57	1.67	1.75
4.6	1.00	1.00	1.00	1.00	1.05	1.08	1.11	1.14	1.18	1.24	1.30	1.39	1.42	1.46	1.54	1.64	1.71
4.7	1.00	1.00	1.00	1.00	1.04	1.07	1.10	1.13	1.16	1.22	1.28	1.36	1.40	1.43	1.50	1.60	1.68
4.8	1.00	1.00	1.00	1.00	1.03	1.06	1.09	1.11	1.15	1.21	1.26	1.34	1.37	1.40	1.47	1.57	1.65
4.9	1.00	1.00	1.00	1.00	1.02	1.05	1.08	1.10	1.13	1.19	1.24	1.32	1.35	1.37	1.44	1.54	1.62
5	1.00	1.00	1.00	1.00	1.01	1.04	1.07	1.09	1.12	1.18	1.23	1.30	1.32	1.35	1.41	1.51	1.59
5.1	1.00	1.00	1.00	1.00	1.00	1.03	1.06	1.08	1.11	1.17	1.21	1.28	1.30	1.32	1.39	1.48	1.56
5.2	1.00	1.00	1.00	1.00	1.00	1.02	1.05	1.07	1.10	1.15	1.20	1.26	1.28	1.30	1.36	1.45	1.53
5.3	1.00	1.00	1.00	1.00	1.00	1.01	1.04	1.06	1.09	1.14	1.18	1.24	1.26	1.28	1.34	1.42	1.50
5.4	1.00	1.00	1.00	1.00	1.00	1.00	1.03	1.05	1.08	1.13	1.17	1.22	1.24	1.25	1.32	1.39	1.48
5.5	1.00	1.00	1.00	1.00	1.00	1.00	1.02	1.04	1.07	1.12	1.16	1.21	1.22	1.23	1.30	1.37	1.45
5.6	1.00	1.00	1.00	1.00	1.00	1.00	1.01	1.03	1.06	1.11	1.15	1.19	1.20	1.22	1.28	1.34	1.43
5.7	1.00	1.00	1.00	1.00	1.00	1.00	1.00	1.02	1.05	1.10	1.14	1.18	1.19	1.20	1.26	1.32	1.41
5.8	1.00	1.00	1.00	1.00	1.00	1.00	1.00	1.01	1.04	1.09	1.13	1.16	1.17	1.18	1.25	1.30	1.38
5.9	1.00	1.00	1.00	1.00	1.00	1.00	1.00	1.00	1.03	1.08	1.12	1.15	1.16	1.17	1.23	1.28	1.36
6	1.00	1.00	1.00	1.00	1.00	1.00	1.00	1.00	1.02	1.07	1.11	1.13	1.14	1.15	1.22	1.26	1.34
6.1	1.00	1.00	1.00	1.00	1.00	1.00	1.00	1.00	1.01	1.06	1.10	1.12	1.13	1.14	1.21	1.24	1.32
6.2	1.00	1.00	1.00	1.00	1.00	1.00	1.00	1.00	1.00	1.05	1.09	1.11	1.12	1.13	1.20	1.22	1.30
6.3	1.00	1.00	1.00	1.00	1.00	1.00	1.00	1.00	1.00	1.04	1.08	1.10	1.11	1.12	1.19	1.21	1.28
6.4	1.00	1.00	1.00	1.00	1.00	1.00	1.00	1.00	1.00	1.03	1.07	1.09	1.10	1.11	1.18	1.20	1.26
6.5	1.00	1.00	1.00	1.00	1.00	1.00	1.00	1.00	1.00	1.02	1.06	1.08	1.09	1.10	1.17	1.18	1.25
6.6	1.00	1.00	1.00	1.00	1.00	1.00	1.00	1.00	1.00	1.00	1.05	1.07	1.08	1.09	1.15	1.17	1.23
6.7	1.00	1.00	1.00	1.00	1.00	1.00	1.00	1.00	1.00	1.00	1.04	1.06	1.07	1.08	1.14	1.16	1.21
6.8	1.00	1.00	1.00	1.00	1.00	1.00	1.00	1.00	1.00	1.00	1.03	1.05	1.06	1.07	1.12	1.15	1.19
6.9	1.00	1.00	1.00	1.00	1.00	1.00	1.00	1.00	1.00	1.00	1.02	1.04	1.05	1.06	1.11	1.14	1.17
7	1.00	1.00	1.00	1.00	1.00	1.00	1.00	1.00	1.00	1.00	1.00	1.03	1.04	1.05	1.08	1.13	1.15

TABLE 3 Distance Hardness Dividing Factors for Non-Boron Steels, mm

Ideal Diameter (D), mm	Jominy End-Quench Distance (mm)													
	3	5	7	9	11	13	15	20	25	30	35	40	45	50
25	1.13	1.62	2.11	2.62	2.82	2.96	3.15	3.52						
27.5	1.11	1.54	1.99	2.50	2.70	2.84	3.01	3.37						
30	1.09	1.47	1.88	2.38	2.58	2.72	2.89	3.24	3.48					
32.5	1.07	1.41	1.78	2.27	2.48	2.61	2.76	3.11	3.34	3.58				
35	1.06	1.35	1.69	2.17	2.37	2.51	2.65	2.99	3.20	3.43				
37.5	1.05	1.30	1.61	2.07	2.28	2.41	2.54	2.88	3.08	3.28	3.52			
40	1.04	1.26	1.54	1.99	2.19	2.31	2.44	2.77	2.96	3.15	3.37	3.56		
42.5	1.03	1.22	1.48	1.91	2.10	2.22	2.35	2.67	2.85	3.03	3.23	3.41	3.55	
45	1.02	1.19	1.42	1.83	2.02	2.14	2.26	2.57	2.75	2.92	3.10	3.27	3.41	3.54
47.5	1.02	1.16	1.37	1.76	1.95	2.06	2.17	2.48	2.66	2.81	2.98	3.14	3.28	3.41
50	1.01	1.13	1.33	1.70	1.87	1.99	2.10	2.40	2.57	2.71	2.87	3.03	3.16	3.29
52.5	1.01	1.11	1.29	1.64	1.81	1.92	2.02	2.32	2.48	2.62	2.77	2.92	3.05	3.18
55	1.00	1.10	1.26	1.58	1.75	1.85	1.95	2.24	2.40	2.54	2.68	2.82	2.95	3.07
57.5	1.00	1.08	1.23	1.53	1.69	1.79	1.89	2.17	2.33	2.46	2.60	2.73	2.85	2.97
60	1.00	1.07	1.21	1.48	1.63	1.74	1.83	2.10	2.26	2.39	2.52	2.65	2.76	2.88
62.5	1.00	1.06	1.18	1.44	1.58	1.68	1.77	2.04	2.19	2.32	2.45	2.57	2.68	2.79
65	1.00	1.05	1.16	1.40	1.54	1.63	1.72	1.98	2.13	2.26	2.38	2.50	2.60	2.70
67.5	1.00	1.04	1.15	1.36	1.49	1.59	1.67	1.92	2.08	2.20	2.32	2.43	2.53	2.62
70	1.00	1.04	1.13	1.33	1.45	1.54	1.63	1.87	2.02	2.14	2.26	2.37	2.46	2.55
72.5	1.00	1.03	1.12	1.30	1.41	1.50	1.58	1.82	1.97	2.09	2.20	2.31	2.40	2.48
75	1.00	1.03	1.11	1.27	1.38	1.46	1.54	1.77	1.92	2.04	2.15	2.25	2.34	2.41
77.5	1.00	1.03	1.10	1.24	1.35	1.43	1.51	1.72	1.87	1.99	2.10	2.20	2.28	2.35
80	1.00	1.02	1.09	1.22	1.32	1.40	1.47	1.68	1.83	1.95	2.06	2.15	2.22	2.29
82.5	1.00	1.02	1.08	1.20	1.29	1.37	1.44	1.64	1.79	1.90	2.01	2.10	2.17	2.23
85	1.00	1.02	1.07	1.18	1.26	1.34	1.41	1.60	1.75	1.86	1.97	2.05	2.12	2.17
87.5	1.00	1.02	1.07	1.16	1.24	1.31	1.38	1.57	1.71	1.82	1.92	2.01	2.07	2.12
90	1.00	1.02	1.06	1.14	1.22	1.29	1.35	1.53	1.67	1.78	1.88	1.96	2.03	2.07
92.5	1.00	1.01	1.05	1.13	1.20	1.27	1.33	1.50	1.64	1.75	1.84	1.92	1.98	2.02
95	1.00	1.01	1.05	1.11	1.18	1.24	1.31	1.47	1.60	1.71	1.81	1.88	1.94	1.98
97.5	1.00	1.01	1.04	1.10	1.16	1.22	1.28	1.44	1.57	1.67	1.77	1.84	1.90	1.93
100	1.00	1.01	1.04	1.09	1.15	1.21	1.26	1.41	1.54	1.64	1.73	1.80	1.86	1.89
102.5	1.00	1.01	1.03	1.08	1.13	1.19	1.24	1.39	1.51	1.61	1.70	1.76	1.82	1.85
105	1.00	1.01	1.03	1.07	1.12	1.17	1.23	1.36	1.48	1.58	1.66	1.73	1.78	1.81
107.5	1.00	1.00	1.02	1.06	1.11	1.16	1.21	1.34	1.46	1.55	1.63	1.69	1.74	1.77
110	1.00	1.00	1.02	1.05	1.10	1.15	1.19	1.32	1.43	1.51	1.59	1.65	1.71	1.73
112.5	1.00	1.00	1.02	1.04	1.08	1.13	1.18	1.29	1.41	1.49	1.56	1.62	1.67	1.70
115	1.00	1.00	1.01	1.04	1.07	1.12	1.16	1.27	1.38	1.46	1.53	1.59	1.64	1.67
117.5	1.00	1.00	1.01	1.03	1.07	1.11	1.15	1.26	1.36	1.43	1.50	1.55	1.61	1.63
120	1.00	1.00	1.01	1.03	1.06	1.10	1.14	1.24	1.34	1.40	1.47	1.52	1.58	1.60
122.5	1.00	1.00	1.01	1.02	1.05	1.09	1.12	1.22	1.31	1.38	1.44	1.49	1.55	1.57
125	1.00	1.00	1.00	1.02	1.04	1.08	1.11	1.21	1.29	1.35	1.41	1.46	1.52	1.54
127.5	1.00	1.00	1.00	1.01	1.04	1.07	1.10	1.19	1.27	1.33	1.39	1.43	1.49	1.52
130	1.00	1.00	1.00	1.01	1.03	1.06	1.09	1.18	1.25	1.31	1.36	1.41	1.46	1.49
132.5	1.00	1.00	1.00	1.01	1.02	1.05	1.08	1.16	1.24	1.28	1.34	1.38	1.44	1.47
135	1.00	1.00	1.00	1.01	1.02	1.04	1.07	1.15	1.22	1.26	1.32	1.36	1.42	1.44
137.5	1.00	1.00	1.00	1.00	1.01	1.04	1.06	1.14	1.20	1.24	1.30	1.34	1.39	1.42
140	1.00	1.00	1.00	1.00	1.01	1.03	1.05	1.13	1.19	1.22	1.28	1.32	1.37	1.40
142.5	1.00	1.00	1.00	1.00	1.00	1.02	1.04	1.12	1.17	1.21	1.26	1.30	1.35	1.38
145	1.00	1.00	1.00	1.00	1.00	1.02	1.03	1.11	1.16	1.19	1.24	1.28	1.33	1.36
147.5	1.00	1.00	1.00	1.00	1.00	1.01	1.03	1.10	1.14	1.17	1.23	1.26	1.32	1.34
150	1.00	1.00	1.00	1.00	1.00	1.00	1.02	1.09	1.13	1.16	1.21	1.25	1.30	1.33
152.5	1.00	1.00	1.00	1.00	1.00	1.00	1.01	1.08	1.12	1.15	1.20	1.23	1.29	1.31
155	1.00	1.00	1.00	1.00	1.00	1.00	1.01	1.07	1.10	1.13	1.19	1.22	1.27	1.30
157.5	1.00	1.00	1.00	1.00	1.00	1.00	1.00	1.06	1.09	1.12	1.18	1.21	1.26	1.28
160	1.00	1.00	1.00	1.00	1.00	1.00	1.00	1.05	1.08	1.11	1.17	1.20	1.24	1.27
162.5	1.00	1.00	1.00	1.00	1.00	1.00	1.00	1.05	1.07	1.10	1.16	1.19	1.23	1.26
165	1.00	1.00	1.00	1.00	1.00	1.00	1.00	1.04	1.06	1.09	1.15	1.17	1.22	1.25
167.5	1.00	1.00	1.00	1.00	1.00	1.00	1.00	1.03	1.05	1.08	1.14	1.16	1.21	1.24
170	1.00	1.00	1.00	1.00	1.00	1.00	1.00	1.02	1.04	1.07	1.13	1.15	1.20	1.23
172.5	1.00	1.00	1.00	1.00	1.00	1.00	1.00	1.01	1.03	1.06	1.12	1.14	1.18	1.22
175	1.00	1.00	1.00	1.00	1.00	1.00	1.00	1.00	1.02	1.05	1.11	1.12	1.17	1.21
177.5	1.00	1.00	1.00	1.00	1.00	1.00	1.00	1.00	1.01	1.04	1.10	1.10	1.15	1.20

TABLE 4 Distance Hardness Dividing Factors for Boron Steels, in.

Ideal Diameter (D), in.	Jominy End-Quench Distance ($\frac{1}{16}$ in.)																
	2	3	4	5	6	7	8	9	10	12	14	16	18	20	24	28	32
1.5	1.10	1.14	1.88	2.52	2.91	3.23											
1.6	1.08	1.12	1.65	2.20	2.70	3.02											
1.7	1.07	1.10	1.47	1.95	2.50	2.82	2.99										
1.8	1.06	1.09	1.34	1.74	2.31	2.63	2.83	3.00									
1.9	1.05	1.08	1.25	1.58	2.13	2.45	2.67	2.84	3.08								
2	1.04	1.07	1.19	1.46	1.97	2.28	2.51	2.68	2.88	3.33							
2.1	1.03	1.06	1.14	1.36	1.83	2.12	2.36	2.53	2.70	3.15	3.69						
2.2	1.02	1.05	1.11	1.29	1.70	1.98	2.21	2.38	2.53	2.98	3.48	3.86					
2.3	1.02	1.04	1.09	1.24	1.58	1.84	2.08	2.24	2.38	2.82	3.29	3.65					
2.4	1.02	1.04	1.08	1.20	1.48	1.72	1.95	2.11	2.24	2.67	3.11	3.45	3.63				
2.5	1.01	1.03	1.07	1.17	1.40	1.61	1.83	1.99	2.12	2.54	2.95	3.27	3.45	3.62	4.05		
2.6	1.00	1.03	1.06	1.15	1.32	1.52	1.72	1.87	2.00	2.41	2.79	3.09	3.28	3.46	3.86	4.23	
2.7	1.00	1.03	1.05	1.14	1.26	1.43	1.62	1.77	1.90	2.29	2.65	2.93	3.12	3.30	3.67	4.00	
2.8	1.00	1.02	1.05	1.13	1.21	1.36	1.53	1.67	1.80	2.18	2.52	2.78	2.97	3.15	3.50	3.78	4.27
2.9	1.00	1.01	1.04	1.12	1.17	1.30	1.44	1.59	1.72	2.08	2.40	2.65	2.83	3.01	3.34	3.59	4.01
3	1.00	1.00	1.04	1.11	1.13	1.25	1.37	1.51	1.64	1.99	2.29	2.52	2.70	2.88	3.19	3.41	3.78
3.1	1.00	1.00	1.03	1.10	1.11	1.20	1.31	1.44	1.57	1.90	2.19	2.40	2.57	2.75	3.04	3.25	3.57
3.2	1.00	1.00	1.03	1.09	1.09	1.17	1.26	1.38	1.50	1.82	2.09	2.29	2.46	2.63	2.91	3.10	3.39
3.3	1.00	1.00	1.02	1.08	1.08	1.14	1.21	1.33	1.45	1.75	2.01	2.19	2.35	2.51	2.78	2.97	3.22
3.4	1.00	1.00	1.02	1.07	1.07	1.11	1.17	1.28	1.40	1.68	1.93	2.10	2.25	2.40	2.66	2.84	3.07
3.5	1.00	1.00	1.01	1.06	1.06	1.10	1.14	1.24	1.35	1.62	1.85	2.01	2.16	2.30	2.55	2.73	2.94
3.6	1.00	1.00	1.00	1.05	1.06	1.08	1.12	1.21	1.31	1.56	1.78	1.93	2.07	2.21	2.45	2.63	2.82
3.7	1.00	1.00	1.00	1.04	1.06	1.08	1.10	1.18	1.27	1.51	1.72	1.86	1.99	2.12	2.35	2.53	2.71
3.8	1.00	1.00	1.00	1.04	1.06	1.07	1.09	1.16	1.24	1.46	1.66	1.80	1.92	2.04	2.26	2.44	2.61
3.9	1.00	1.00	1.00	1.03	1.05	1.06	1.08	1.14	1.21	1.42	1.60	1.74	1.85	1.96	2.18	2.36	2.52
4	1.00	1.00	1.00	1.02	1.05	1.06	1.07	1.13	1.19	1.38	1.55	1.68	1.79	1.89	2.11	2.29	2.44
4.1	1.00	1.00	1.00	1.02	1.05	1.06	1.07	1.12	1.17	1.35	1.50	1.63	1.73	1.82	2.03	2.22	2.37
4.2	1.00	1.00	1.00	1.01	1.04	1.06	1.06	1.11	1.15	1.31	1.46	1.58	1.68	1.76	1.97	2.15	2.30
4.3	1.00	1.00	1.00	1.01	1.03	1.05	1.06	1.10	1.13	1.28	1.42	1.54	1.63	1.71	1.91	2.09	2.23
4.4	1.00	1.00	1.00	1.01	1.03	1.05	1.06	1.09	1.11	1.25	1.38	1.50	1.58	1.66	1.85	2.03	2.17
4.5	1.00	1.00	1.00	1.00	1.02	1.04	1.06	1.09	1.10	1.23	1.35	1.47	1.54	1.61	1.80	1.98	2.11
4.6	1.00	1.00	1.00	1.00	1.01	1.04	1.06	1.08	1.09	1.21	1.32	1.43	1.51	1.57	1.75	1.93	2.06
4.7	1.00	1.00	1.00	1.00	1.01	1.03	1.05	1.08	1.08	1.19	1.29	1.40	1.47	1.53	1.71	1.88	2.01
4.8	1.00	1.00	1.00	1.00	1.01	1.03	1.05	1.07	1.07	1.17	1.26	1.37	1.44	1.50	1.67	1.83	1.96
4.9	1.00	1.00	1.00	1.00	1.02	1.02	1.04	1.06	1.06	1.15	1.24	1.35	1.41	1.47	1.63	1.79	1.91
5	1.00	1.00	1.00	1.00	1.00	1.02	1.04	1.06	1.06	1.14	1.21	1.32	1.38	1.44	1.59	1.75	1.87
5.1	1.00	1.00	1.00	1.00	1.00	1.02	1.03	1.05	1.05	1.12	1.19	1.30	1.36	1.41	1.56	1.71	1.82
5.2	1.00	1.00	1.00	1.00	1.00	1.02	1.02	1.04	1.05	1.11	1.17	1.28	1.33	1.39	1.52	1.67	1.78
5.3	1.00	1.00	1.00	1.00	1.00	1.00	1.02	1.03	1.04	1.10	1.16	1.26	1.31	1.36	1.49	1.64	1.74
5.4	1.00	1.00	1.00	1.00	1.00	1.00	1.01	1.03	1.04	1.09	1.14	1.24	1.29	1.34	1.46	1.60	1.70
5.5	1.00	1.00	1.00	1.00	1.00	1.00	1.01	1.02	1.04	1.08	1.13	1.22	1.27	1.32	1.44	1.57	1.67
5.6	1.00	1.00	1.00	1.00	1.00	1.00	1.01	1.02	1.03	1.07	1.12	1.20	1.25	1.30	1.41	1.54	1.63
5.7	1.00	1.00	1.00	1.00	1.00	1.00	1.00	1.02	1.03	1.06	1.11	1.19	1.23	1.28	1.38	1.51	1.60
5.8	1.00	1.00	1.00	1.00	1.00	1.00	1.00	1.02	1.02	1.05	1.10	1.17	1.22	1.26	1.36	1.48	1.56
5.9	1.00	1.00	1.00	1.00	1.00	1.00	1.00	1.00	1.02	1.04	1.09	1.16	1.20	1.24	1.33	1.46	1.53
6	1.00	1.00	1.00	1.00	1.00	1.00	1.00	1.00	1.01	1.04	1.08	1.14	1.18	1.23	1.31	1.43	1.50
6.1	1.00	1.00	1.00	1.00	1.00	1.00	1.00	1.00	1.00	1.01	1.03	1.07	1.13	1.17	1.21	1.28	1.41
6.2	1.00	1.00	1.00	1.00	1.00	1.00	1.00	1.00	1.00	1.02	1.07	1.12	1.15	1.19	1.26	1.38	1.44
6.3	1.00	1.00	1.00	1.00	1.00	1.00	1.00	1.00	1.00	1.02	1.06	1.10	1.14	1.17	1.23	1.35	1.41
6.4	1.00	1.00	1.00	1.00	1.00	1.00	1.00	1.00	1.00	1.01	1.05	1.09	1.12	1.15	1.21	1.33	1.38
6.5	1.00	1.00	1.00	1.00	1.00	1.00	1.00	1.00	1.00	1.01	1.04	1.08	1.11	1.13	1.18	1.30	1.35
6.6	1.00	1.00	1.00	1.00	1.00	1.00	1.00	1.00	1.00	1.00	1.03	1.07	1.09	1.12	1.16	1.27	1.32
6.7	1.00	1.00	1.00	1.00	1.00	1.00	1.00	1.00	1.00	1.00	1.02	1.06	1.08	1.10	1.14	1.25	1.29
6.8	1.00	1.00	1.00	1.00	1.00	1.00	1.00	1.00	1.00	1.00	1.01	1.05	1.07	1.08	1.11	1.21	1.25
6.9	1.00	1.00	1.00	1.00	1.00	1.00	1.00	1.00	1.00	1.00	1.00	1.05	1.06	1.07	1.09	1.18	1.21
7	1.00	1.00	1.00	1.00	1.00	1.00	1.00	1.00	1.00	1.00	1.00	1.04	1.05	1.05	1.07	1.14	1.17