



## Designation: ~~D20–03 (Reapproved 2009)~~ D20 – 03 (Reapproved 2014)

# Standard Test Method for Distillation of Road Tars<sup>1</sup>

This standard is issued under the fixed designation D20; the number immediately following the designation indicates the year of original adoption or, in the case of revision, the year of last revision. A number in parentheses indicates the year of last reapproval. A superscript epsilon ( $\epsilon$ ) indicates an editorial change since the last revision or reapproval.

*This standard has been approved for use by agencies of the U.S. Department of Defense.*

## 1. Scope

- 1.1 This test method covers the distillation of road tars.
- 1.2 The values stated in SI units are to be regarded as standard. No other units of measurement are included in this standard.
- 1.3 *This standard does not purport to address all of the safety problems, if any, associated with its use. It is the responsibility of the user of this standard to establish appropriate safety and health practices and determine the applicability of regulatory limitations prior to use.*

## 2. Referenced Documents

- 2.1 *ASTM Standards:*<sup>2</sup>  
[E1 Specification for ASTM Liquid-in-Glass Thermometers](#)

## 3. Summary of Test Method

3.1 A 100-g sample is distilled at a controlled rate from a 300-mL flask into tared receivers. The masses of distillate fractions at a series of specified temperatures and of residue at the maximum specified temperature are determined. If desired, the residue and distillates may be used for further testing.

## 4. Significance and Use

- 4.1 The distillation test separates tar into fractions according to a series of specified temperatures.

## 5. Apparatus

- 5.1 *Flask*—A side-arm distillation flask, as shown in [Fig. 1](#), conforming to the following dimensions:

Diameter of bulb, outside, mm	86.0 ± 1.5
Diameter of neck, inside, mm	22.0 ± 1.0
Diameter of side-arm, inside, mm	10.0 ± 0.5
Height of flask, outside, mm	131.0 ± 1.5
Vertical distance, bottom of bulb, outside, to horizontal tangent at side-arm, inside, mm	93.0 ± 1.5
Length of side-arm, mm	220 ± 5
Angle of side-arm, deg	75 ± 2
Thickness of side-arm wall, mm	1.0 to 1.5

- 5.2 *Condenser Tube*—A tapered glass condenser, as shown in [Fig. 2](#) and [Fig. 3](#), having the following dimensions:

Outside diameter of small end, mm	12.5 ± 1.5
Outside diameter of large end, mm	28.5 ± 3.0
Length, mm	360 ± 4
Length of uniformly tapered part, mm	100 ± 5

<sup>1</sup> This method is under the jurisdiction of ASTM Committee D04 on Road and Paving Materials and is the direct responsibility of Subcommittee D04.43 on Specifications and Test for Tar and Tar Products.

Current edition approved ~~Dec. 1, 2009~~ June 1, 2014. Published ~~January 2010~~ October 2014. Originally approved in 1911. Last previous edition approved in ~~2003~~ 2009 as ~~D20–03~~ D20 – 03 (2009). DOI: ~~10.1520/D0020-03R09~~ 10.1520/D0020-03R14.

<sup>2</sup> For referenced ASTM standards, visit the ASTM website, [www.astm.org](http://www.astm.org), or contact ASTM Customer Service at [service@astm.org](mailto:service@astm.org). For *Annual Book of ASTM Standards* volume information, refer to the standard's Document Summary page on the ASTM website.

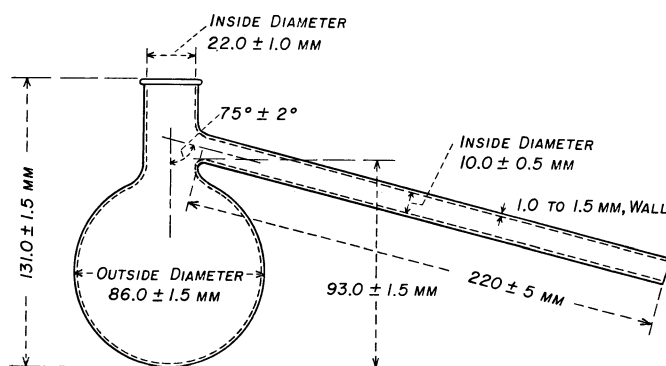

FIG. 1 Distillation Flask

5.3 *Source of Heat*— A heat source consisting of a bunsen or meker-type burner (Note 1) or an electric heater. The electric heater<sup>3</sup> shall have an output variable of 750 W and an upper refractory with dimensions as shown in Fig. 4. The temperature of the heater shall be controlled by a variable transformer or rheostat suitable for the voltage used, and shall be fitted with a clamp for mounting on a vertical support rod.

NOTE 1—An artificial gas model used with natural gas has been found to give a uniform and easily controlled source of heat.

5.4 *Flask Shield and Cover for Flame Distillation*—A steel shield (preferably stainless) lined with 3-mm Transite board, non-asbestos, with two-part cover made from 6-mm Transite board of the form and dimensions shown in Fig. 5.

5.5 *Flask Shield and Cover for Electric-Heater Distillation*—A steel shield (preferably stainless) fitted with mica windows, and a cover of the same construction and dimensions as those for flame distillation (5.4) except for the height of the shield (see Fig. 6).

5.6 *Gauze for Flame Distillation*—Two sheets of 1.0-mm opening wire gauze made of 0.56-mm diameter nickel-chromium wire measuring a minimum of 125 mm in diameter or (125 by 125-mm) square.

5.7 *Burner Chimney for Flame Distillation*—Construct a cylindrical metal shield approximately 100 mm high, 95 to 105 mm in diameter, and having a peephole 25 mm in diameter centered about 32 mm below the ring support. The top of the shield shall be flanged to permit its being suspended from the ring support.

5.8 *Receivers*—Erlenmeyer flasks or beakers having a nominal capacity of 50 to 125 mL, and tared to the nearest 0.1 g.

5.9 *Balance and Masses*, accurate to 0.1 g.

5.10 *Thermometer*—An ASTM High Distillation Thermometer having a range from  $-2$  to  $+400^{\circ}\text{C}$  and conforming to the requirements for Thermometer 8C as prescribed in Specification E1.

## 6. Preparation of Sample

6.1 Thoroughly stir or otherwise mix the sample immediately before removing the portion for testing, to ensure that such portion will be representative of the sample. If warming is necessary, take care to avoid loss of volatile material.

## 7. Preparation of Apparatus

7.1 Assemble the apparatus as follows (see Fig. 2 and Fig. 3):

7.1.1 Suspend the burner chimney by its flange from the support ring, place the specified two sheets of flat wire gauze on the burner chimney, and place the flask shield on the upper sheet of gauze. In case the electric heater is used, attach the heater to a vertical support so that at the end of the distillation it can be lowered at least 150 mm. Place the upper refractory on the heater with the larger opening facing upwards. Set the flask shield on the upper refractory.

7.1.2 Inset the thermometer through a new and rolled select quality regular-length cork of suitable size. Position the thermometer and cork in the neck of the flask so that the cork fits tightly and the bottom of the cork is from 23 to 28 mm above the lowest point of the junction between the side-arm and the neck of the flask. Then adjust the thermometer in the cork so that the top of the bulb is level with the lowest point of the juncture between the side-arm and the neck of the flask. Align the stem of the thermometer on the axis of the bulb through the neck of the flask.

7.1.3 When using the flame distillation apparatus, place the flask in the flask shield with its bulb resting on the gauze. Position the burner so that it is directly beneath the point where the bulb of the flask contacts the gauze. If the electric heater is used, place the flask in the flask shield and support the flask so that its bottom is between 4 and 7 mm above the heating coils.

<sup>3</sup> The Precision Ful-Kontrol 750-W heater with built-in variable transformer control, available from Precision Scientific Co., Chicago, IL, has been found satisfactory. This heater is only available for 115 V. 50/60 Hz. If you are aware of alternative suppliers, please provide this information to ASTM International Headquarters. Your comments will receive careful consideration at a meeting of the responsible technical committee,<sup>1</sup> which you may attend.

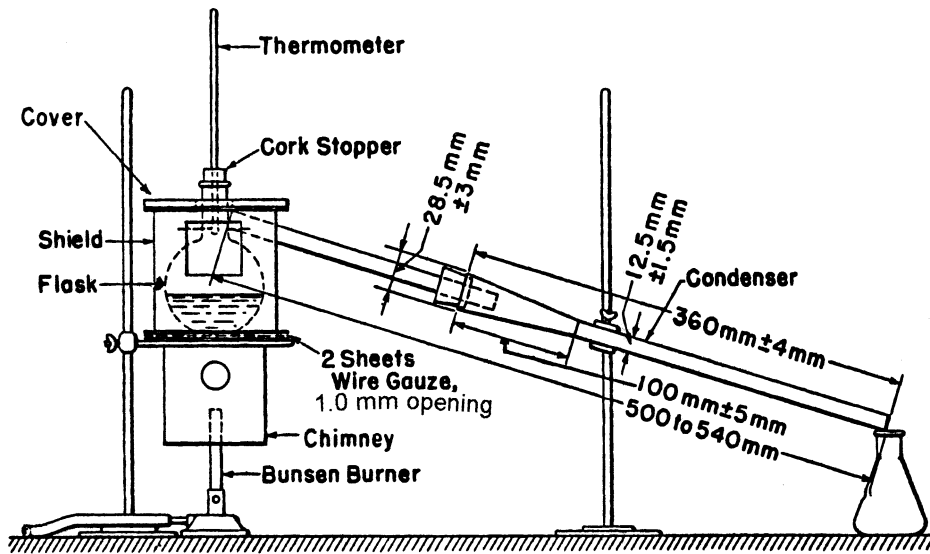

FIG. 2 Apparatus Assembly for Flame Distillation

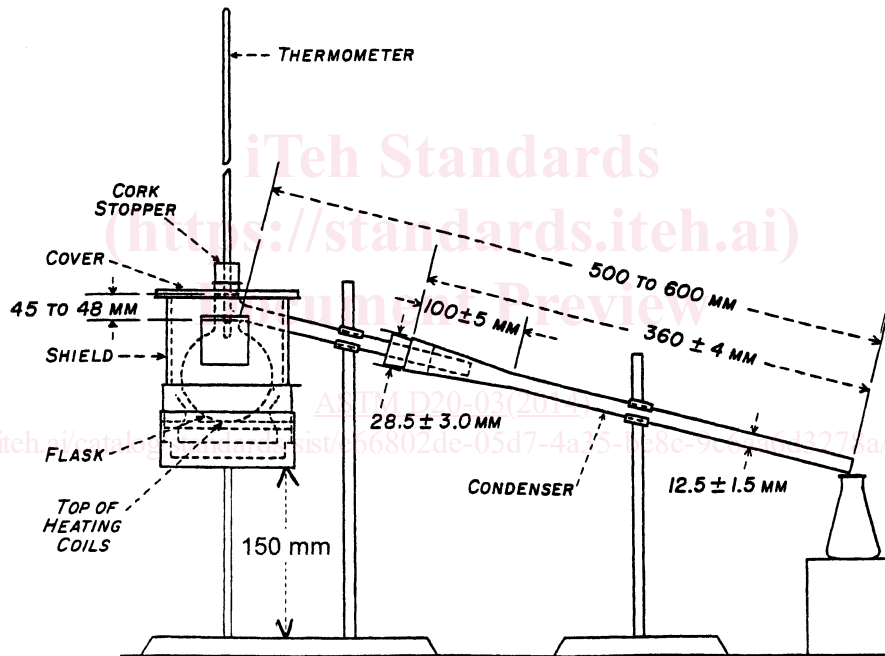

FIG. 3 Apparatus Assembly for Electric Heater Distillation

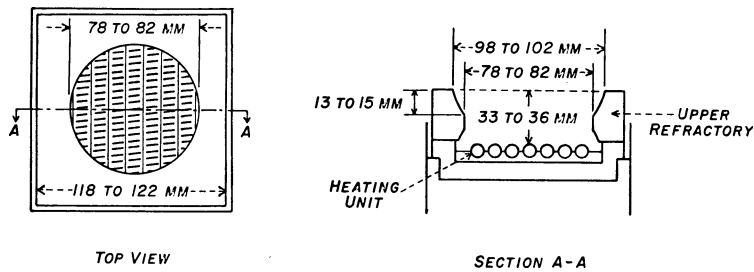

FIG. 4 Upper Part of Electric Heater

7.1.4 Connect the condenser tube to the side-arm of the flask with a tight cork joint, having the side-arm project 30 to 50 mm through the cork. The distance from the neck of the flask to the outlet end of the condenser tube shall be between 500 and 600