



Designation: **F3022 – 13 F3022 – 14**

# Standard Test Method for Evaluating the Universal Design of Fitness Equipment for Inclusive Use by Persons with Functional Limitations and Impairments<sup>1</sup>

This standard is issued under the fixed designation F3022; the number immediately following the designation indicates the year of original adoption or, in the case of revision, the year of last revision. A number in parentheses indicates the year of last reapproval. A superscript epsilon ( $\epsilon$ ) indicates an editorial change since the last revision or reapproval.

## INTRODUCTION

The goal of this test method is to provide reliable and repeatable methods for the evaluation of universally designed fitness equipment.

The equipment user must recognize, however, that the standard alone will not necessarily prevent injuries. Like other physical activities, exercise involving fitness equipment involves the risk of injury, particularly if the equipment is used improperly or not properly maintained. In addition, users with physical limitations should seek medical advice and instruction from the fitness facility prior to using this equipment. Certain physical conditions or limitations may preclude some persons from using the equipment properly and without increasing the risk of serious injury.

## 1. Scope

1.1 This test method<sup>2</sup> specifies procedures and equipment used for testing and evaluating the accessibility of fitness equipment for compliance to Specification **F3021** design parameters. Where possible and applicable, accepted test methods from other recognized bodies will be used and referenced. In case of a conflict between this document and Specification **F3021**, Specification **F3021** takes precedence.

1.2 This test method is to be used in conjunction with Specification **F3021**.

1.3 This standard is to be used as additional requirements to address the accessibility of the equipment for persons with disabilities.

NOTE 1—Additional test methods applicable to specific pieces of equipment, such as treadmills, bicycles, ellipticals, and strength equipment are currently under development.

1.4 The values stated in SI units are to be regarded as the standard. The values given in parentheses are for information only.

1.5 *This standard does not purport to address all of the safety concerns, if any, associated with its use. It is the responsibility of the user of this standard to establish appropriate safety and health practices and determine the applicability of regulatory limitations prior to use.*

## 2. Referenced Documents

2.1 *ASTM Standards:*<sup>3</sup>

**E177** Practice for Use of the Terms Precision and Bias in ASTM Test Methods

**E691** Practice for Conducting an Interlaboratory Study to Determine the Precision of a Test Method

**F2571** Test Methods for Evaluating Design and Performance Characteristics of Fitness Equipment

**F3021** Specification for Universal Design of Fitness Equipment for Inclusive Use by Persons with Functional Limitations and Impairments

<sup>1</sup> This test method is under the jurisdiction of ASTM Committee **F08** on Sports Equipment, Playing Surfaces, and Facilities and is the direct responsibility of Subcommittee **F08.30** on Fitness Products.

Current edition approved June 1, 2013; Sept. 1, 2014. Published July 2013; October 2014. Originally approved in 2013. Last previous edition approved in 2013 as F3022 – 13. DOI: 10.1520/F3022-13.10.1520/F3022-14.

<sup>2</sup> This work was funded, in part, by the Rehabilitation Engineering Research Center on RecTech through the National Institute on Disability and Rehabilitation Research under the US Department of Education grant #H133E070029 and H133120005.

<sup>3</sup> For referenced ASTM standards, visit the ASTM website, [www.astm.org](http://www.astm.org), or contact ASTM Customer Service at [service@astm.org](mailto:service@astm.org). For *Annual Book of ASTM Standards* volume information, refer to the standard's Document Summary page on the ASTM website.

### 3. Terminology

3.1 *Definitions*—For definitions applicable to this standard see Specification F3021.

### 4. Certification

4.1 These test methods permit self-certification. It is recommended that each manufacturer employ an independent laboratory to evaluate and validate that their designs and test procedures conform and comply with these test methods and Specification F3021.

NOTE 2—The test methods and procedures described in Section 7 should be supported by conducting user testing using subjects across a range of disabilities, impairments, and ages and those without disability on the sample equipment.

### 5. Sample Preparation

5.1 Assemble and adjust the fitness equipment apparatus on a horizontal surface according to the manufacturer's instructions. Verify that assembled units are done so according to the manufacturer's instructions. Unless otherwise stated, the fitness equipment apparatus must pass the following tests without adjustment from this initial condition.

5.2 Any equipment with a removable/movable seat shall be set up with the seat in the non-moved position.

5.3 The individual test methods will describe any variations or modifications that are required to the test sample.

### 6. Report

6.1 *Record of Tests*—Maintain complete test records and test summary reports for all testing, whether performed by the manufacturer or an independent laboratory. The records can be stored on paper, electronically, or on photographs, or a combination thereof. A copy of the test summary must be kept by the laboratory that performed the test for a minimum of five years from the date of the test and by the manufacturer for a minimum of five years past the end of production of the model tested. The summary shall include the signature of the person(s) performing the tests and a management representative of the laboratory performing the test. The test summary shall include the following information:

6.1.1 Manufacturer's name and location,

6.1.2 Information provided by the manufacturer to accurately identify the configuration of, and specific unit provided to, the testing agency,

6.1.3 Dates over which the tests were conducted,

6.1.4 Name and location of the testing laboratory, if different from the manufacturer, and

6.1.5 Summary and results of each test performed including method and apparatus used. This shall include what the desired requirement was and whether the test sample met that parameter or failed. If the test requires a specific number of cycles to be met, then the report must include the number of cycles actually conducted. If the apparatus fails to meet a parameter, then that failure must be noted in clear and accurate terms to enable a reader of the report to understand at a later date what transpired.

### 7. Test Methods and Procedures

7.1 *General Requirements:*

7.1.1 *Access and Set Up:*

7.1.1.1 *Access, Egress, and Transfer*—This test is a visual inspection of the sample to ensure that all access paths to the piece of equipment, set in the start position, are not obstructed by the frame or other structural parts of the equipment.

*Apparatus and Set Up*—The sample shall be set up as described in Section 5.

*Calibration*—No calibration required. Visual inspection only.

*Procedure*—Inspect all access paths to verify that the path is clear of any obstruction by the frame or other structural parts.

*Pass/Fail Criteria*—The access path shall conform to the clear space requirements of subsection 5.1.1.1 of Specification F3021.

*Precision and Bias*—No information is presented about either the precision or bias of test 7.1.1.1 for evaluating access since the test result is non-quantitative.

NOTE 3—Performance tests to get on/off the equipment from the perspective of a broad range of people with disabilities, including people using wheelchairs or those who have functional limitations, sensory deficits, cognitive impairments, visual, or hearing impairments, or a combination thereof, is suggested. One possible method would be to use testers with disabilities.

7.1.1.2 *Maximum Approach Positions*—This test is a visual inspection of the sample to ensure that access paths to the piece of equipment, set in the start position, are available from as many positions as possible (i.e., that is, front, rear, left, and right).

*Apparatus and Set Up*—The sample shall be set up as described in Section 5.

*Calibration*—No calibration required. Visual inspection only.

*Procedure*—Inspect access paths from the front, rear, left, and right of the equipment to verify that the path is clear of any obstruction by the frame or other structural parts from as many points of access as possible.

*Pass/Fail Criteria*—Equipment must be accessible and shall avoid left/right bias as specified in the requirements of subsection 5.1.1.2 of Specification F3021. There is no pass/fail criteria.

*Precision and Bias*—Equipment must be accessible and shall avoid left/right bias as specified in the requirements of subsection 5.1.1.2 of Specification F3021. There is no pass/fail criteria.

7.1.1.3 *Step-On Height*—This test is a dimensional inspection of the sample to ensure the dimensional compliance of the step-on height.

*Apparatus and Set Up*—The sample shall be set up as described in Section 5 in the neutral position with 0% grade/zero incline.

*Calibration*—Verify that the distance measuring equipment is calibrated and accurate to within 1 mm (0.040 in.).

*Procedure*—Measure the height from the floor to the top of the highest portion of the step-on surface/frame or top of the transfer surface (see Fig. 1).

*Pass/Fail Criteria*—The dimensions of the step-on height shall conform to dimensional requirements of subsection 5.1.1.3 of Specification F3021.

*Precision and Bias*—No information is presented about either the precision or bias of test 7.1.1.3 for measuring step-on height dimensions since the test result is non-quantitative.

7.1.1.4 *Step-Over Height*—This test is a dimensional inspection of the sample to ensure the dimensional compliance of the step-over height.

*Apparatus and Set Up*—The sample shall be set up as described in Section 5.

*Calibration*—Verify that the distance measuring equipment is calibrated and accurate to within 1 mm (0.040 in.).

*Procedure*—Locate the part of the structure that must be stepped over in order to use the equipment. Measure the distance from the floor to the top of the highest step-over point of the frame (see Fig. 2).

*Pass/Fail Criteria*—The dimensions of the step-over height shall conform to dimensional requirements of subsection 5.1.1.4 of Specification F3021.

*Precision and Bias*—No information is presented about either the precision or bias of test 7.1.1.4 for measuring step-over height dimensions since the test result is non-quantitative.

7.1.1.5 *Integral Surface/Separate Step Height*—This test is a dimensional inspection of the sample to ensure the dimensional compliance of the ~~step-over~~step-on/step-over height, with the addition of an integral surface or separate step.

*Apparatus and Set Up*—The sample shall be set up as described in Section 5 with an integral surface or separate step intact.

*Calibration*—Verify that the distance measuring equipment is calibrated and accurate to within 1 mm (0.040 in.).

*Procedure*—~~Measure the height of the~~Locate the part of the structure that must be stepped ~~over~~on/over in order to use the equipment. Measure the distance from the surface of the integral surface or separate step to the top of the highest step-over point of the frame (see 7.1.1.4).

*Pass/Fail Criteria*—The dimensions of the integral surface or separate step height shall conform to dimensional requirements of subsection 5.1.1.5 of Specification F3021.

*Precision and Bias*—No information is presented about either the precision or bias of test 7.1.1.5 for measuring integral surface or separate step height dimensions since the test result is non-quantitative.

7.1.1.6 *Integral Surface/Separate Step Length/Width=Length/Width/Height*—This test is a dimensional inspection of the sample to ensure the dimensional compliance of the integral surface and separate step ~~length-length, width, and width-height.~~ length-length, width, and width-height.

*Apparatus and Set Up*—The sample shall be set up as described in Section 5 with an integral surface or separate step intact.

*Calibration*—Verify that the distance measuring equipment is calibrated and accurate to within 1 mm (0.040 in.).

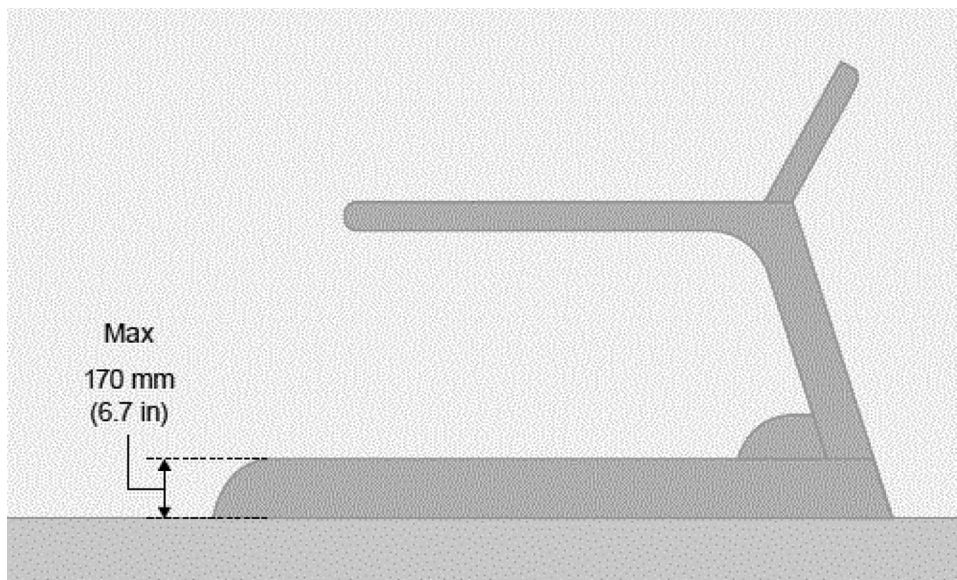

FIG. 1 Maximum Step-on Height Example

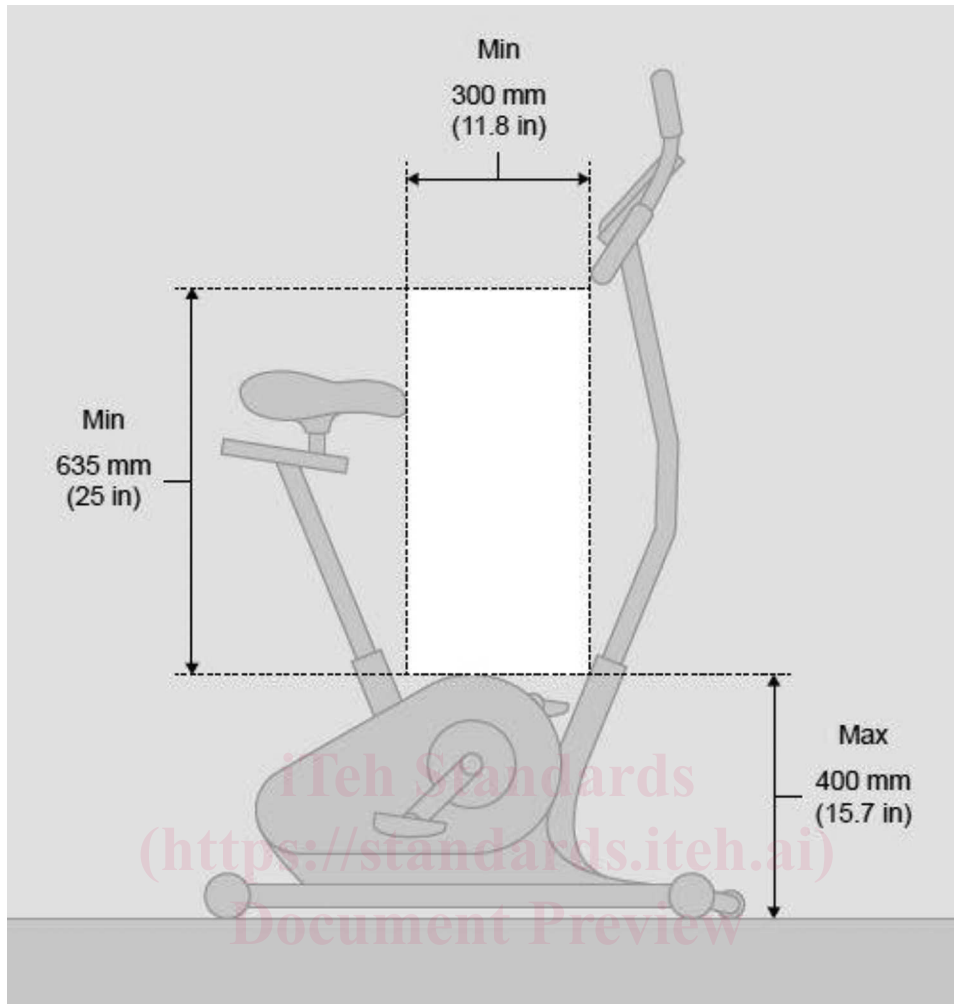

FIG. 2 Maximum Step-over Height Example

<https://standards.iteh.ai/catalog/standards/sist/b368c44c-d4f9-4a13-9617-619b3f699e59/astm-f3022-14>

*Procedure*—Measure the height from the floor to the top of the stepping surface of the integral surface or separate step. Measure the length and width from the outer edge of the stepping surface lengthwise and the outer edge of the stepping surface widthwise on the integral surface or separate step.

*Pass/Fail Criteria*—Measure the height from the floor to the top of the stepping surface of the integral surface or separate step. Measure the length and width from the outer edge of the stepping surface lengthwise and the outer edge of the step length/width/height shall conform to dimensional requirements of subsection 5.1.1.6 of Specification F3021 stepping surface widthwise on the integral surface or separate step.

*Precision and Bias*—No information is presented about either the precision or bias of test 7.1.1.6 for measuring integral surface and separate step length, width, and height dimensions since the test result is non-quantitative.

7.1.1.7 *Integral Surfaces/Separate Steps—Significant Color Contrast*—Perform the color value measurement test in Section 7.3.

7.1.1.8 *Intentional/Unintentional Movement*—This test is a performance and dimensional inspection of the sample to ensure that separate steps do not unintentionally move during use and that they have appropriate mechanisms to facilitate intentional movement.

*Apparatus and Set Up*—The sample shall be set up as described in Section 5 on carpet for testing the ease of moving the step and on tile or similar flooring for testing for unintentional movement during use.

*Calibration*—Verify that the force measuring equipment is calibrated and accurate to within 0.5 N (0.1 lbf) over its entire range.

*Procedure*—Check for skids or wheel lock mechanism. Step on/off the step on tile or similar flooring and visually inspect for unintentional movement during use. Pull the step over carpet flooring and measure the pull force.

*Pass/Fail Criteria*—The step unintentional/intentional movement shall conform to performance requirements of subsection 5.1.1.8 of Specification F3021.

*Precision and Bias*—No information is presented about either the precision or bias of test 7.1.1.8 for evaluating and measuring step unintentional/intentional movement since the test result is non-quantitative.

7.1.1.9 *Walk Through Structure Clear Area*—This test is a performance inspection of the sample to ensure the dimensional compliance of walk through structure height.

*Apparatus and Set Up*—The sample shall be set up as described in Section 5.

*Calibration*—Verify that the distance measuring equipment is calibrated and accurate to within 1 mm (0.040 in.).

*Procedure*—Step through the walk through area of the equipment. Make sure that there is adequate low structure height to step through without impediment or obstruction. Measure the height from the floor to the highest part of the walk through structure.

*Pass/Fail Criteria*—The dimensions of the walk through structure area shall conform to dimensional requirements of subsection 5.1.1.9 of Specification F3021.

*Precision and Bias*—No information is presented about either the precision or bias of test 7.1.1.9 for measuring walk through structure area dimensions since the test result is non-quantitative.

7.1.1.10 *Recumbent Walk Through Transition Area Box*—This test is a dimensional inspection of the sample to ensure the dimensional compliance of walk through structure area.

*Apparatus and Set Up*—The sample shall be set up as described in Section 5.

*Calibration*—Verify that the distance measuring equipment is calibrated and accurate to within 1 mm (0.040 in.).

*Procedure*—Measure the height and width of the transition area (see Fig. 3).

*Pass/Fail Criteria*—The dimensions of the transition area box shall conform to dimensional requirements of subsection 5.1.1.10 of Specification F3021.

*Precision and Bias*—No information is presented about either the precision or bias of test 7.1.1.10 for measuring the transition area box dimension since the test result is non-quantitative.

7.1.1.11 *Hand/Foot Support Locking Mechanism*—This test is a performance inspection of the sample to ensure that the hand/foot supports lock in place during mounting/dismounting.

*Apparatus and Set Up*—The sample shall be set up as described in Section 5.

*Calibration*—No calibration required. Performance test only.

*Procedure*—Adjust the hand/foot supports for mounting and verify that they are able to be locked in place.

*Pass/Fail Criteria*—The hand/foot support locking mechanism shall conform to the requirements of subsection 5.1.1.11 of Specification F3021.

*Precision and Bias*—No information is presented about either the precision or bias of test 7.1.1.11 for evaluating the hand/foot support locking mechanism since the test result is non-quantitative.

7.1.1.12 *Highlight Potential Trip Hazards—Significant Color Contrast*—Perform the color value measurement test in Section 7.3.

7.1.2 *Seats, Sitting Surfaces, and Back Supports:*

7.1.2.1 *Sitting Surface Width/Depth/Back Support Angle*—This test is a dimensional inspection of the sample to ensure the dimensional compliance of the seat/sitting surface width, depth, and back support angle.

*Apparatus and Set Up*—The sample shall be set up as described in Section 5.

<https://standards.iteh.ai/catalog/standards/sist/b368c44c-d4f9-4a13-9617-619b3f699e59/astm-f3022-14>

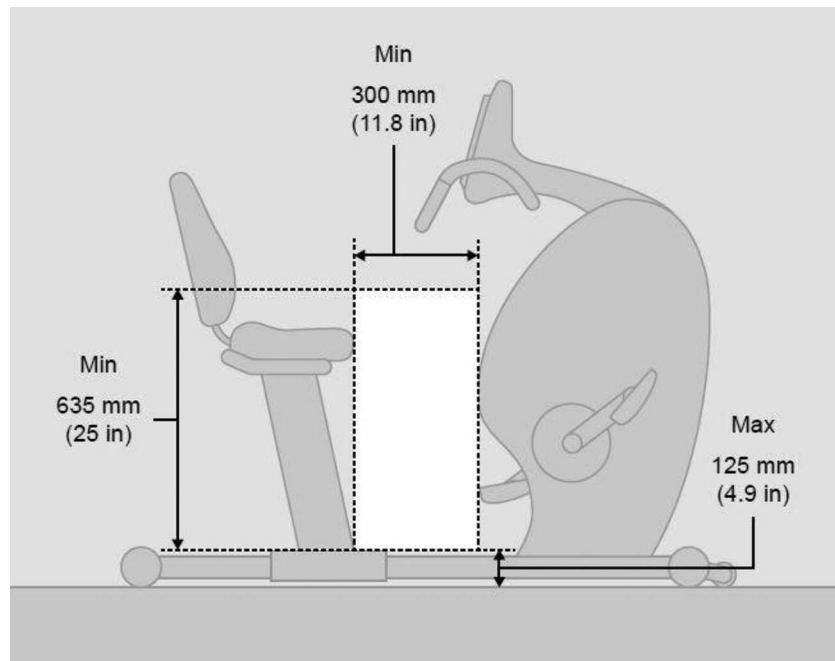

FIG. 3 Minimum Dimensions for Transition Area Box

**Calibration**—Verify that the distance measuring equipment is calibrated and accurate to within 1 mm (0.040 in.) and the angle measuring equipment is calibrated and accurate to within 0.1°.

**Procedure**—Measure the width across the top of the sitting support surface from the left outer side edge to the right outer side edge at the widest point in the hip/pelvic area. Measure the depth of the top of the sitting support surface from the front edge of the hip/pelvic area to the back edge through the centerline. If the seat/sitting surface has a back support, measure the seat angle in the middle on top of the hip/pelvic support area from the horizontal reference of the floor (see Fig. 4).

**Pass/Fail Criteria**—The dimensions of the seat/sitting surface width, height, depth, and back support angle shall conform to dimensional requirements of subsection 5.1.2.1 of Specification F3021.

**Precision and Bias**—No information is presented about either the precision or bias of test 7.1.2.1 for measuring sitting surface width, depth, and back support angle dimensions since the test result is non-quantitative.

**7.1.2.2 Fixed Seat Height**—This test is a dimensional inspection of the sample to ensure the dimensional compliance of the seat height.

**Apparatus and Set Up**—The sample shall be set up as described in Section 5.

**Calibration**—Verify that the distance measuring equipment is calibrated and accurate to within 1 mm (0.040 in.).

**Procedure**—Measure the height of the seat from the ground to the top of the sitting surface (see Fig. 5).

**Pass/Fail Criteria**—The dimensions of the seat height shall conform to dimensional requirements of subsection 5.1.2.2 of Specification F3021.

**Precision and Bias**—No information is presented about either the precision or bias of test 7.1.2.2 for measuring fixed seat height dimensions since the test result is non-quantitative.

**7.1.2.3 Adjustable Seat Height Range**—This test is a dimensional inspection of the sample to ensure that there is a seat height option within the specified range on adjustable seats.

**Apparatus and Set Up**—The sample shall be set up as described in Section 5.

**Calibration**—Verify that the distance measuring equipment is calibrated and accurate to within 1 mm (0.040 in.).

**Procedure**—Measure the height of the seat from the ground to the top of the sitting surface with the seat in the lowest and highest position. Verify that the seat height can be adjusted within the specified range.

**Pass/Fail Criteria**—The dimensions of the adjustable seat height range shall conform to dimensional requirements of subsection 5.1.2.3 of Specification F3021.

**Precision and Bias**—No information is presented about either the precision or bias of test 7.1.2.3 for measuring the adjustable seat height range shall conform to dimensional requirements of subsection 5.1.2.3 of Specification since the test result is non-quantitative. F3021.

**7.1.2.4 Seat Height Adjustability**—This test is a performance inspection of the sample to ensure that the seat height is adjustable.

**Apparatus and Set Up**—The sample shall be set up as described in Section 5.

**Calibration**—No calibration required. Performance test only.

**Procedure**—Verify that the seat height is adjustable. Adjust the seat from lowest to highest position.

**Pass/Fail Criteria**—The seat height adjustability shall conform to the requirements of subsection 5.1.2.4 of Specification F3021.

**Precision and Bias**—No information is presented about either the precision or bias of test 7.1.2.4 for measuring the seat height adjustability shall conform to the requirements of subsection 5.1.2.4 of Specification since the test result is non-quantitative. F3021.

**7.1.2.5 Removable/Movable Seat**—This test is a dimensional inspection of the sample to ensure that the clear space and floor area is free of obstacles when a removable/movable seat is removed/moved.

**Apparatus and Set Up**—The sample shall be set up as described in Section 5.

**Calibration**—Verify that the distance measuring equipment is calibrated and accurate to within 1 mm (0.040 in.).

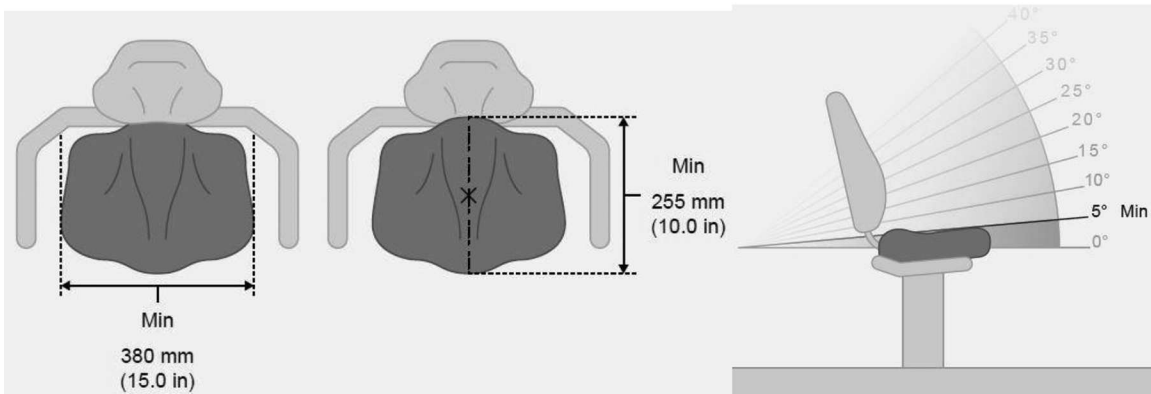

FIG. 4 Minimum Seat Dimensions – Width, Depth, Angle

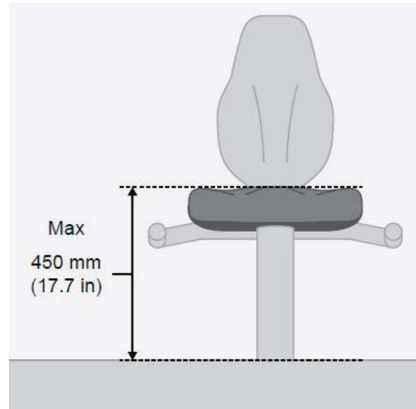

FIG. 5 MinimumMaximum Seat Dimensions – Height

*Procedure*—Remove/Move the seat from its active position to its storage position. Measure the length, width, and height of the accessible clear space area. Measure the height of any obstacle(s) that remain in the accessible clear space in the floor area.

*Pass/Fail Criteria*—The seat shall be capable of being removed/moved into a storage position with an accessible clear space floor area that conforms to the requirements of subsection 5.1.2.5 of Specification F3021.

*Precision and Bias*—No information is presented about either the precision or bias of test 7.1.2.5 for evaluating and measuring seat removability/movability, clear space, and obstacle height since the test result is non-quantitative.

NOTE 4—Reminder when testing for stability of the equipment, the seat in the removed/moved position would be the most onerous position for testing.

7.1.2.6 *Start Position/Hand Grip(s) Clearance*—This test is a dimensional inspection of the sample to ensure that when removable/movable seats are removed/moved, that there is sufficient distance between the back support and exercise hand grips when a wheelchair is in the exercise position.

*Apparatus and Set Up*—The sample shall be set up as described in Section 5.

*Calibration*—Verify that the distance measuring equipment is calibrated and accurate to within 1 mm (0.040 in.).

*Procedure*—Remove/Move the seat from its active position to its storage position. Measure the horizontal distance between the closest start position of the hand grips designed for wheelchair use and the back support (see Fig. 7).

*Pass/Fail Criteria*—The start position and hand grip(s) clearance shall conform to the requirements of subsection 5.1.2.6 of Specification F3021.

*Precision and Bias*—No information is presented about either the precision or bias of test 7.1.2.6 for evaluating and measuring start position and hand grip(s) clearance since the test result is non-quantitative.

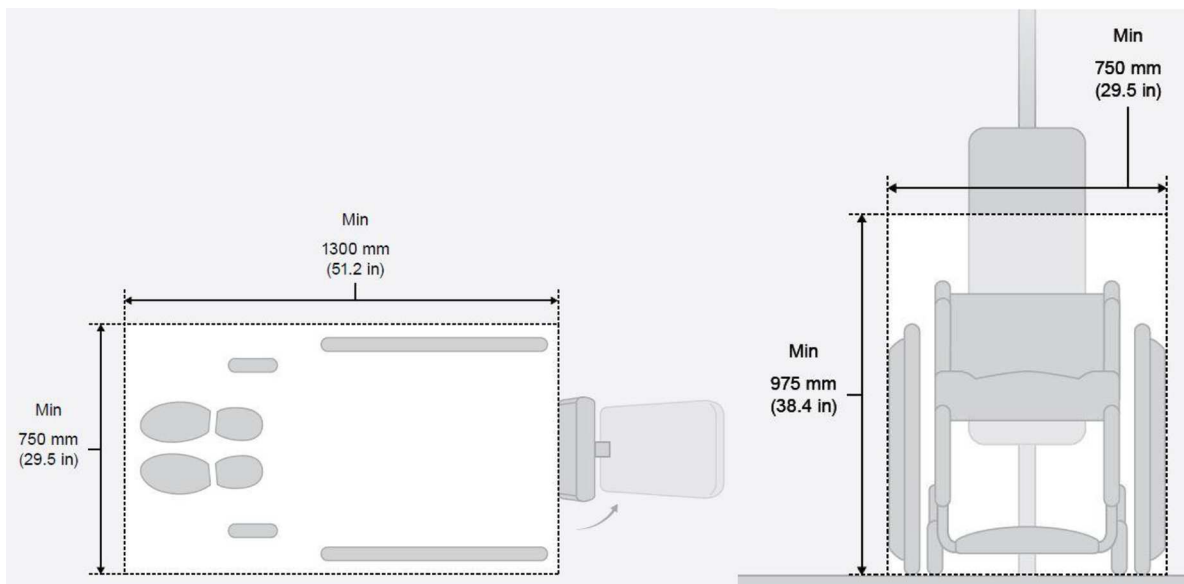

FIG. 6 Removable/Movable Minimum Clear Space Area

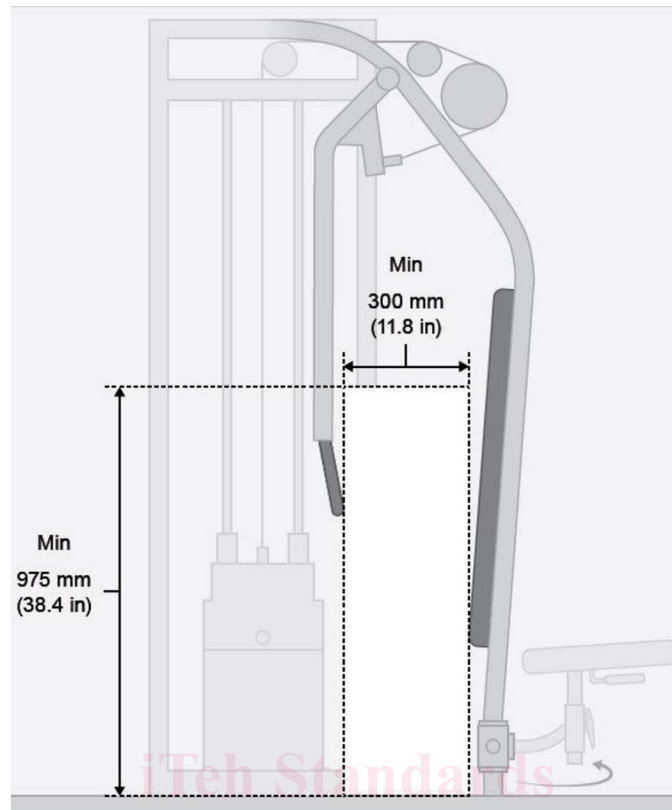

FIG. 7 Minimum Distance from Back Support to Hand Grips with Seat Removed

7.1.2.7 *Seats Intentional/Unintentional Movement*—This test is a visual, performance, and dimensional inspection of the sample to ensure that removable/movable seats have appropriate mechanisms, for example, wheels or skids and hand grips or gripping surfaces, to enable the seat to move easily over different floor surfaces and a means of preventing unintentional movement during use.

*Apparatus and Set Up*—The sample shall be set up as described in Section 5 on carpet for testing the ease of moving the seat and on tile or similar flooring for testing for unintentional movement during use.

*Calibration*—Verify that the force measuring equipment is calibrated and accurate to within 0.5 N (0.1 lbf) over its entire range.

*Procedure*—Inspect the sample for skids or wheel lock mechanism. Remove/Move the seat from its active position to its storage position over carpet flooring and measure the pull force. Visually inspect for unintentional movement during use while on tile or similar flooring.

*Pass/Fail Criteria*—The seat intentional/unintentional movement shall conform to performance requirements of subsection 5.1.2.7 of Specification F3021.

*Precision and Bias*—No information is presented about either the precision or bias of test 7.1.2.7 for evaluating and measuring seat unintentional/intentional movement since the test result is non-quantitative.

7.1.2.8 *Physical Locating/Locking Mechanism*—This test is a performance inspection of the sample to ensure that seats with a specific exercise position have a physical locating or locking mechanism or a visual reference to indicate the correct seat alignment.

*Apparatus and Set Up*—The sample shall be set up as described in Section 5 with the seat removed.

*Calibration*—No calibration required. Performance test only.

*Procedure*—Verify that there is a physical locating or locking mechanism or a visual reference to indicate the correct seat alignment. Have an untrained tester move the seat into the specific exercise position, verify that the seat is in the correct position.

*Pass/Fail Criteria*—The seat position shall conform to the requirements of subsection 5.1.2.8 of Specification F3021.

*Precision and Bias*—No information is presented about either the precision or bias of test 7.1.2.8 for evaluating physical locating/locking mechanism since the test result is non-quantitative.

7.1.2.9 *Postural Support/Surface Padding*—This test is a dimensional inspection of the sample to ensure that postural support/surfaces are cleanable and padded.

*Apparatus and Set Up*—The sample shall be set up as described in Section 5.

*Calibration*—Verify that the distance measuring equipment is calibrated and accurate to within 1 mm (0.040 in.).



*Procedure*—Verify that the postural supports/surfaces can be sanitized from sweat and other bodily fluids. Measure the depth of the foam used in each postural support/surface and verify that the hardness and density meet the specified ISO requirements.

*Pass/Fail Criteria*—The postural supports/surfaces padding shall conform to the requirements of subsection 5.1.2.9 of Specification F3021.

*Precision and Bias*—No information is presented about either the precision or bias of test 7.1.2.9 for evaluating and measuring postural support/surface padding since the test result is non-quantitative.

7.1.2.10 *Seats—Significant Color Contrast*—Perform the color value measurement test in Section 7.3.

7.1.3 *Adjustment Mechanisms:*

7.1.3.1 *Visible Adjustment Mechanisms*—This test is a visual and performance inspection of the sample to ensure that adjustment mechanisms required for set up are visible in a clear line of sight to the user upon approach to the equipment or from the primary exercise position, or both.

*Apparatus and Set Up*—The sample shall be set up as described in Section 5 with the seat in place and removed/moved.

*Calibration*—No calibration required. Visual/performance test only.

*Procedure*—Verify that the adjustment mechanisms are in a clear line of sight without obstruction from the primary exercise position with the seat in place and removed/moved. Perform set up adjustments from the approach position and the primary exercise position with the seat in place and removed/moved.

*Pass/Fail Criteria*—The visible adjustment mechanisms shall conform to the requirements of subsection 5.1.3.1 of Specification F3021.

*Precision and Bias*—No information is presented about either the precision or bias of test 7.1.3.1 for evaluating visible adjustment mechanisms since the test result is non-quantitative.

7.1.3.2 *Left/Right Hand Bias Adjustment Mechanisms*—This test is a performance inspection of the sample to ensure that adjustment mechanisms are not left or right hand biased.

*Apparatus and Set Up*—The sample shall be set up as described in Section 5 with the seat in place and removed/moved.

*Calibration*—No calibration required. Performance test only.

*Procedure*—Make all adjustments using the left hand and then repeat using the right hand with the seat in place and removed/moved.

*Pass/Fail Criteria*—The left/right hand bias adjustment mechanisms shall conform to the requirements of subsection 5.1.3.2 of Specification F3021.

*Precision and Bias*—No information is presented about either the precision or bias of test 7.1.3.2 for evaluating left/right hand bias adjustment mechanisms since the test result is non-quantitative.

7.1.3.3 *One Hand Adjustment Mechanisms*—This test is a performance inspection of the sample to ensure that adjustment mechanisms can be performed with one hand.

*Apparatus and Set Up*—The sample shall be set up as described in Section 5.

*Calibration*—No calibration required. Performance test only.

*Procedure*—Make all adjustments, except those requiring a carabiner, using only one hand.

*Pass/Fail Criteria*—The adjustments shall conform to the requirements of subsection 5.1.3.3 of Specification F3021.

*Precision and Bias*—No information is presented about either the precision or bias of test 7.1.3.3 for evaluating one hand adjustment mechanisms since the test result is non-quantitative.

7.1.3.4 *Adjustment Mechanism Ease of Use*—This test is a visual and performance inspection of the sample to ensure that adjustment mechanisms required for set up are easy to use.

*Apparatus and Set Up*—The sample shall be set up as described in Section 5.

*Calibration*—No calibration required. Visual/performance test only.

*Procedure*—Verify that the adjustment mechanisms are within reach from the primary exercise position by a 5% size female. 5 % size female (see Table 1). Perform set up adjustments and verify that the adjustment mechanisms can be easily inserted/removed and do not require fine finger control, excessive wrist rotation, tight grasp, or a pinch grip (see Figs. 8 and 9).

*Pass/Fail Criteria*—The adjustment mechanism ease of use shall conform to the requirements of subsection 5.1.3.4 of Specification F3021.

*Precision and Bias*—No information is presented about either the precision or bias of test 7.1.3.4 for evaluating adjustment mechanism ease of use since the test result is non-quantitative.

TABLE 1 Dimensions of US Civilian Male and Females<sup>A</sup>

Dimension Name	5th Percentile Female (in.)	Mean (Average) Male (in.)	Mean (Average) Female (in.)	Mean (Average) Overall (in.)	95th Percentile Male (in.)
Height	58.9	68.21	63.10	65.66	72.6
Sitting Height, Erect	30.9	35.61	33.34	34.48	38.1

<sup>A</sup>Source: Anthropology Research Project Staff, *Anthropometric Source Book, Volume 2. Anthropometry for Designers*, NASA Reference Publication 1024, NASA, Houston, TX, 1978.

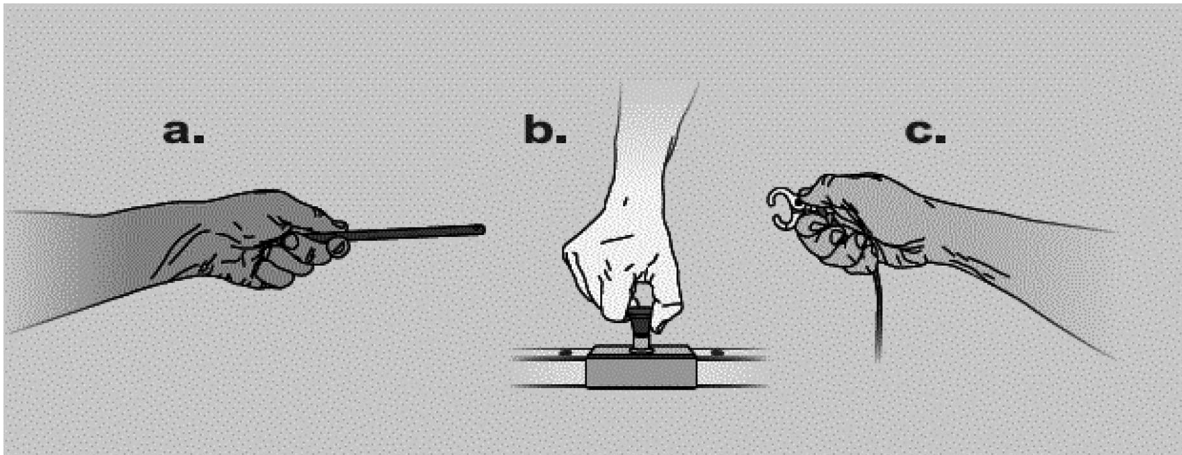

FIG. 8 Non-Accessible Hand Grips: (a) Twist, (b) Tight Grasp, and (c) Pinch

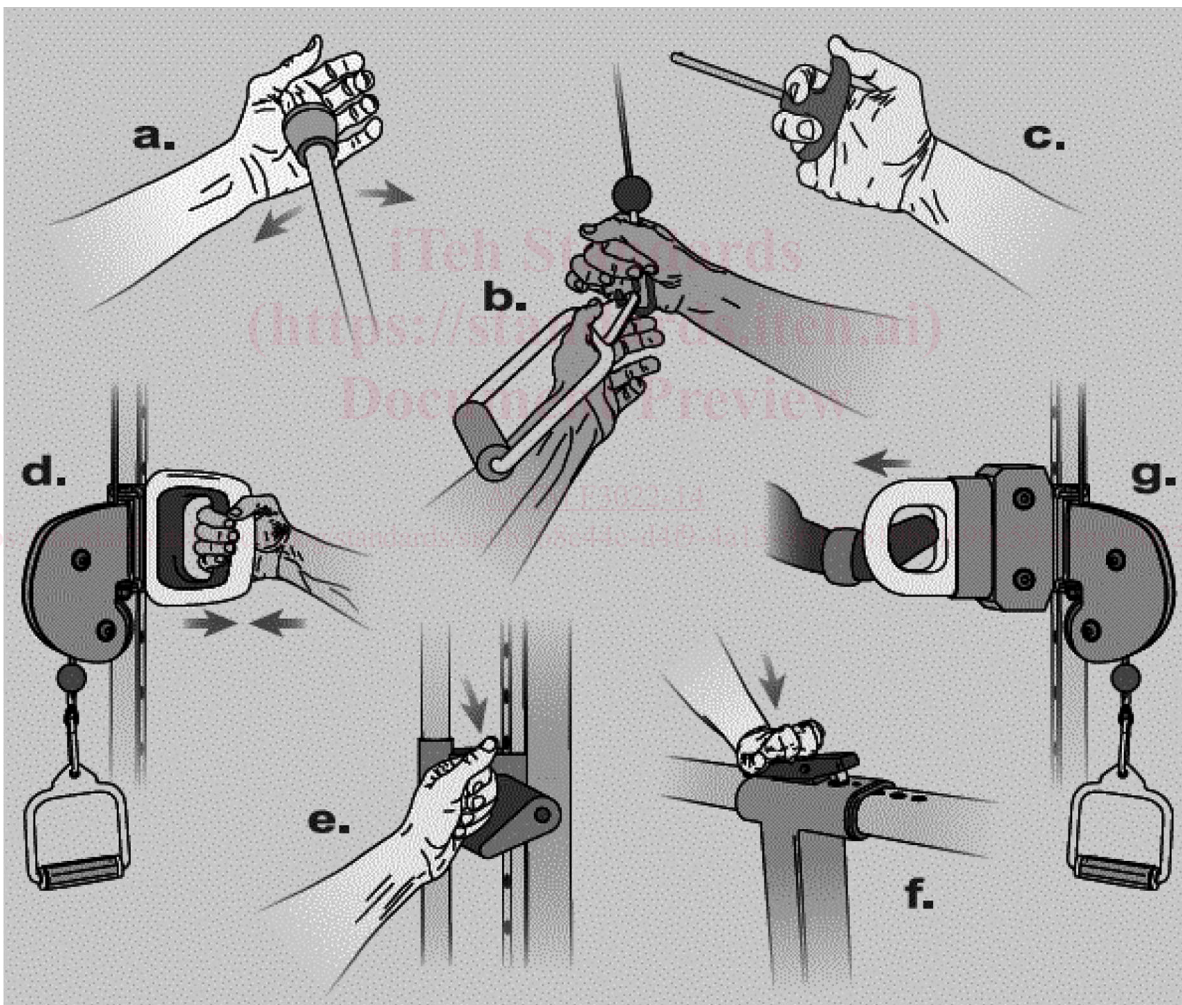

FIG. 9 Accessible Hand Grips

7.1.3.5 *Adjustment Mechanism Force*—This test is a dimensional inspection of the sample to ensure that adjustment mechanisms are easy to activate.

*Apparatus and Set Up*—The sample shall be set up as described in Section 5.

*Calibration*—Verify that the force measuring equipment is calibrated and accurate to within 0.5 N (0.1 lbf) over its entire range.

*Procedure*—Activate the adjustment mechanism and measure the force needed to pull, push, or twist.

*Pass/Fail Criteria*—The adjustment mechanism force shall conform to performance requirements of subsection 5.1.3.5 of Specification **F3021**.

*Precision and Bias*—No information is presented about either the precision or bias of test **7.1.3.5** for adjustment mechanism force since the test result is non-quantitative.

**7.1.3.6 Controlled Adjustment Mechanisms**—This test is a performance inspection of the sample to ensure that adjustment mechanisms do not free fall during adjustments.

*Apparatus and Set Up*—The sample shall be set up as described in Section **5** with the seat removed.

*Calibration*—No calibration required. Performance test only.

*Procedure*—During each adjustment, release the mechanism, i.e., let it go, at places in between adjustment slots. Record slippage of the adjustment mechanism.

*Pass/Fail Criteria*—The adjustments shall conform to the requirements of subsection 5.1.3.6 of Specification **F3021**.

*Precision and Bias*—No information is presented about either the precision or bias of test **7.1.3.6** for evaluating controlled adjustment mechanisms since the test result is non-quantitative.

**7.1.3.7 Tethered Adjustment Mechanisms**—This test is a visual and performance inspection of the sample to ensure that adjustment mechanisms are tethered and do not interfere with access to or performance of the exercise.

*Apparatus and Set Up*—The sample shall be set up as described in Section **5**.

*Calibration*—No calibration required. Visual and performance test only.

*Procedure*—Inspect all adjustments to verify that they either are tethered to the equipment or have a designated storage spot. Perform the exercise from the exercise position and verify that the tethered adjustment mechanisms do not interfere with the exercise.

*Pass/Fail Criteria*—The tethered adjustment mechanisms shall conform to the requirements of subsection 5.1.3.7 of Specification **F3021**.

*Precision and Bias*—No information is presented about either the precision or bias of test **7.1.3.7** for evaluating tethered adjustment mechanisms since the test result is non-quantitative.

**7.1.3.8 Adjustment Mechanisms—Significant Color Contrast**—Perform the color value measurement test in ~~Section **7.3**~~.

**7.1.3.9 Marked Fixed Position Settings**—This test is a visual inspection of the sample to ensure that fixed position settings/adjustments are clearly and distinctively ~~marked~~marked in an alternative format to Braille.

*Apparatus and Set Up*—The sample shall be set up as described in Section **5**.

*Calibration*—No calibration required. Visual test only.

*Procedure*—Inspect each adjustment, excluding adjustments which lock the user into position and cannot be preset before adopting the exercise position (for example, knee clamps on a lat pull down or seated leg curl) to verify that it is clearly and distinctively marked. Inspect all markings to verify that they are in a format alternative to Braille.

*Pass/Fail Criteria*—The marked fixed position settings shall conform to the requirements of subsection 5.1.3.9 of Specification **F3021**.

~~*Precision and Bias*—No information is presented about either the precision or bias of test **7.1.3.9** for measuring the marked fixed position settings shall conform to the requirements of subsection 5.1.3.9 of Specification since the test result is non-quantitative. **F3021**.~~

**7.1.3.10 Font Size and Style**—This test is a visual and dimensional inspection of the sample to ensure that any font is sans serif, non-italic font, and meets the size criteria.

*Apparatus and Set Up*—The sample shall be set up as described in Section **5**.

*Calibration*—Verify that the distance measuring equipment is calibrated and accurate to within 1 mm (0.040 in.).

*Procedure*—Inspect all font to verify that it is non-italic font and sans serif. Measure the height of the smallest letter from the top outer edge to the bottom outer edge.

*Pass/Fail Criteria*—The font size and style shall conform to the requirements of subsection 5.1.3.10 of Specification **F3021**.

*Precision and Bias*—No information is presented about either the precision or bias of test **7.1.3.10** for evaluating and measuring font size and style since the test result is non-quantitative.

**7.1.3.11 Tactile Markings**—This test is a visual and dimensional inspection and a tactile exam of the sample to ensure that markings are ~~tactile in an alternative format to Braille~~tactile.

*Apparatus and Set Up*—The sample shall be set up as described in Section **5**.

*Calibration*—Verify that the distance measuring equipment is calibrated and accurate to within 0.1 mm (0.0040 in.).

~~*Procedure*—Inspect all markings to verify that they are in a format alternative to Braille.~~ Measure the depth of the thinnest marking from top to surface.

*Pass/Fail Criteria*—The tactile markings shall conform to the requirements of subsection 5.1.3.11 of Specification **F3021**.

*Precision and Bias*—No information is presented about either the precision or bias of test **7.1.3.11** for evaluating and measuring tactile markings since the test result is non-quantitative.

**7.1.3.12 Adjustment Markings—Significant Color Contrast**—Perform the color value measurement test in ~~Section **7.3**~~.

**7.1.4 Hand Grips:**