



Designation: ~~E2023 – 10~~ **E2023 – 10 (Reapproved 2014)**

## Standard Practice for Fabrication of Neutron Radiographic Sensitivity Indicators<sup>1</sup>

This standard is issued under the fixed designation E2023; the number immediately following the designation indicates the year of original adoption or, in the case of revision, the year of last revision. A number in parentheses indicates the year of last reapproval. A superscript epsilon ( $\epsilon$ ) indicates an editorial change since the last revision or reapproval.

### 1. Scope

1.1 This practice covers the fabrication of Sensitivity Indicators (SI), which can be used to determine the relative quality of radiographic images produced by direct, thermal neutron radiographic examination.

1.2 The values stated in inch-pound units are regarded to be standard.

1.3 *This standard does not purport to address all of the safety concerns, if any, associated with its use. It is the responsibility of the user of this standard to establish appropriate safety and health practices and determine the applicability of regulatory limitations prior to use.*

### 2. Referenced Documents

2.1 *ASTM Standards:*<sup>2</sup>

[E543 Specification for Agencies Performing Nondestructive Testing](#)

[E545 Test Method for Determining Image Quality in Direct Thermal Neutron Radiographic Examination](#)

[E748 Practices for Thermal Neutron Radiography of Materials](#)

[E1316 Terminology for Nondestructive Examinations](#)

### 3. Terminology

3.1 *Definitions*—For definitions of terms used in this practice, see Terminology [E1316](#), Section H.

### 4. Summary of Practice

4.1 The Sensitivity Indicator (SI) is used for qualitative determination of the sensitivity of detail visible on the neutron radiograph. It consists of a step wedge containing gaps and holes of known dimensions. Visual inspection of the image of this device provides subjective information regarding total radiographic sensitivity with respect to the step-block material, as well as optional subjective data, regarding detrimental levels of gamma exposure.

4.2 Neutron radiography practices are discussed in Practices [E748](#). The neutron radiograph used to determine image quality using the SI shall meet the requirements of Method [E545](#).

### 5. Significance and Use

5.1 The only truly valid image quality indicator is a material or component, equivalent to the part being neutron radiographed, with a known standard discontinuity, inclusion, omission or flaw (reference standard comparison part). The SI is designed to substitute for the reference standard, providing qualitative information on hole and gap sensitivity in a single unit. Fabrication in accordance with this practice is vital for accurate and consistent measurements.

5.2 This practice shall be followed for the fabrication of all SIs to be used with Method [E545](#) to determine image quality in direct thermal neutron radiography.

### 6. Basis of Application

6.1 *Qualification of Nondestructive Agencies*—If specified in the contractual agreement, NDT agencies shall be qualified and evaluated as described in Practice [E543](#). The applicable edition of Practice [E543](#) shall be specified in the contractual agreement.

<sup>1</sup> This practice is under the jurisdiction of ASTM Committee [E07](#) on Nondestructive Testing and is the direct responsibility of Subcommittee [E07.05](#) on Radiology (Neutron) Method.

Current edition approved Jan. 1, 2014; Oct. 1, 2014. Published February 2014; November 2014. Originally approved in 1999. Last previous edition approved in 2004 as ~~E2023 – 10~~ [E2023 – 10 \(2004\)](#). DOI: ~~10.1520/E2023-10~~ [10.1520/E2023-10R14](#).

<sup>2</sup> For referenced ASTM standards, visit the ASTM website, [www.astm.org](http://www.astm.org), or contact ASTM Customer Service at [service@astm.org](mailto:service@astm.org). For *Annual Book of ASTM Standards* volume information, refer to the standard's Document Summary page on the ASTM website.

6.2 *Procedures and Techniques*—The procedures and techniques to be utilized shall be as described in this practice unless otherwise specified. Specific techniques may be specified in the contractual agreement.

6.3 *Reporting Criteria/Acceptance Criteria*—Reporting criteria for the examination results shall be in accordance with Sections 9 and 10 unless otherwise specified. Acceptance criteria, for example, reference radiographs, shall be specified in the contractual agreement.

6.4 Reexamination of repaired/reworked items is not addressed in this practice and, if required, shall be specified in the contractual document.

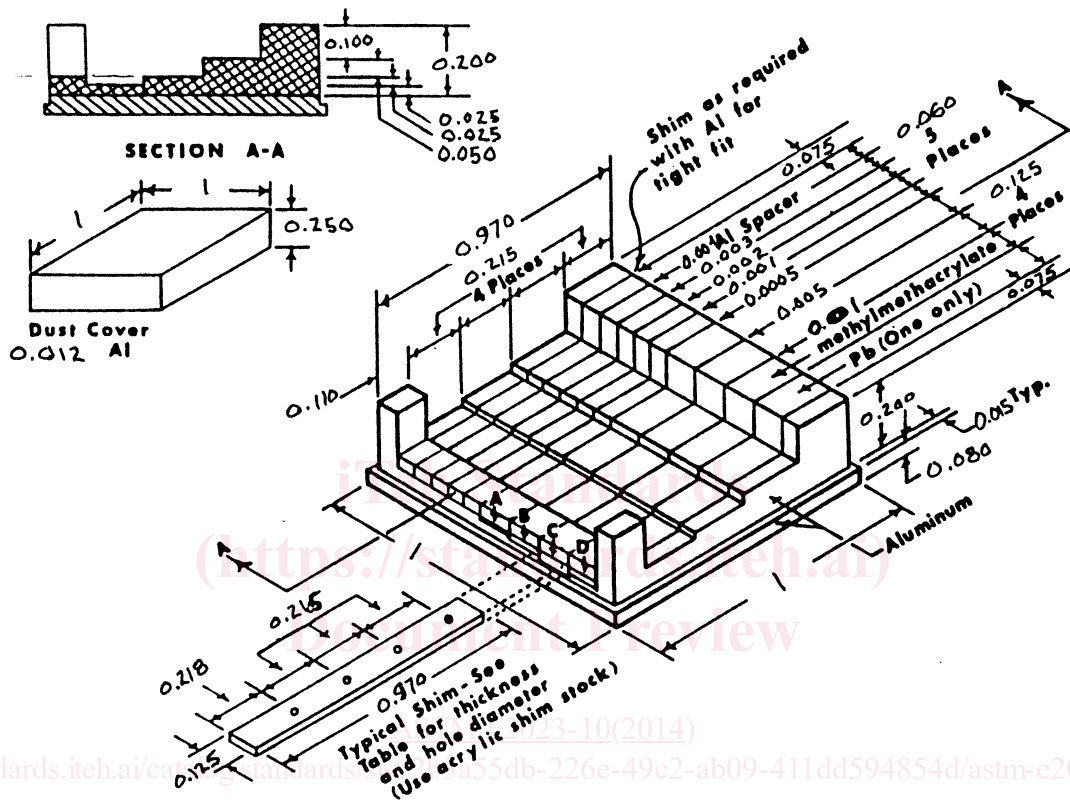

Material — Methylmethacrylate

Shim	Thickness	Hole Diameter
A	0.005	0.005
B	0.010	0.010
C	0.020	0.020
D	0.010	0.010

NOTE 1—All dimensions are in inches.

NOTE 2—The lead step may be replaced with a methylmethacrylate strip with the D shim eliminated.

FIG. 1 Sensitivity Indicator

## 7. Sensitivity Indicator (SI)

7.1 The Sensitivity Indicator (SI) shall be constructed of cast acrylic resin, lead (optional), and aluminum. The construction and dimensions are shown in Fig. 1.

7.2 The optional lead step in the SI may be replaced with a blank, cast acrylic resin step. The lead provides a visual indication of beam gamma content; however, the lead image is not used for any of the SI calculations of Method E545.

7.3 The acrylic resin shall be methylmethacrylate.

7.4 All dimensional tolerances are as noted on the figures.

7.5 Aluminum shims and strips shall be 99.9 % pure elemental material.

7.6 The SI may be encased in a 6061 aluminum dust cover, 0.012-in. thick.

7.7 When used, the optional lead shim shall be at least 99.9 % pure elemental material.

8. Fabrication<sup>3</sup>

8.1 Components:

8.1.1 Mill a Channel, 0.850-in. wide by 6.5-in. long from an aluminum block, 1-in. wide by at least 0.303-in. high by 6.5-in. long. The channel should begin 0.075-in. from edge A and leave 0.103-in. aluminum in the bottom of the channel (see Fig. 2).

8.1.2 Mill the A Channel (see Fig. 1), within this channel, 0.125-in. wide by 0.005-in. deep by 6.5-in. long. The near edge of channel A should be 0.450-in. from edge A (see Fig. 3).

8.1.3 Mill the B Channel, adjacent to the A channel, 0.125-in. wide by 0.010-in. deep by 6.5-in. long. The near edge of channel B should be 0.325-in. from edge A (see Fig. 3).

8.1.4 Mill the C Channel, adjacent to the B channel, 0.125-in. wide by 0.020-in. deep by 6.5-in. long. The near edge of channel C should be 0.200 in. from edge A (see Fig. 3).

8.1.5 Optional—Mill the D channel adjacent to the C channel, 0.125-in. wide by 0.010-in. deep by 6.5-in. long. The near edge of channel D should be 0.075-in. from edge A.

NOTE 1—The D channel is not required and shall not be milled if the lead shim is not to be used.

8.1.6 Prepare five methylmethacrylate strips, 0.060-in. thick by at least 0.200-in. wide by 6.5-in. long. These strips will be used in 8.2.11.

8.1.7 Prepare four methylmethacrylate strips, 0.125-in. thick by at least 0.200-in. wide by 6.5-in. long. One of the methylmethacrylate strips may be replaced with an optional lead strip of the same dimensions. These strips will be used in 8.2.5.

8.1.8 Prepare one strip each from aluminum shim stock, at least 0.200-in. wide by 6.5-in. long, with the following thicknesses:

- 0.0005 in.
- 0.0010 in.
- 0.0020 in.
- 0.0030 in.
- 0.0040 in.
- 0.0050 in.
- 0.0100 in.

8.1.9 Prepare one methylmethacrylate strip each to fit snugly in the 0.125-in. wide by 6.5-in. long with the following thicknesses:

ITeH Standards  
 (https://standards.iteh.ai)  
 Document Preview

<sup>3</sup> The instructions in Section 8 assume the simultaneous fabrication of five units for practical reasons. Units may be fabricated singly, if desired.

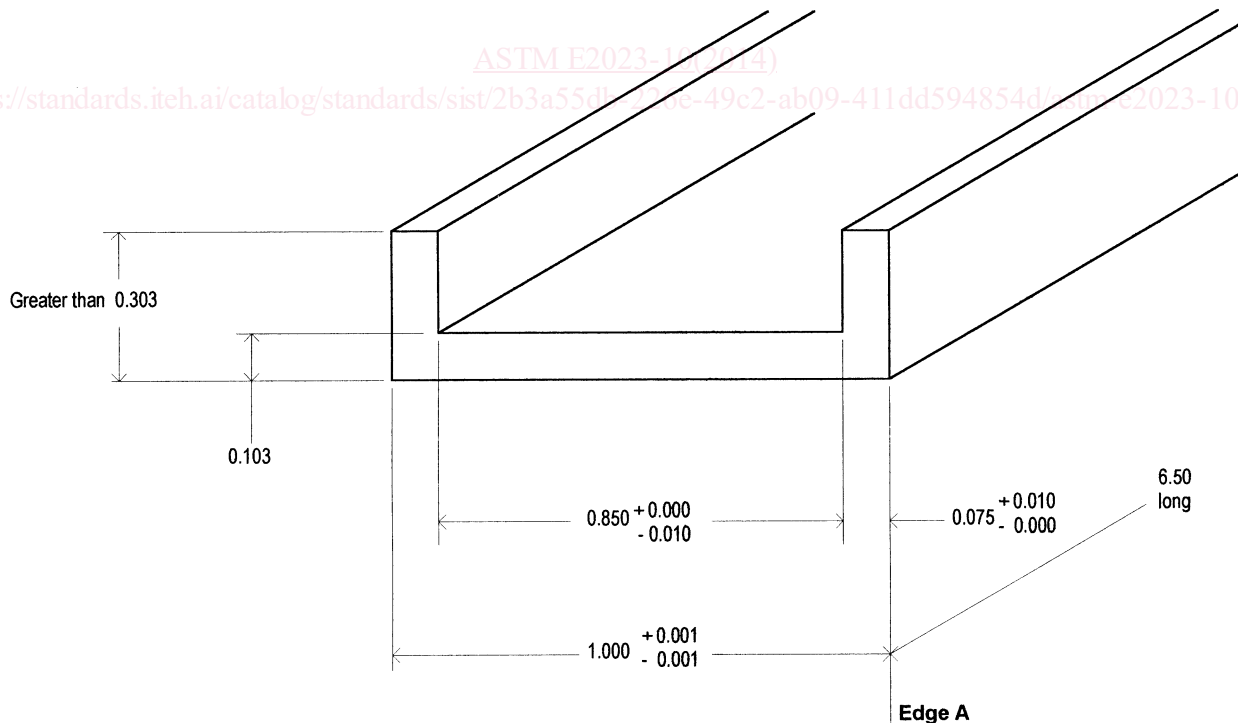

NOTE 1—Unless otherwise specified, use the following:  
 Dimensions are in inches.

Tolerances on machined dimensions: .XX = ± .01 .XXX = ± .002.

FIG. 2 Main Channel in Aluminum Block

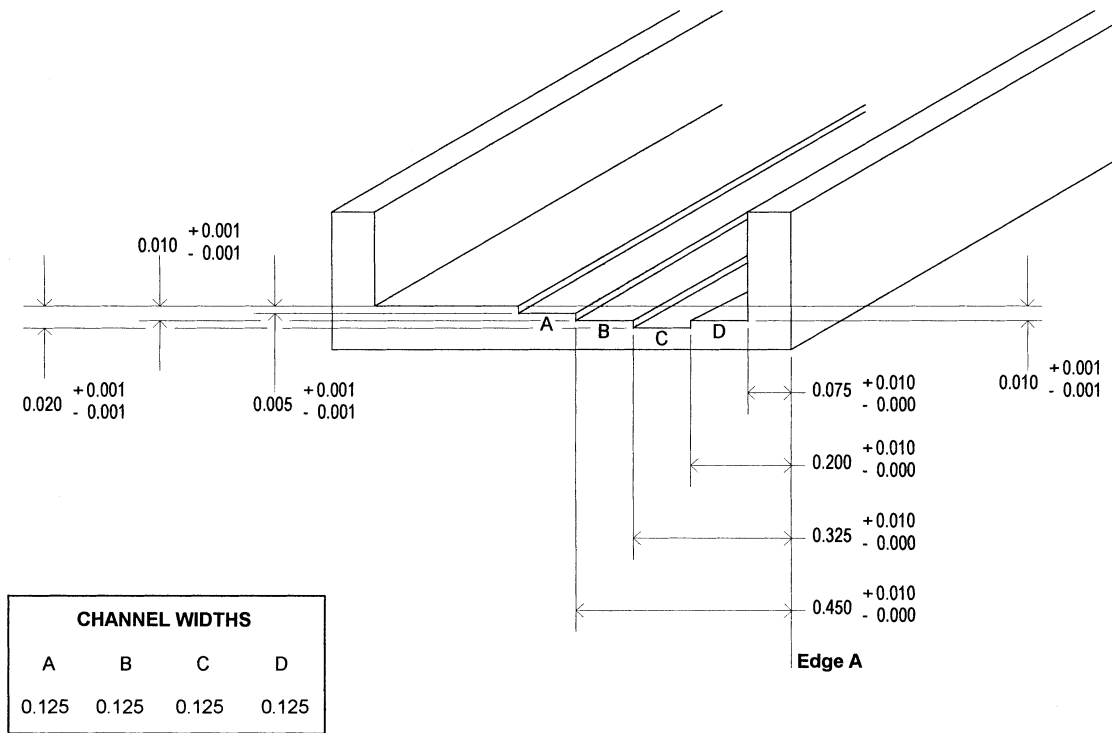

NOTE 1—Unless otherwise specified, use the following:  
Dimensions are in inches.

Tolerances on machined dimensions: .XX = ± .01 .XXX = ± .002.

FIG. 3 Channels A Through D in Main Channel

0.0050 in. (Shim A)  
0.0100 in. (Shim B)  
0.0200 in. (Shim C)  
0.0100 in. (Shim D) (If used, this strip is to be fabricated from lead stock (see Fig. 4). These strips will become Shim A through Shim D in 8.1.10.)

<https://standards.iteh.ai/catalog/standards/sist/2b3a55db-226e-49c2-ab09-411dd594854d/astm-e2023-102014>

8.1.10 Drill four holes in the shims from 8.1.9, starting 0.218 in. from one end and centering the other three holes 0.215 in. from the first hole. Repeat the process along the rest of the 6.5-in. length (see Fig. 4). The diameter of the holes are as follows:

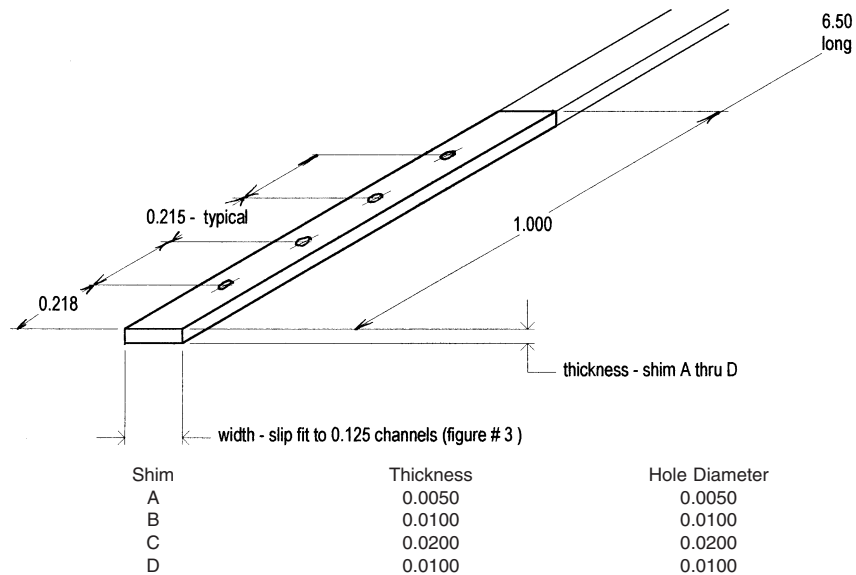

FIG. 4 Shims