



Designation: ~~D3705–86 (Reapproved 2009)~~ **D3705 – 14**

Standard Test Method for Misting Properties of Lubricating Fluids¹

This standard is issued under the fixed designation D3705; the number immediately following the designation indicates the year of original adoption or, in the case of revision, the year of last revision. A number in parentheses indicates the year of last reapproval. A superscript epsilon (ϵ) indicates an editorial change since the last revision or reapproval.

1. Scope—Scope*

1.1 This test method covers the determination of the misting characteristics of lubricating fluids.

NOTE 1—This test method should not be used to evaluate fluids containing solid additives such as graphite.

1.2 The values stated in SI units are to be regarded as standard.

1.2.1 Inch-pound units are used to describe the various tube fittings shown in Fig. 1.

1.2.2 Inch-pound thread is shown in Fig. 2.

1.3 This standard does not purport to address all of the safety concerns, if any, associated with its use. It is the responsibility of the user of this standard to establish appropriate safety and health practices and determine the applicability of regulatory limitations prior to use. For specific warning statements, see Sections 67 and 78.

2. Referenced Documents

2.1 ASTM Standards:²

[D91 Test Method for Precipitation Number of Lubricating Oils](#)

[D235 Specification for Mineral Spirits \(Petroleum Spirits\) \(Hydrocarbon Dry Cleaning Solvent\)](#)

[D4175 Terminology Relating to Petroleum, Petroleum Products, and Lubricants](#)

3. Terminology

3.1 For definitions of terms used in this test method, refer to Terminology [D4175](#).

3.2 Definitions of Terms Specific to This Standard:

3.2.1 *line condensate, n*—in a mist lubrication system, oil mist which has coalesced in the distribution lines and is not available for lubrication purposes.

3.2.2 *reclassified oil, n*—in a mist lubrication system, lubricant that has coalesced into larger droplets at the points of required lubrication.

¹ This test method is under the jurisdiction of ASTM Committee D02 on Petroleum Products—Products, Liquid Fuels, and Lubricants and is the direct responsibility of Subcommittee ~~D02.L0.02~~[D02.L0.01](#) on Machinery Lubricants (Combined into L.01) Metal Removal Fluids and Lubricants.

Current edition approved April 15, 2009 Oct. 1, 2014. Published July 2009 November 2014. Originally approved in 1978. Last previous edition approved in 2003 2009 as ~~D3705–86(2003)~~[D3705 – 86 \(2009\)](#). DOI: ~~10.1520/D3705-86R09~~[10.1520/D3705-14](#).

² For referenced ASTM standards, visit the ASTM website, www.astm.org, or contact ASTM Customer Service at service@astm.org. For *Annual Book of ASTM Standards* volume information, refer to the standard's Document Summary page on the ASTM website.

3.2.2.1 Discussion—

Mist lubrication systems are designed so that the oil mist will coalesce in the appropriate area and provide lubrication in the right place.

4. Summary of Test Method

4.1 The mist generator is charged with oil and installed in the mist system. The unit is operated for 19 h; the mist generator, line condensate bottles, and reclassified oil collector are weighed before and after the test. The output from the generator and percentages of reclassified oil, line condensate, and stray mist are determined from changes in weight.

NOTE 2—Line condensate is the commonly accepted term used to describe the oil that coalesces in the mist distribution lines. In this test, the oil that coalesces in the ~~38-mm~~[38 mm \(1½-in.\)](#) tubing and the diagonal ~~19-mm~~[19 mm \(¾-in.\)](#) tubing is collected and weighed as line condensate. Oil that coalesces in the vertical ~~19-mm~~[19 mm \(¾-in.\)](#) tubing becomes part of the reclassified oil.

*A Summary of Changes section appears at the end of this standard

5. Significance and Use

5.1 This test provides a guide for evaluating the misting characteristics of oils for use in industrial mist lubrication systems. The degree of correlation between this test and service performance has not been fully determined.

6. Apparatus

6.1 The basic system consists of the following:

6.1.1 *Oil Mist Generator*, ~~Alemite No. 383802-B4~~^{3,4} (Fig. 1, item 23) with special ASTM-ASLE mist head assembly ~~383803-B4~~ (Fig. 1, item 22). The oil mist generator is attached to the manifold so that it may be easily disconnected in order to determine its mass before and after the test.

6.1.2 *Air Temperature Regulator*, ~~Regulator~~, Alemite thermo-aire No. 383808-A4^{4,5} (Fig. 1, item 24).

6.1.3 *Mist Distribution Manifold*, as shown in Fig. 1.

6.1.4 *Mist Reclassifier Fitting*, (Fig. 1, item 15; Fig. 2). The fitting must be drilled exactly as shown in Fig. 2. Any deviations from the given hole size and pattern will negate the test.

6.1.5 *Reclassified Oil Collector*, ~~Collector and Lid~~, as shown in Fig. 3 and Fig. 4.

6.2 *Impingement Plate*, as shown in Fig. 5.

6.3 *Balance*, ~~20-kg~~ 20 kg capacity open pan, with ~~1-g~~ 1 g sensitivity.

6.4 *Air Supply*, from a source capable of maintaining an air flow rate up to 2 dm³/s. The air should be dry, oil-free, and filtered through a ~~1- μ m~~ 1 μ m filter. In order to ensure the driest and cleanest air possible, it is recommended that a drying element and filtering system such as a desiccant cartridge be added to the apparatus. The device chosen should maintain a flow rate of 14 dm³/s and provide air with a dew point not in excess of -40 °C.

NOTE 3—The oil mist generator head and mist reclassifier fitting are available from the Alemite Co. Orders should specify Special ASTM-ASLE mist head and reclassifier fitting.

NOTE 4—While not required, the addition of an oil bath temperature regulator (Alemite 383807-A4) is recommended. Results will be more consistent if the oil is kept at a constant temperature.

7. Reagents

7.1 *Stoddard Solvent*, as specified in Specification **D235** (Type 1). (**Warning**—Flammable.)

7.2 *Precipitation Naphtha*, as specified in Test Method **D91**. (**Warning**—Flammable.)

8. Preparation of Apparatus

8.1 Thorough cleaning of the apparatus with solvent is required prior to initiating a test on a new oil. For a duplicate test on the same oil, the mist generator should be thoroughly drained but the apparatus need not be cleaned with solvent.

8.2 Drain the oil thoroughly and rinse the generator with Stoddard solvent. (**Warning**—Combustible. Vapor harmful.)⁴

8.3 Charge the generator with 2 L of clean Stoddard solvent and mist the Stoddard solvent through the manifold for 30 min. (**Warning**—Do not use the air heater while misting the Stoddard solvent.)

8.4 Drain the Stoddard solvent from the generator, rinse the generator with naphtha, and blow dry with compressed air. (**Warning**—Extremely flammable. Harmful if inhaled. Vapors may cause flash fire.)

8.5 Disconnect the mist head and remove the oil adjustment screw; rinse the head and screw with naphtha and blow dry.

8.6 Remove the reclassifier fitting and rinse it with naphtha; examine the orifices for deposits or buildup. If necessary, the orifices may be cleaned with a fine pipe cleaner.

9. Procedure

9.1 *Break-In Period*:

9.1.1 Charge the mist generator with 44 L \pm 0.1 L of test oil. Assemble the test apparatus.

9.1.2 Turn the oil flow adjusting screw clockwise to a fully closed position and then open the screw by turning it counterclockwise to a full open position.

9.1.3 Open the air regulator until a pressure of ~~37 millibars (37 kPa)~~ 3.7 kPa is obtained on the manifold ~~gauge~~ gauge (Fig. 1, item 25).

9.1.4 Activate the oil heater and inlet air heater and adjust both to ~~40~~ 40 °C \pm ~~1°C~~ 1 °C.

³ The sole source of supply of ~~Alemite No. 383802-B4~~ known to the committee at this time is Alemite Co., Stewart Warner, 1826 West Diversey Parkway, Chicago, IL 60614.

⁴ If you are aware of alternative suppliers, please provide this information to ASTM International Headquarters. Your comments will receive careful consideration at a meeting of the responsible technical committee¹, which you may attend.

⁵ The sole source of supply of Alemite thermo-aire unit No. 383808-A4 known to the committee at this time is Alemite Co., Stewart Warner, 1826 West Diversey Parkway, Chicago, IL 60614.

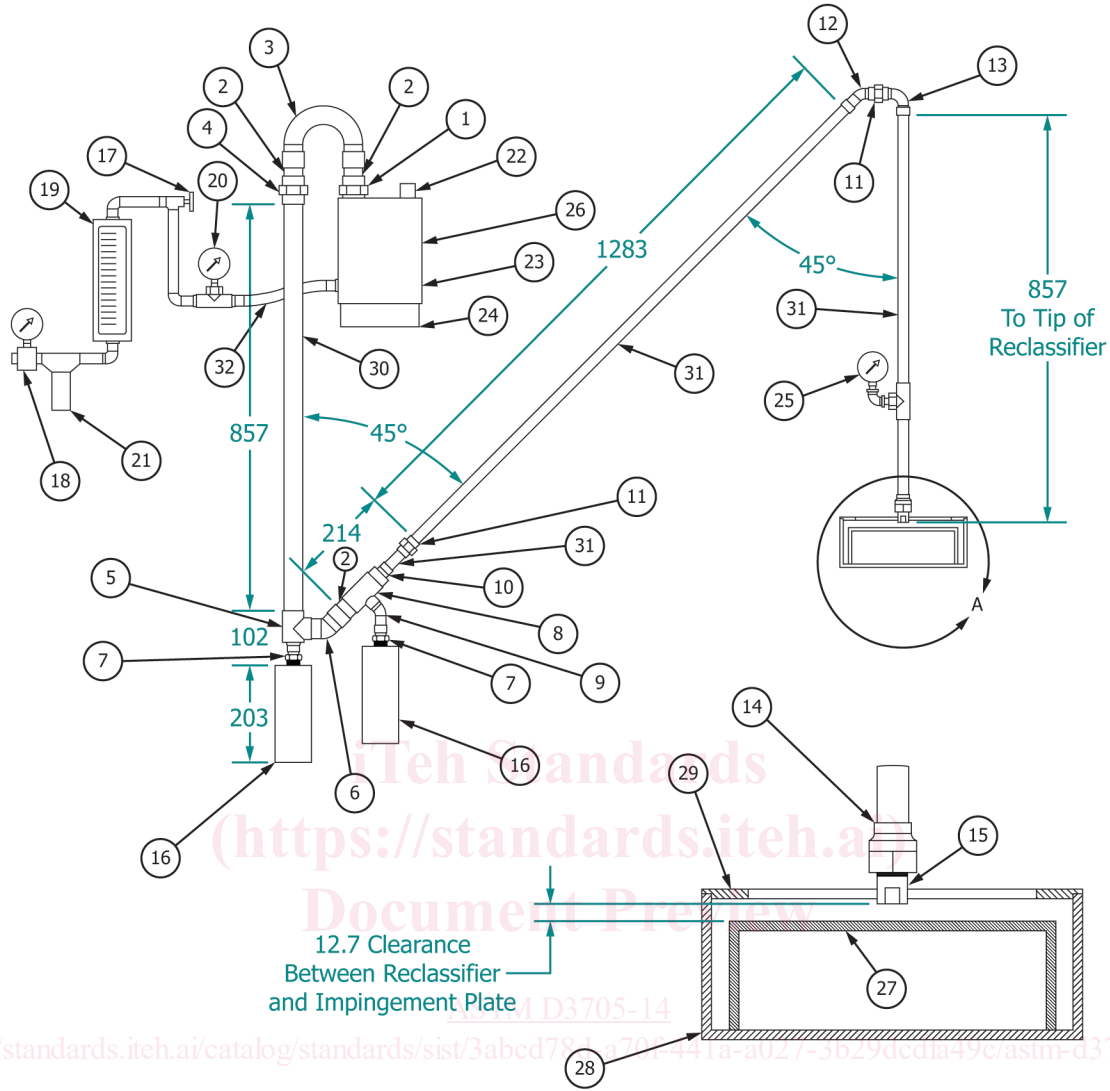

Detail A

MIST-MANIFOLD

Proposed ASTM Bill of Materials

- (1) 1½ C x 1½ in. MPT union
- (1) 1½ C x 1½ in. MPT union
- (2) 1½ in. Copper tubing, 3 in. Long
- (2) 1½ in. copper tubing, 3 in. long
- (3) 1½ in. C x C Return bend
- (3) 1½ in. C x C Return bend
- (4) 1½ in. C Union
- (4) 1½ in. C Union
- (5) 1½ x ¾ x 1½ in. C x C x C tee
- (5) 1½ x ¾ x 1½ in. C x C x C tee
- (6) 1½ in. C 45 deg Fig. ell (straight ell)
- (6) 1½ in. C 45 deg fig Ell (straight ell)
- (7) ¾ in. Fig x MPT adapter
- (7) ¾ in. fig x MPT adapter
- (8) 1½ x 1½ x ¾ in. C x C x C tee
- (8) 1½ x 1½ x ¾ in. C x C x C tee
- (9) ¾ in. C 45 deg Fig. ell
- (9) ¾ in. C 45 deg fig ell
- (10) 1½ in. Fig. x ¾ in. C extended bushing
- (10) 1½ ftg x ¾ in. C extended bushing
- (11) ¾ in. C Union
- (11) ¾ in. C Union

- (12) ¾ in. Fig x C 45 deg Fig. ell
- (13) ¾ in. Fig x C 90 deg Fig ell
- (14) ¾ C x ½ in. F adapter
- (19) Air flow meter (L/s)
- (15) ½ in. Reclassifier fitting 12 holes
- (20) Pressure gage, 7 kPa
- (16) Collector bottles
- (21) Air filter
- (17) Thermometer
- (22) Oil mist head assembly with adjusting screw
- (18) Pressure regulator with gage
- (23) Oil mist generator
- (19) Flow meter
- (24) Thermo-aire unit
- (20) Pressure gage
- (25) Pressure gage, 4 kPa
- (21) Air filter
- (26) Thermocouple
- (22) Oil mist head assembly special ASTM-ASLE
- (27) Impingement plate
- (23) Oil mist generator
- (28) Collection box
- (24) Thermo-aire unit
- (29) Lid for collection box

- | | |
|--|---|
| (12) 3/4 in. ftg x C 45 deg ftg ell | (30) 1 1/2 in. type "M" hard copper tubing, 41.3 mm O.D. x 38.3 mm I.D. |
| (13) 3/4 in. ftg x C 90 deg ftg ell | (31) 3/4 in. type "K" hard copper tubing, 22.2 mm O.D. x 18.9 mm. I.D. |
| (14) 3/4 C x 1/2 in. FPT adapter | (32) Flexible hose |
| (15) 1/2 in. reclassifier fitting | |
| (16) Collector bottle, 1 L plastic with 3/4 female NPT top | |
| (17) Thermometer | |
| (18) Pressure regulator with gage (2 mPa) | |

FIG. 1 Mist Test Apparatus Distribution Manifold

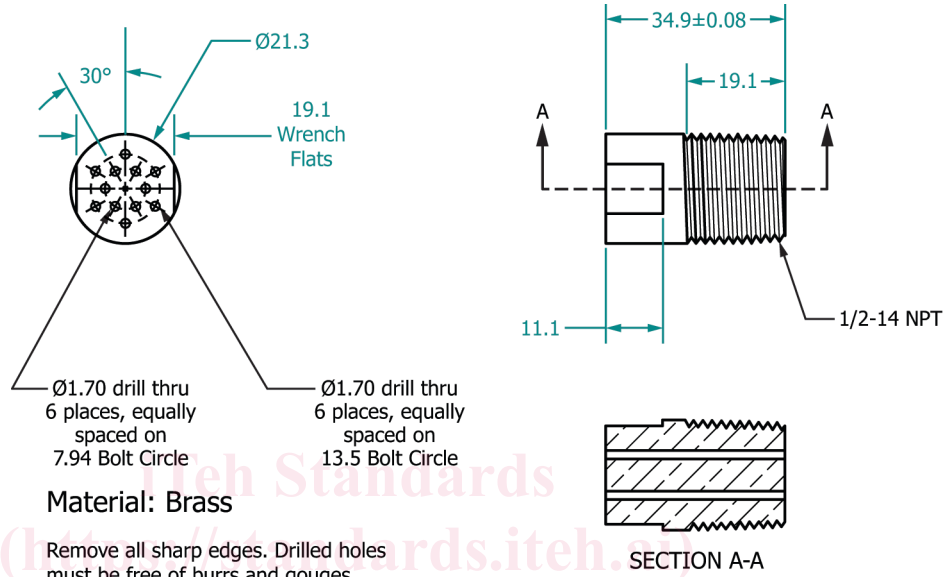

FIG. 2 Mist Reclassifier Fitting

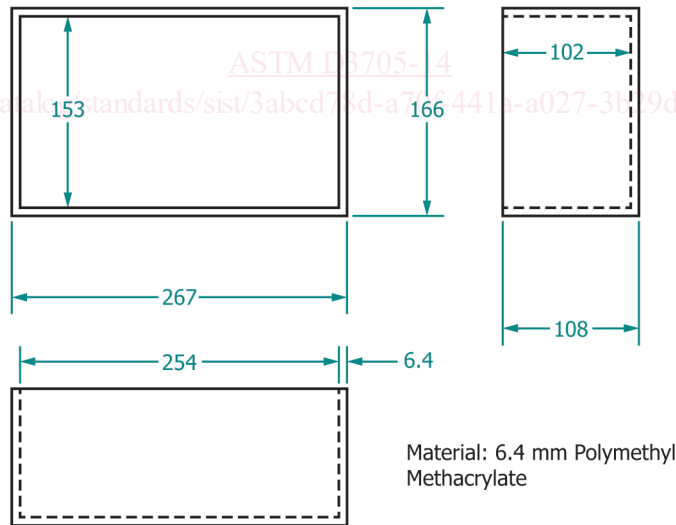

FIG. 3 Reclassified Oil Collector

9.1.5 Allow the unit to run for 1 h to stabilize.

NOTE 5—The full open position for the oil flow adjusting screw, that is, the position beyond which further opening of the adjusting screw does not increase oil output from the mist generator, should be determined for each mist test unit. The full open position on most test units is attained by turning the adjusting screw counterclockwise 2-1/2 turns from the fully closed position.

9.2 Test Start-Up:

9.2.1 Following the 1-h-1-h break-in, deactivate the air and oil heaters and turn off the air supply.