



Designation: **F2716–08 F2716 – 08 (Reapproved 2014)**

Standard Practice for Comparison of Nonmetallic Flat Gaskets in High Pressure Saturated Steam¹

This standard is issued under the fixed designation F2716; the number immediately following the designation indicates the year of original adoption or, in the case of revision, the year of last revision. A number in parentheses indicates the year of last reapproval. A superscript epsilon (ϵ) indicates an editorial change since the last revision or reapproval.

1. Scope

1.1 This practice provides a means of comparing various nonmetallic flat gasket materials, Classification **F104**, in saturated steam service under controlled conditions. While the practice is designed primarily for flat gaskets, it also can be applied to various form-in-place gasket materials upon modification. The practice may be used for quality control or material comparison purposes as agreed upon between producer and user. This practice is consistent with Fluid Sealing Association test method, FSA-NMG-204-02, with regard to fixtures used and procedure.

1.2 The values stated in inch-pound units are to be regarded as standard. The values given in parentheses are mathematical conversions to SI units that are provided for information only and are not considered standard.

1.3 *This standard does not purport to address all of the safety concerns, if any, associated with its use. It is the responsibility of the user of this standard to establish appropriate safety and health practices and determine the applicability of regulatory limitations prior to use.*

2. Referenced Documents

2.1 ASTM Standards:²

A193/A193M Specification for Alloy-Steel and Stainless Steel Bolting for High Temperature or High Pressure Service and Other Special Purpose Applications

A194/A194M Specification for Carbon and Alloy Steel Nuts for Bolts for High Pressure or High Temperature Service, or Both **F104** Classification System for Nonmetallic Gasket Materials

2.2 ASME Standards:³

ASME B16.21 Nonmetallic Flat Gaskets for Pipe Flanges

ASME PCC-1 Guidelines for Pressure Boundary Bolted Flange Joint Assembly

2.3 ESA/FSA Standards:⁴

ESA/FSA Publication No. 009/98 Guidelines for Safe Seal Usage - Flanges and Gaskets

FSA-NMG-204-02 Standard Test Method for Performance of Non-Asbestos Gaskets in High Pressure, Saturated Steam

3. Significance and Use

3.1 This practice may be used to evaluate Classification **F104** gasket materials using saturated steam and standard ASME RF (raised face) flanges. This practice is intended for use as quality control or material comparison tool and should not be used to predict performance.

4. Apparatus

4.1 The test equipment shall consist of the following components:

4.1.1 *Hot Air Circulating Oven*, equipped with temperature controls and capable of maintaining temperatures up to $570 \pm 5^\circ\text{F}$ ($299 \pm 3^\circ\text{C}$).

4.1.2 *Scales*, capable of maintaining an accuracy of ± 0.1 g with a nominal capacity of 12 kg.

¹ This practice is under the jurisdiction of ASTM Committee **F03** on Gaskets and is the direct responsibility of Subcommittee **F03.10** on Composite Gaskets. Current edition approved May 1, 2008 July 1, 2014. Published May 2008 November 2014. Originally approved in 2008. Last previous edition approved in 2008 as F2716 – 08. DOI: 10.1520/F2716-08-10.1520/F2716-08R14.

² For referenced ASTM standards, visit the ASTM website, www.astm.org, or contact ASTM Customer Service at service@astm.org. For *Annual Book of ASTM Standards* volume information, refer to the standard's Document Summary page on the ASTM website.

³ Available from American Society of Mechanical Engineers (ASME), ASME International Headquarters, Three Park Ave., New York, NY 10016-5990, <http://www.asme.org>.

⁴ Available from Fluid Sealing Association (FSA), 994 Old Eagle School Road, Suite 1019, Wayne, PA 19087-1866.

4.1.3 *Flange Fixture*—A2 in. cast steel Class 600 fixture made from one weld neck flange capped by welding to boiler code and one blind flange (see Fig. 1). Flange surfaces are 275 to 325 RMS $\mu\text{in.}$ (7.0 to 8.3 μm), flatness range 0.002 in. (0.05 mm). Each fixture shall have an identification number.

4.1.4 *Flange Protectors*—To help ensure safe operation, use standard metal flange protectors.

4.1.5 *Fasteners:*

4.1.5.1 Seven $\frac{5}{8}$ -in. bolts, 4 in. long, per Specification A193/A193M, Grade B7.

4.1.5.2 One calibrated bolt modified by the insertion of a calibration pin as detailed in Fig. 1.

4.1.5.3 Eight $\frac{5}{8}$ -in. hexagonal nuts per Specification A194/A194M, Grade 4, coarse thread.

4.1.5.4 Sixteen $\frac{5}{8}$ -in. hardened steel washers (38-45 HRC), Grade 8.

4.1.6 *Calibrated Dial Indicator*, graduated to 0.0001 in. (0.0025 mm) and equipped with a 90° conical contact point to be used in conjunction with the adapter shown in Fig. 1.

4.1.7 *Torque Wrench*—One calibrated torque wrench with a minimum capacity of 70 ft-lbf (95 N·m).

4.1.8 *Torque Wrench*—One calibrated torque wrench with a range of 0 to 200 in.-lbf (0 to 23 N·m).

4.1.9 *Bolt Lubricant*—High temperature-resistant molybdenum disulfide grease.

4.2 *Preparation of Apparatus:*

4.2.1 Prior to running any tests in a new fixture, the integrity of the assembled test fixture should be checked by running a test at a temperature at least 100°F (38°C) higher than the test temperature, without exceeding the temperature/pressure rating for the flange. A standard gasket material approved for these service conditions shall be used with water as the test fluid.

4.2.2 The maximum use temperature for the fixture with saturated steam is 563°F (295°C). Therefore, if a test temperature is not specified, this maximum shall be used as the default. However, any temperature that does not exceed this limit may be used if agreed upon by the producer and user.

4.2.3 Follow the steps in Section 9 for one cycle of a minimum of 24 h. Ensure that the gasket is acceptable for that temperature/pressure.

5. Test Specimen

5.1 The test specimen shall be a Class 600 2-in. (50-mm) ring gasket. It is recommended that a $\frac{1}{16}$ -in. (1.5-mm) thick gasket be used. However, other thicknesses can be used if agreed to by the producer and user.

5.1.1 See ASME B16.21, Table 8, for gasket dimensions.

5.1.2 See Classification F104 for thickness tolerance.

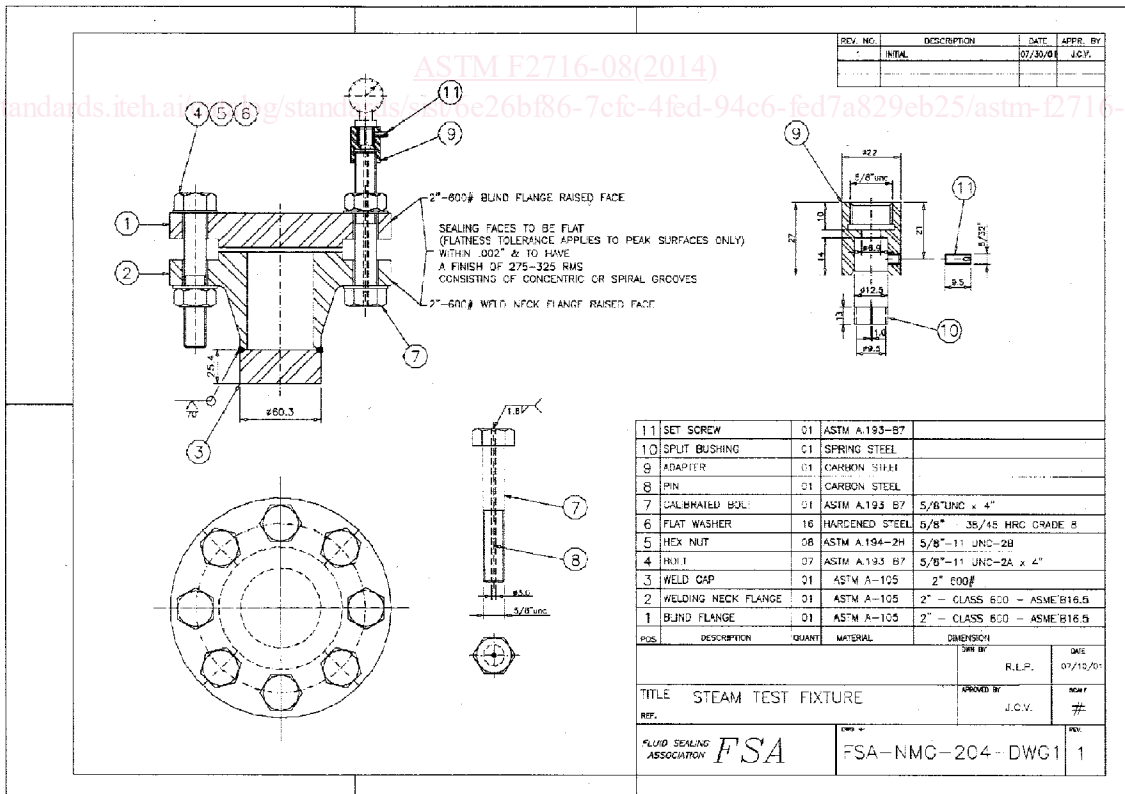

FIG. 1 FSA Steam Test Fixture

5.1.3 Preconditioning of the test gasket is not necessary, since this test is designed for shelf stock gaskets.

6. Flange Limits

6.1 Ensure that the test pressure never exceeds the pressure/temperature rating of the flange class:

@ 400°F (205°C)
@ 500°F (260°C)
@ 600°F (316°C)
@ 700°F (371°C)

Class 600 Cast Steel
Limited to 1270 psig (88.6 bar) or (8.87 MPa)
Limited to 1200 psig (83.8 bar) or (8.38 MPa)
Limited to 1095 psig (76.6 bar) or (7.66 MPa)
Limited to 1065 psig (74.5 bar) or (7.45 MPa)

7. Test Limits

7.1 Temperature/pressure properties for saturated steam from the steam table:

iTeh Standards
(<https://standards.iteh.ai>)
Document Preview

[ASTM F2716-08\(2014\)](https://standards.iteh.ai/catalog/standards/sist/6e26bf86-7cfc-4fed-94c6-fed7a829eb25/astm-f2716-082014)

<https://standards.iteh.ai/catalog/standards/sist/6e26bf86-7cfc-4fed-94c6-fed7a829eb25/astm-f2716-082014>



400°F (205°C)
450°F (232°C)
500°F (260°C)
540°F (282°C)
550°F (288°C)
563°F (295°C)

Generates 235 psig (16.2 bar) or (1.62 MPa)
Generates 405 psig (27.9 bar) or (2.79 MPa)
Generates 665 psig (45.8 bar) or (4.58 MPa)
Generates 945 psig (65.1 bar) or (6.51 MPa)
Generates 1035 psig (71.3 bar) or (7.13 MPa)
Generates 1145 psig (78.9 bar) or (7.89 MPa)

8. Bolt Torque Guidelines

8.1 The recommended assembly torque is 65 ± 5 ft·lbf (88 ± 7 N·m), which produces a gasket stress of approximately 11 000 psi (75.8 MPa). This calculation is based on the use of molybdenum disulfide grease as the bolt lubricant (4.1.9).

8.2 A recommended article is “Torque - Tensioning Part II” by Dr. H. E. Trucks.⁵ Also see ASME PCC-1.

8.3 Various assembly torques may be used, as agreed upon by producer and user, and provided the gasket stress is never less than 4350 psi (30 MPa).

9. Procedure

9.1 A minimum of two test assemblies is recommended per gasket type tested.

9.2 Ensure that the flange assembly has been thoroughly cleaned and that the exposed surfaces of the flanges are free of all residues from previous tests. Inspect for nicks, scratches, or serious defects. Recondition when required. (**Warning**—It is important to check the flanges to ensure that the surfaces remain within the correct roughness and flatness range.)

9.3 Ensure that the bolts, nuts, and washers are not damaged and that the nut runs freely onto the bolt by hand.

9.4 Cut standard ASME 2-in., Class 600 ring gaskets.

9.5 Clean bolt threads, nuts, and washers with an organic solvent. Then lubricate bolts, nuts, and washers. Do not lubricate the dial indicator adapter assembly or the part of the calibrated bolt that it will contact, since the presence of lubricants on these components will adversely affect bolt elongation readings. Do not coat gasket or flanges with any kind of release material.

9.6 Assemble the fixture as follows:

9.6.1 Place the empty weld neck flange on the scale and tare it.

9.6.2 Pour 125 mL of water in the flange, and record the exact weight of water (W_w).

9.6.3 Tare the scale, center the gasket onto the raised face of the weld neck flange, and record gasket weight (G_w).

9.6.4 Place the blind flange carefully on the weld neck flange, and install the bolts, washers, and nuts finger tight.

9.6.5 Install the dial indicator assembly (dial indicator mounted on adapter) over the calibrated bolt with a calibrated torque wrench set to 40 in·lbf (4.6 N·m), and zero the dial. Lock the dial indicator in the zero position, then remove the dial indicator assembly carefully. Bolt stretch may also be measured externally using an ultrasonic bolt stretch gauge for a given bolt.

9.6.6 Using a calibrated torque wrench, torque the bolt according to the FSA recommended cross pattern in 3 increments of 20 ± 5 ft·lbf (27 ± 7 N·m) and finally one cycle at 65 ± 5 ft·lbf (88 ± 7 N·m) (see ESA/FSA Publication No. 009/98 or ASME PCC-1, or both). Then torque each bolt consecutively in a counterclockwise pattern at 65 ft·lbf (88 N·m), doing the first bolt a second time. The final torque may be adjusted as agreed upon between producer and user, but must be clearly stated in the report. The default torque setting shall be 65 ft·lbf (88 N·m) unless otherwise agreed upon and specified.

9.6.7 Complete the tightening process in 15 min.

9.6.8 Ten minutes after completing the tightening process described in 9.6.6, torque again with the FSA cross pattern to 65 ft·lbf (88 N·m). Finally, tighten each bolt consecutively in a counterclockwise pattern to 65 ft·lbf (88 N·m), doing the first bolt a second time.

9.6.9 Reinstall the dial indicator assembly over the calibrated bolt using a calibrated torque wrench set to 40 in·lbf (4.6 N·m). Take the reading and record this value as L_o . Remove the dial indicator assembly carefully. This reading may also be taken using an external bolt stretch gauge as described in 9.6.5.

9.6.10 Install the flange protector, weigh the assembly, and record the weight as W_r .

9.6.10.1 A separate dial indicator assembly (dial indicator mounted on adapter) will be required for each calibrated bolt used in the test.

9.7 Place the test rigs in the oven, and raise the temperature so the test temperature is reached no sooner than in 30 min. Ideally, a temperature rate-of-rise of 1°C/min is preferred.

NOTE 1—The test can be run with the steam in contact with the gasket by locating the fixture in the oven with the liquid chamber down (steam phase). Another option is to allow the gasket to be in contact with the test liquid by reversing the fixture so the liquid chamber will be up (wet phase).

NOTE 2—The weekly steam cycle in Fig. 2 consists of two cycles allowing time for the technician to take all the measurements in a normal 5-day working week.

9.8 After the indicated time at the chosen temperature, cool down the oven to room temperature no sooner than 30 min. Ideally, a cool down rate of 1°C/min is preferred.

⁵ Trucks, Dr. H. E., “Torque-Tensioning Part II,” *Fastener Technology*, December 1987.