



Designation: **D665—12 D665 – 14**



Designation: **135/06**

Standard Test Method for Rust-Preventing Characteristics of Inhibited Mineral Oil in the Presence of Water¹

This standard is issued under the fixed designation D665; the number immediately following the designation indicates the year of original adoption or, in the case of revision, the year of last revision. A number in parentheses indicates the year of last reappraisal. A superscript epsilon (ϵ) indicates an editorial change since the last revision or reappraisal.

This standard has been approved for use by agencies of the U.S. Department of Defense.

1. Scope*

1.1 This test method covers the evaluation of the ability of inhibited mineral oils, particularly steam-turbine oils, to aid in preventing the rusting of ferrous parts should water become mixed with the oil. This test method is also used for testing other oils, such as hydraulic oils and circulating oils. Provision is made in the procedure for testing heavier-than-water fluids.

NOTE 1—For synthetic fluids, such as phosphate ester types, the plastic holder and beaker cover should be made of a chemically resistant material, such as polytetrafluoroethylene (PTFE); chemically resistant material suitable for the type of fluid tested.

1.2 The values stated in SI units are to be regarded as standard. No other units of measurement are included in this standard.

1.3 *This standard does not purport to address all of the safety concerns, if any, associated with its use. It is the responsibility of the user of this standard to establish appropriate safety and health practices and determine the applicability of regulatory limitations prior to use.* For specific warning statements, see [6-47.4 – 6-67.6](#).

2. Referenced Documents

2.1 ASTM Standards:²

[A108 Specification for Steel Bar, Carbon and Alloy, Cold-Finished](#)

[A240/A240M Specification for Chromium and Chromium-Nickel Stainless Steel Plate, Sheet, and Strip for Pressure Vessels and for General Applications](#)

[D91 Test Method for Precipitation Number of Lubricating Oils](#)

[D1193 Specification for Reagent Water](#)

[D2422 Classification of Industrial Fluid Lubricants by Viscosity System](#)

[D3603 Test Method for Rust-Preventing Characteristics of Steam Turbine Oil in the Presence of Water \(Horizontal Disk Method\)](#)

[D4057 Practice for Manual Sampling of Petroleum and Petroleum Products](#)

[E1 Specification for ASTM Liquid-in-Glass Thermometers](#)

2.2 Other Documents:

[Motor Fuels, Section I, Annex A2, Table 32, Reference Materials and Blending Accessories³](#)

[Specifications-IP Standard Thermometers, Vol 2, Appendix A⁴](#)

[Specifications for IP Standard Reference Liquids, Appendix B⁴](#)

[SAE Standard J405 Chemical Composition of SAE Wrought Stainless Steels⁵](#)

[BS 871 Specification for abrasive papers and cloths⁴](#)

¹ This test method is under the jurisdiction of ASTM Committee D02 on Petroleum Products—Products, Liquid Fuels, and Lubricants and is the direct responsibility of Subcommittee D02.C0.02 on Corrosion and Water/Air Separability.

Current edition approved Nov. 1, 2012/Oct. 1, 2014. Published March 2013/November 2014. Originally approved in 1942. Last previous edition approved in 2006/2012 as [D665/D665 – 12 – 06](#). DOI: [10.1520/D0665-12.10.1520/D0665-14](#).

This standard has been developed through the cooperative effort between ASTM International and the Energy Institute, London. The EI and ASTM International logos imply that the ASTM International and EI standards are technically equivalent, but does not imply that both standards are editorially identical.

² For referenced ASTM standards, visit the ASTM website, [www.astm.org](#), or contact ASTM Customer Service at [service@astm.org](#). For *Annual Book of ASTM Standards* volume information, refer to the standard's Document Summary page on the ASTM website.

³ See 1996 *Annual Book of ASTM Standards*, Vol 05.04.

⁴ *Annual Book of IP Standard Methods for Analysis and Testing of Petroleum and Related Products*, Vol 2. Available from Energy Institute, 61 New Cavendish St., London, WIG 7AR, U.K.

⁵ 1995 *SAE Handbook*, Vol 1. Available from Society of Automotive Engineers (SAE), 400 Commonwealth Dr., Warrendale, PA 15096-0001.

*A Summary of Changes section appears at the end of this standard

3. Terminology

3.1 Definitions of Terms Specific to This Standard:

3.1.1 *rust, n*—a special case of corrosion that can be visually observed on the surface of round steel test rods as reddish-brown discoloration or small black spots.

4. Summary of Test Method

4.1 A mixture of 300 mL of the oil under test is stirred with 30 mL of distilled water or synthetic sea water, as required, at a temperature of $60\text{ }^{\circ}\text{C} \pm 1^{\circ}\text{C}$ with a cylindrical steel test rod completely immersed therein. It is recommended to run the test for 4 h; however, the test period may, at the discretion of the contracting parties, be for a shorter or longer period. The test rod is observed for signs of rusting and, if desired, degree of rusting.

NOTE 2—Until 1999 it was customary to run the test for 24 h. A round robin with comparisons of different test times showed that no statistically significant differences in rating were found for any sample, between the 4 h and 24 h results.⁶

5. Significance and Use

5.1 In many instances, such as in the gears of a steam turbine, water can become mixed with the lubricant, and rusting of ferrous parts can occur. This test indicates how well inhibited mineral oils aid in preventing this type of rusting. This test method is also used for testing hydraulic and circulating oils, including heavier-than-water fluids. It is used for specification of new oils and monitoring of in-service oils.

NOTE 3—This test method was used as a basis for Test Method D3603. Test Method D3603 is used to test the oil on separate horizontal and vertical test rod surfaces, and can provide a more discriminating evaluation.

6. Apparatus

6.1 *Oil Bath*—A thermostatically controlled liquid bath capable of maintaining the test sample at a temperature of $60\text{ }^{\circ}\text{C} \pm 1^{\circ}\text{C}$ (see Note 4). An oil having a viscosity of approximately ISO VG 32 (see Classification D2422) is suitable for the bath. The bath shall have a cover with holes to accommodate the test beakers.

NOTE 4—ASTM Thermometer 9C, as prescribed in Specification E1, or IP Thermometer 21C in accordance with IP Standard Thermometers, Volume 2, Appendix A, is suitable to indicate the temperature. Alternatively, calibrated thermocouples may be used.

6.2 *Beaker*—A ~~400-mL~~, Berzelius-type, tall-form heat-resistant glass beaker without ~~pour-out~~, pour-out, as shown in Fig. 1, approximately 127 mm in height measured from the inside bottom center and approximately ~~70 mm~~ 70 mm inside diameter measured at the middle.

6.3 *Beaker Cover*—A flat beaker cover of glass or poly (methyl methacrylate) (PMMA) (Note 5), kept in position by suitable means such as a rim or groove. Two holes shall be provided on any diameter of the cover; one for a stirrer 12 mm in diameter with its center 6.4 mm from the center of the cover; and the other, on the opposite side of the center of the cover, for the test rod assembly (see Section 89), 18 mm in diameter with its center 16 mm from the center of the cover. In addition, a third hole 12 mm in diameter shall be provided for a temperature measuring device, with its center 22.5 mm from the center of the cover and on a diameter of the cover at right angles to the diameter through the other two holes.

NOTE 5—An inverted petri dish makes a suitable cover, as the sides of the dish aid in keeping it in position. Fig. 2 shows a PMMA resin cover for the beaker which has been found to be suitable. An optional feature is shown, consisting of a slot, 1.6 mm by 27 mm, which is centered on a diameter of the stirrer hole at right angles to the cover diameter through the test rod hole and stirrer hole. This feature allows withdrawal of the stirrer while the beaker cover is in place. When the test method test is used for other fluids such as synthetics, the beaker cover should be made from chemically resistant material such as polychlorotrifluoroethylene (PCTFE).

6.4 The plastic holder shall be made of PMMA resin in accordance with the dimensions shown in Fig. 3 (two types of holders are illustrated). When testing synthetic fluids, the plastic holder should be made from chemically resistant material such as polytetrafluoroethylene (PTFE).

6.5 *Stirrer*—A stirrer constructed entirely from stainless steel (Note 6 and Note 7) in the form of an inverted T. A flat blade ~~25~~ 25 by ~~6~~ 6 mm by 0.6 mm shall be attached to a ~~6-mm rod~~ rod with a diameter of 6 mm in such a way that the blade is symmetrical with the rod and has its flat surface in the vertical plane.

NOTE 6—A suitable material is an 18 % chromium, 8 % nickel alloy steel conforming to Type 304, of Specification A240/A240M, or SAE No. 30304 (see SAE J405), or BS 970: Part 1: 1983: 302S31.

NOTE 7—If stainless steel is not obtainable, stirrers made of heat-resistant glass and having approximately the same dimensions as the stainless steel stirrers specified can be used.

⁶ Supporting data (results of the cooperative test program with modified test duration) have been filed at ASTM International Headquarters and may be obtained by requesting Research Report RR:D02-1474.

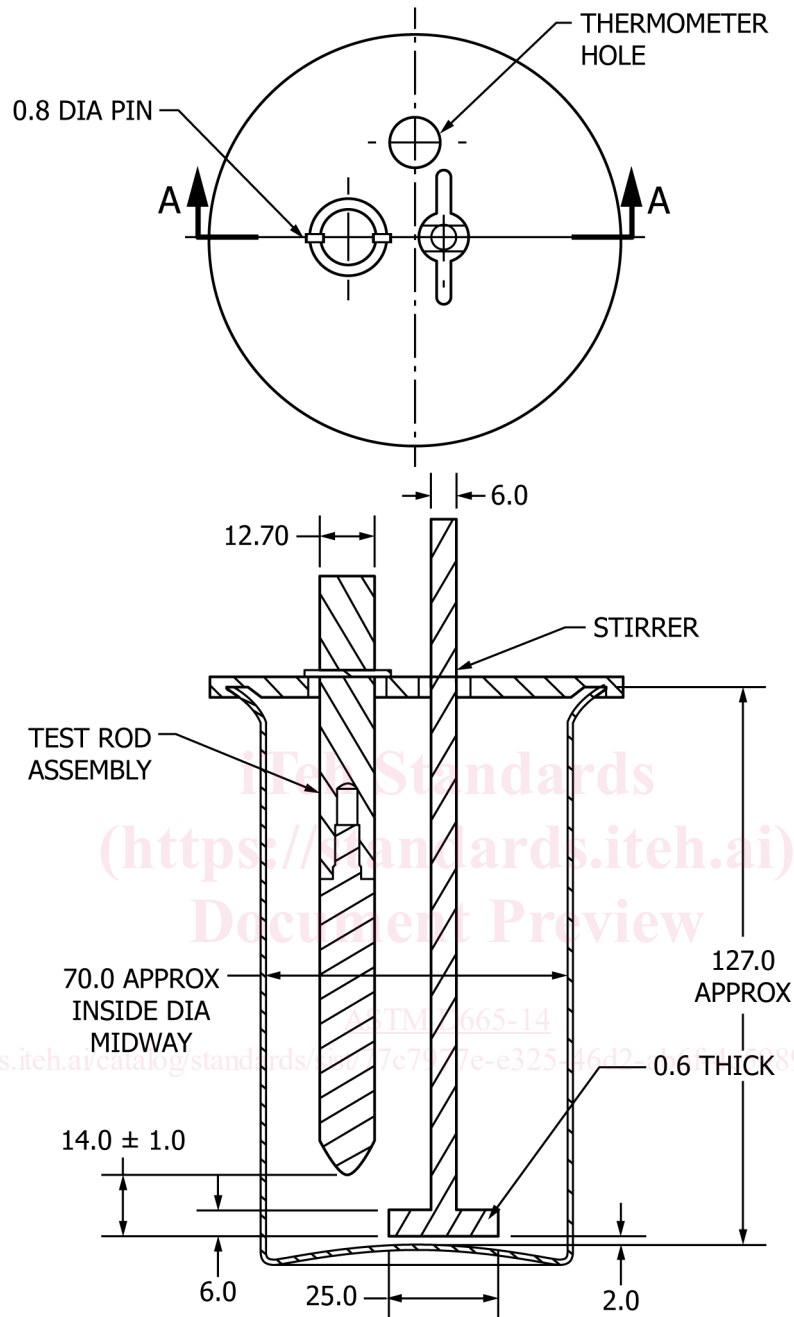

Note - All units are in millimeters, unless otherwise specified.
Tolerances for all dimensions are $\pm 10\%$ unless otherwise noted.

FIG. 1 Rusting Test Apparatus

6.6 *Stirring Apparatus*—Any convenient form of stirring apparatus capable of maintaining a speed of $1000 \text{ r/min} \pm 50 \text{ r/min}$.

6.7 *Grinding and Polishing Equipment—Equipment*—A CAMI 150-grit ($99 \mu\text{m}$) 150 grit ($99 \mu\text{m}$) and a CAMI 240-grit ($53.5 \mu\text{m}$) 240 grit ($53.5 \mu\text{m}$) in accordance with BS 871 or its equivalent, metalworking aluminum oxide abrasive cloth coat on a jeans backing (the corresponding European grades (FEPA) are P150J and P280J, respectively), a suitable chuck (see Fig. 4) for holding the test rod, and a means of rotating the test rod at a speed of 1700 r/min to 1800 r/min .

NOTE 8—CAMI (Coated Abrasives Manufacturers Institute) is a United States organization and FEPA (Federation of European Producers of Abrasives) is a European organization.

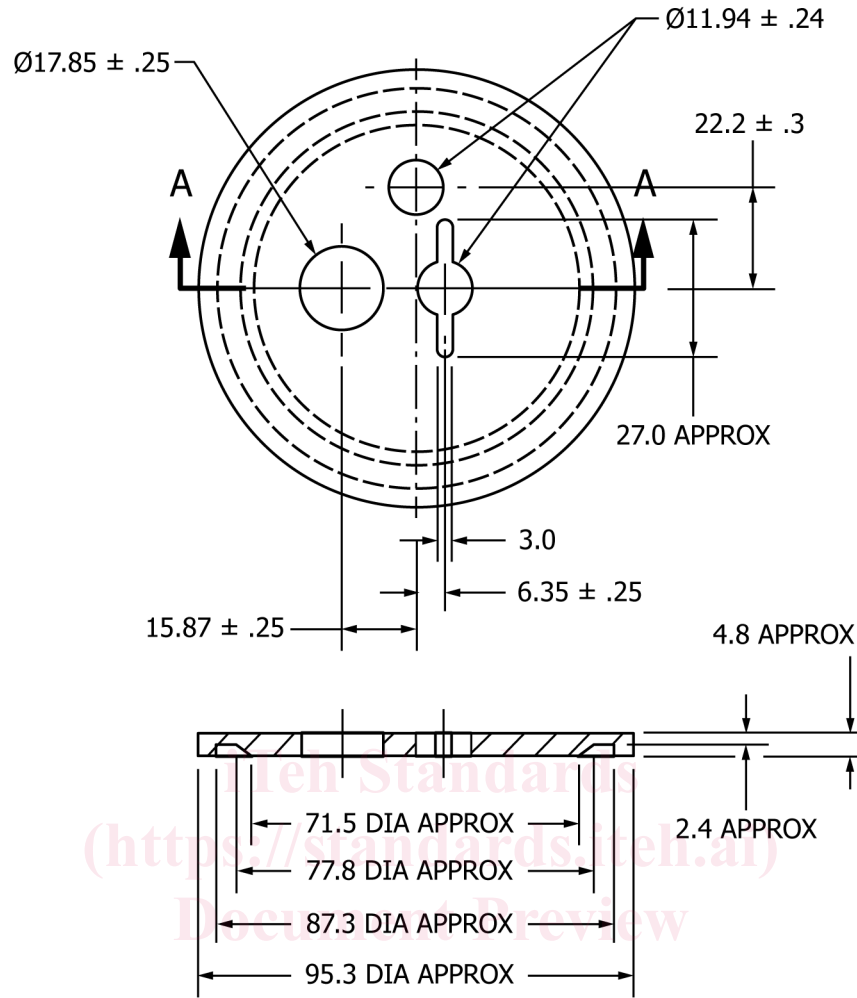

Note - All units are in millimeters, unless otherwise specified.
Tolerance for all dimensions is $\pm 10\%$ unless otherwise noted.

FIG. 2 Beaker Cover

6.8 *Oven*, capable of maintaining a temperature of 65°C . 65 °C.

7. Reagents and Materials

7.1 *Purity of Reagents*—Reagent grade chemicals shall be used in all tests. Unless otherwise indicated, it is intended that all reagents conform to the specifications of the Committee on Analytical Reagents of the American Chemical Society where such specifications are available.⁷ Other grades may be used, provided it is first ascertained that the reagent is of sufficiently high purity to permit its use without lessening the accuracy of the determination.

7.2 *Purity of Water*— Unless otherwise indicated, references to water shall be understood to mean reagent water as defined by Type II of Specification **D1193**.

⁷ *Reagent Chemicals, American Chemical Society Specifications*, American Chemical Society, Washington, DC. For suggestions on the testing of reagents not listed by the American Chemical Society, see *Analar Standards for Laboratory Chemicals*, BDH Ltd., Poole, Dorset, U.K., and the *United States Pharmacopeia and National Formulary*, U.S. Pharmacopeial Convention, Inc. (USPC), Rockville, MD.

TEST ROD HOLDERS

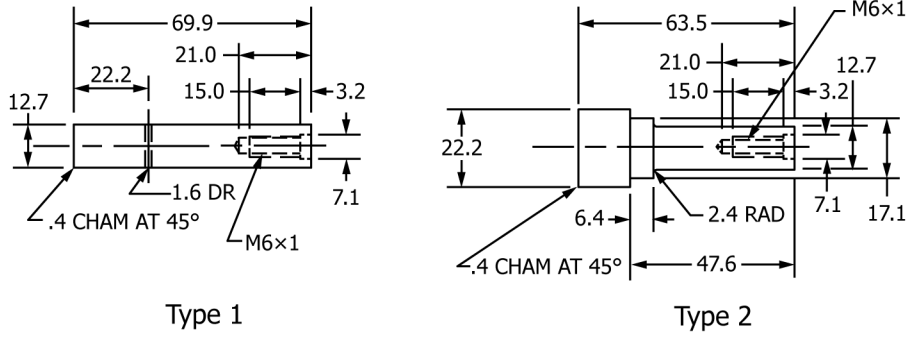

Type 1

Type 2

TEST ROD

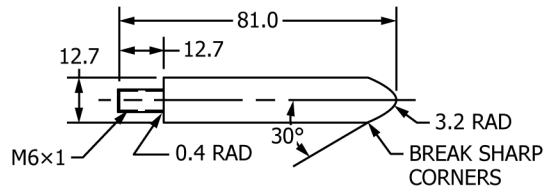

Note - All units are in millimeters, unless otherwise specified.
Tolerances for all dimensions are $\pm 10\%$ unless otherwise noted.

FIG. 3 Test Rod and Holders

iTeh Standards
(<https://standards.itih.ai>)
Document Preview

[ASTM D665-14](https://standards.itih.ai/catalog/standards/sist/77c7977e-e325-46d2-ab6f-4c5989c6be6c/astm-d665-14)

<https://standards.itih.ai/catalog/standards/sist/77c7977e-e325-46d2-ab6f-4c5989c6be6c/astm-d665-14>

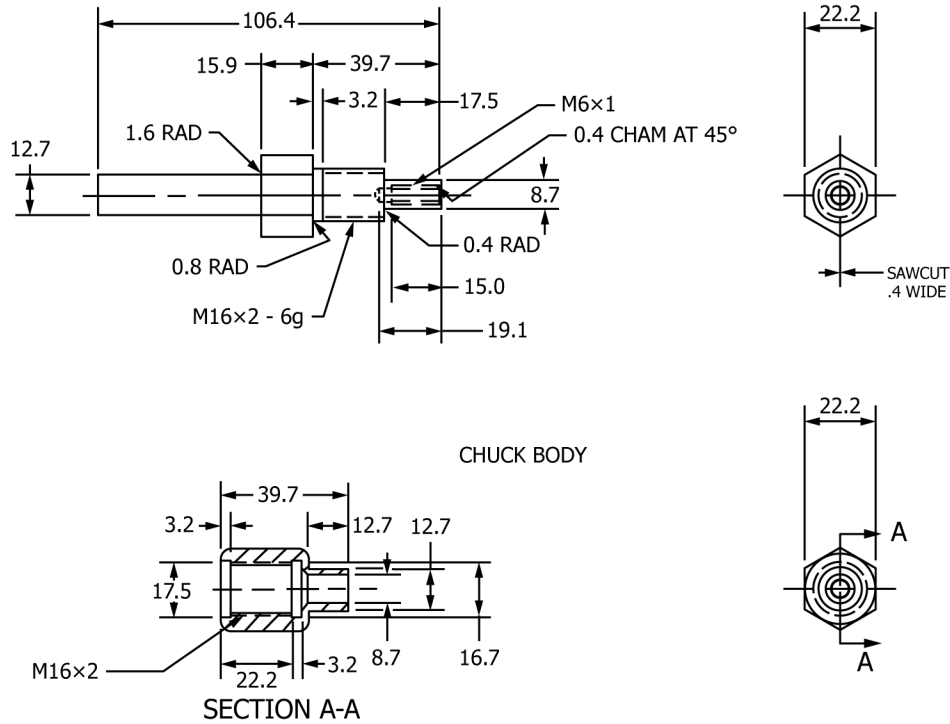

Note - All units are in millimeters, unless otherwise specified.
Tolerances for all dimensions are $\pm 10\%$ unless otherwise noted.

FIG. 4 Chuck for Polishing Test Rods

(<https://standards.iteh.ai>)
Document Preview

7.3 The synthetic sea water shall have the following composition:

Salt	g/L
NaCl	24.54 g/L
MgCl ₂ ·6H ₂ O	11.10 g/L
Na ₂ SO ₄	4.09 g/L
CaCl ₂	1.16 g/L
CaCl ₂ ·2H ₂ O	1.54 g/L
KCl	0.69 g/L
NaHCO ₃	0.20 g/L
KBr	0.10 g/L
H ₃ BO ₃	0.03 g/L
SrCl ₂ ·6H ₂ O	0.04 g/L
NaF	-0.003 g/L
NaF	0.04 g/L

7.3.1 The solution can be conveniently prepared as follows. This procedure avoids any precipitation in concentrated solutions with subsequent uncertainty of complete resolution. Using certified pure (cp) chemicals and distilled water, prepare the following stock solutions:

Stock Solution No. 1:	
MgCl ₂ ·6H ₂ O	3885 g
CaCl ₂ (anhydrous)	406 g
CaCl ₂ ·2H ₂ O	538 g
SrCl ₂ ·6H ₂ O	14 g
Dissolve and dilute to 7 L	
Stock Solution No. 2:	
KCl	483 g
NaHCO ₃	140 g
KBr	70 g
H ₃ BO ₃	21 g
NaF	2.1 g
Dissolve and dilute to 7 L	

7.3.2 To prepare the synthetic sea water, dissolve 245.4 g of NaCl and 40.94 g of Na₂SO₄ in a few litres of distilled water, add 200 mL of Stock Solution No. 1 and 100 mL of Stock Solution No. 2 and dilute to 10 L. Stir the 10-L batch, stir and add 0.1 N Na₂CO₃ solution until the pH is between 7.8 and 8.2. One or two millilitres of the carbonate solution will be required.