



**International
Standard**

ISO 22762-1

**Elastomeric seismic-protection
isolators —**

**Part 1:
Test methods**

*Appareils d'appuis structuraux en élastomère pour protection
sismique —*

Partie 1: Méthodes d'essai

**Fourth edition
2024-09**

iTeh Standards
(<https://standards.iteh.ai>)
Document Preview

[ISO 22762-1:2024](https://standards.iteh.ai/catalog/standards/iso/8d370ef4-4667-4cf2-969a-d62d95cc7a08/iso-22762-1-2024)

<https://standards.iteh.ai/catalog/standards/iso/8d370ef4-4667-4cf2-969a-d62d95cc7a08/iso-22762-1-2024>

iTeh Standards
(<https://standards.iteh.ai>)
Document Preview

[ISO 22762-1:2024](https://standards.iteh.ai/catalog/standards/iso/8d370ef4-4667-4cf2-969a-d62d95cc7a08/iso-22762-1-2024)

<https://standards.iteh.ai/catalog/standards/iso/8d370ef4-4667-4cf2-969a-d62d95cc7a08/iso-22762-1-2024>



COPYRIGHT PROTECTED DOCUMENT

© ISO 2024

All rights reserved. Unless otherwise specified, or required in the context of its implementation, no part of this publication may be reproduced or utilized otherwise in any form or by any means, electronic or mechanical, including photocopying, or posting on the internet or an intranet, without prior written permission. Permission can be requested from either ISO at the address below or ISO's member body in the country of the requester.

ISO copyright office
CP 401 • Ch. de Blandonnet 8
CH-1214 Vernier, Geneva
Phone: +41 22 749 01 11
Email: copyright@iso.org
Website: www.iso.org

Published in Switzerland

Contents

Page

Foreword	v
Introduction	vi
1 Scope	1
2 Normative references	1
3 Terms and definitions	2
4 Symbols and cross-section of elastomeric isolator	4
4.1 Symbols.....	4
4.2 Cross-section of elastomeric isolator.....	7
5 Rubber material tests	9
5.1 Test items.....	9
5.2 Test conditions and test pieces.....	9
5.3 Tensile properties.....	9
5.4 Ageing test.....	10
5.4.1 Ageing properties of inner rubber.....	10
5.4.2 Ageing properties of cover rubber.....	10
5.5 Hardness.....	10
5.6 Adhesion.....	10
5.7 Compression set.....	10
5.8 Dynamic shear properties.....	10
5.8.1 General.....	10
5.8.2 Test equipment.....	11
5.8.3 Test pieces.....	11
5.8.4 Test conditions.....	12
5.8.5 Test results.....	12
5.9 Breaking properties.....	13
5.10 Brittleness point.....	13
5.11 Ozone resistance.....	13
5.12 Low-temperature crystallization.....	13
6 Elastomeric isolator tests	14
6.1 General.....	14
6.2 Compression and shear stiffness tests.....	14
6.2.1 Compression properties.....	14
6.2.2 Compressive-shear test.....	21
6.3 Various dependence tests.....	27
6.3.1 Strain dependence of shear properties.....	27
6.3.2 Compressive force dependence of shear properties.....	28
6.3.3 Frequency dependence of shear properties.....	30
6.3.4 Repeated deformation dependence of shear properties.....	32
6.3.5 Temperature dependence of shear properties.....	34
6.3.6 Dependence of compression properties on shear strain.....	36
6.3.7 Dependence of compressive stiffness on compressive stress range.....	37
6.4 Ultimate shear properties.....	39
6.4.1 Principle.....	39
6.4.2 Test machine.....	39
6.4.3 Test piece.....	39
6.4.4 Test conditions.....	39
6.4.5 Procedure.....	39
6.4.6 Expression of results.....	40
6.4.7 Test report.....	41
6.5 Tensile testing.....	41
6.5.1 Principle.....	41
6.5.2 Test machine.....	41
6.5.3 Test piece.....	42

ISO 22762-1:2024(en)

6.5.4	Test conditions	42
6.5.5	Procedure	42
6.5.6	Expression of results	42
6.5.7	Test report	43
6.6	Durability testing	44
6.6.1	Degradation test	44
6.6.2	Creep test	45
6.6.3	Fatigue test	49
6.7	Reaction force due to low-rate deformation	51
6.7.1	Principle	51
6.7.2	Test machine	52
6.7.3	Test piece	52
6.7.4	Test conditions	52
6.7.5	Procedure	52
6.7.6	Expression of result	53
6.7.7	Test report	53
Annex A (normative) Determination of accelerated ageing conditions equivalent to expected life at standard laboratory temperature (23 °C or 27 °C)		55
Annex B (normative) Inertia force correction		58
Annex C (normative) Friction force correction		60
Annex D (normative) Determination of coefficient linear thermal expansion		63
Annex E (informative) Alternative methods of determining shear properties		65
Annex F (informative) Creep test		67
Annex G (informative) Determination of reaction force due to low-rate deformation		69
Annex H (informative) Durability investigation of elastomeric isolators used for 10 years in a bridge		71
Annex I (informative) Durability investigation of elastomeric isolators used for seven years in a building		73
Bibliography		77

<https://standards.iteh.ai/catalog/standards/iso/8d370ef4-4667-4cf2-969a-d62d95cc7a08/iso-22762-1-2024>

Foreword

ISO (the International Organization for Standardization) is a worldwide federation of national standards bodies (ISO member bodies). The work of preparing International Standards is normally carried out through ISO technical committees. Each member body interested in a subject for which a technical committee has been established has the right to be represented on that committee. International organizations, governmental and non-governmental, in liaison with ISO, also take part in the work. ISO collaborates closely with the International Electrotechnical Commission (IEC) on all matters of electrotechnical standardization.

The procedures used to develop this document and those intended for its further maintenance are described in the ISO/IEC Directives, Part 1. In particular, the different approval criteria needed for the different types of ISO document should be noted. This document was drafted in accordance with the editorial rules of the ISO/IEC Directives, Part 2 (see www.iso.org/directives).

ISO draws attention to the possibility that the implementation of this document may involve the use of (a) patent(s). ISO takes no position concerning the evidence, validity or applicability of any claimed patent rights in respect thereof. As of the date of publication of this document, ISO had not received notice of (a) patent(s) which may be required to implement this document. However, implementers are cautioned that this may not represent the latest information, which may be obtained from the patent database available at www.iso.org/patents. ISO shall not be held responsible for identifying any or all such patent rights.

Any trade name used in this document is information given for the convenience of users and does not constitute an endorsement.

For an explanation of the voluntary nature of standards, the meaning of ISO specific terms and expressions related to conformity assessment, as well as information about ISO's adherence to the World Trade Organization (WTO) principles in the Technical Barriers to Trade (TBT), see www.iso.org/iso/foreword.html.

This document was prepared by Technical Committee ISO/TC 45, *Rubber and rubber products*, Subcommittee SC 4, *Products (other than hoses)*.

This fourth edition cancels and replaces the third edition (ISO 22762-1:2018), of which it constitutes a minor revision.

The changes are as follows:

- the relation of this document to ISO 22762-5 and ISO 22762-6 have been added in Introduction;
- the normative references have been updated;
- the use of the terms "elastomeric isolators" and "seismic isolators" have been made consistent;
- the term "fracture" has been replaced by "break" throughout the document.

A list of all parts in the ISO 22762 series can be found on the ISO website.

Any feedback or questions on this document should be directed to the user's national standards body. A complete listing of these bodies can be found at www.iso.org/members.html.

Introduction

The ISO 22762 series includes two parts related to specifications for elastomeric isolators, i.e. ISO 22762-2 for bridges and ISO 22762-3 for buildings. This is because the elastomeric isolator requirements for bridges and for buildings are quite different, although the basic concept of the two products is similar. Therefore, ISO 22762-2 and the relevant clauses in this document are used when ISO 22762 (all parts) is applied to the design of bridge isolators, whereas ISO 22762-3 and the relevant clauses of this document are used when it is applied to building isolators.

The main differences to be noted between elastomeric isolators for bridges and elastomeric isolators for buildings are the following.

- a) Elastomeric isolators for bridges are mainly rectangular in shape and those for buildings are circular in shape.
- b) Elastomeric isolators for bridges are designed to be used for both rotation and horizontal displacement, while elastomeric isolators for buildings are designed for horizontal displacement only.
- c) Elastomeric isolators for bridges are designed to perform on a daily basis to accommodate length changes of bridges caused by temperature changes as well as during earthquakes, while elastomeric isolators for buildings are designed to perform only during earthquakes.
- d) Elastomeric isolators for bridges are designed to withstand dynamic loads caused by vehicles on a daily basis as well as earthquakes, while elastomeric isolators for buildings are mainly designed to withstand dynamic loads caused by earthquakes only.

For structures other than buildings and bridges (e.g. tanks), the structural engineer uses either ISO 22762-2 or ISO 22762-3, depending on the requirements of the structure.

ISO/TS 22762-4 is a guidance for the use of ISO 22762-3. ISO 22762-5 gives specifications and test methods for sliding seismic-protection isolators which are not specified as elastomeric isolators. ISO 22762-6 gives specifications and test methods for high-durability and high-performance elastomeric isolators. Three grades of requirements for each test item are introduced in ISO 22762-6.

[ISO 22762-1:2024](https://standards.iteh.ai/catalog/standards/iso/8d370ef4-4667-4cf2-969a-d62d95cc7a08/iso-22762-1-2024)

<https://standards.iteh.ai/catalog/standards/iso/8d370ef4-4667-4cf2-969a-d62d95cc7a08/iso-22762-1-2024>

Elastomeric seismic-protection isolators —

Part 1: Test methods

1 Scope

This document specifies the test methods for determination of

- a) the properties of the rubber material used to manufacture the elastomeric isolators, and
- b) the characteristics of elastomeric isolators.

It is applicable to elastomeric isolators used to provide buildings or bridges with protection from earthquake damage. The elastomeric isolators covered consist of alternate elastomeric layers and reinforcing steel plates which are placed between a superstructure and its substructure to provide both flexibility for decoupling structural systems from ground motion, and damping capability to reduce displacement at the isolation interface and the transmission of energy from the ground into the structure at the isolation frequency.

2 Normative references

The following documents are referred to in the text in such a way that some or all of their content constitutes requirements of this document. For dated references, only the edition cited applies. For undated references, the latest edition of the referenced document (including any amendments) applies.

ISO 48-2, *Rubber, vulcanized or thermoplastic — Determination of hardness — Part 2: Hardness between 10 IRHD and 100 IRHD*

ISO 48-5, *Rubber, vulcanized or thermoplastic — Determination of hardness — Part 2: Indentation hardness by IRHD pocket meter method*

ISO 188, *Rubber, vulcanized or thermoplastic — Accelerated ageing and heat resistance tests*

ISO 812, *Rubber, vulcanized or thermoplastic — Determination of low-temperature brittleness*

ISO 813, *Rubber, vulcanized or thermoplastic — Determination of adhesion to a rigid substrate — 90 degree peel method*

ISO 815-1, *Rubber, vulcanized or thermoplastic — Determination of compression set — Part 1: At ambient or elevated temperatures*

ISO 815-2, *Rubber, vulcanized or thermoplastic — Determination of compression set — Part 2: At low temperatures*

ISO 1431-1, *Rubber, vulcanized or thermoplastic — Resistance to ozone cracking — Part 1: Static and dynamic strain testing*

ISO 1827, *Rubber, vulcanized or thermoplastic — Determination of shear modulus and adhesion to rigid plates — Quadruple-shear methods*

ISO 3387, *Rubber — Determination of crystallization effects by hardness measurements*

ISO 4664-1, *Rubber, vulcanized or thermoplastic — Determination of dynamic properties — Part 1: General guidance*

ISO 7500-1:2018, *Metallic materials — Calibration and verification of static uniaxial testing machines — Part 1: Tension/compression testing machines — Calibration and verification of the force-measuring system*

ISO 22762-2, *Elastomeric seismic-protection isolators — Part 2: Applications for bridges — Specifications*

ISO 22762-3, *Elastomeric seismic-protection isolators — Part 3: Applications for buildings — Specifications*

ISO 23529, *Rubber — General procedures for preparing and conditioning test pieces for physical test methods*

3 Terms and definitions

For the purposes of this document, the following terms and definitions apply.

ISO and IEC maintain terminological databases for use in standardization at the following addresses:

- ISO Online browsing platform: available at <https://www.iso.org/obp/>
- IEC Electropedia: available at <https://www.electropedia.org/>

3.1

breaking

rupture of *elastomeric isolator* (3.9) due to compression- (or tension-) shear loading

3.2

buckling

state when *elastomeric isolator* (3.9) lose their stability under compression-shear loading

3.3

compressive properties

K_v
compressive stiffness for all types of *elastomeric isolator* (3.9)

3.4

compression-shear testing machine

machine used to test *elastomeric isolator* (3.9), which has the capability of shear loading under constant compressive load

<https://standards.iteh.ai/catalog/standards/iso/8d370ef4-4667-4cf2-969a-d62d95cc7a08/iso-22762-1-2024>

3.5

cover rubber

rubber wrapped around the outside of inner rubber and reinforcing steel plates before or after curing of *elastomeric isolator* (3.9) for the purposes of protecting the inner rubber from deterioration due to oxygen, ozone and other natural elements and protecting the reinforcing plates from corrosion

3.6

design compressive stress

long-term compressive force on the *elastomeric isolator* (3.9) imposed by the structure

3.7

effective loaded area

area sustaining vertical load in *elastomeric isolator* (3.9), which corresponds to the area of reinforcing steel plates

3.8

effective width

<rectangular elastomeric isolator> the smaller of the two side lengths of inner rubber to which direction shear displacement is not restricted

3.9

elastomeric isolator

rubber bearing, for seismic isolation of buildings, bridges and other structures, which consists of multi-layered vulcanized rubber sheets and reinforcing steel plates

EXAMPLE High-damping rubber bearings, linear natural rubber bearings and lead rubber bearings.

3.10

first shape factor

ratio of effective loaded area to free deformation area of one inner rubber layer between steel plates

3.11

high-damping rubber bearing

HDR

elastomeric isolator (3.9) with relatively high damping properties obtained by special compounding of the rubber and the use of additives

3.12

inner rubber

rubber between multi-layered steel plates inside an *elastomeric isolator* (3.9)

3.13

lead rubber bearing

LRB

elastomeric isolator (3.9) whose *inner rubber* (3.12) with a lead plug or lead plugs press fitted into a hole or holes of the elastomeric isolator body to achieve damping properties

3.14

linear natural rubber bearing

LNR

elastomeric isolator (3.9) with linear shear force-deflection characteristics and relatively low damping properties, fabricated using natural rubber

Note 1 to entry: Any bearing with relatively low damping can be treated as an LNR bearing for the purposes of elastomeric isolator testing.

3.15

maximum compressive stress

peak stress acting briefly on *elastomeric isolator* (3.9) in compressive direction during an earthquake

3.16

nominal compressive stress

long-term stress acting on *elastomeric isolator* (3.9) in compressive direction as recommended by the manufacturer for the elastomeric isolator, including the safety margin

3.17

post-yield stiffness

shear stiffness of LRB after yielding of lead plug

3.18

roll-out

instability of an *elastomeric isolator* (3.9) with either dowelled or recessed connection under shear displacement

3.19

routine test

test for quality control of the production *elastomeric isolator* (3.9) during and after manufacturing

3.20

second shape factor

<circular elastomeric isolator> ratio of the diameter of the inner rubber to the total thickness of the inner rubber

3.21

second shape factor

<rectangular or square elastomeric isolator> ratio of the effective width of the inner rubber to the total thickness of the inner rubber

3.22

shear properties

comprehensive term that covers characteristics determined from *elastomeric isolator* (3.9) tests:

- shear stiffness, K_h , for LNR;
- shear stiffness, K_h , and equivalent damping ratio, h_{eq} , for HDR and LRB;
- post-yield stiffness, K_d , and characteristic strength, Q_d , for LRB

3.23

structural engineer

engineer who is in charge of designing the structure for seismically isolated bridges or buildings and is responsible for specifying the requirements for *elastomeric isolator* (3.9)

3.24

ultimate properties

property at either buckling, breaking, or roll-out of an *elastomeric isolator* (3.9) under compression-shear loading

4 Symbols and cross-section of elastomeric isolator

4.1 Symbols

For the purposes of this document, the symbols given in [Table 1](#) apply.

Table 1 — Symbols and descriptions

Symbol	Description
A	effective plan area; plan area of elastomeric isolator, excluding cover rubber portion
A_b	effective area of bolt
A_e	overlap area between the top and bottom elastomer area of elastomeric isolator
A_{free}	load-free area of elastomeric isolator
A_{load}	loaded area of elastomeric isolator
A_p	area of the lead plug for a lead rubber bearing
a	side length of square elastomeric isolator, excluding cover rubber thickness, or length in longitudinal direction of rectangular elastomeric isolator, excluding cover rubber thickness
a_e	length of the shorter side of the rectangular elastomeric isolator, including cover rubber thickness
a'	length in longitudinal direction of the rectangular elastomeric isolator, including cover rubber thickness
B	effective width for bending of flange
b	length in transverse direction of the rectangular elastomeric isolator, excluding cover rubber thickness
b'	length in transverse direction of the rectangular elastomeric isolator, including cover rubber thickness
c	distance from centre of bolt hole to effective flange section
D'	outer diameter of circular elastomeric isolator, including cover rubber
D_f	diameter of flange
d_i	inner diameter of reinforcing steel plate
d_k	diameter of bolt hole
d_o	outer diameter of reinforcing steel plate
E_{ap}	apparent Young's modulus of bonded rubber layer
E_c	apparent Young's modulus corrected, if necessary, by allowing for compressibility
E_c^s	apparent Young's modulus corrected for bulk compressibility depending on its shape factor (S_1)
E_∞	bulk modulus of rubber
E_0	Young's modulus of rubber

Table 1 (continued)

Symbol	Description
F_u	tensile force on elastomeric isolator by uplift
G	shear modulus
$G_{eq}(\gamma)$	equivalent linear shear modulus as a function of shear strain
H	height of elastomeric isolator, including mounting flange
H_n	height of elastomeric isolator, excluding mounting flange
h_{eq}	equivalent damping ratio
$h_{eq}(\gamma)$	equivalent damping ratio as a function of shear strain
K_d	post-yield stiffness (tangential stiffness after yielding of lead plug) of lead rubber bearing
K_h	shear stiffness
K_i	initial shear stiffness
K_p	shear stiffness of lead plug inserted in lead rubber bearing
K_r	shear stiffness of lead rubber bearing before inserting lead plug
K_t	tangential shear stiffness
K_v	compressive stiffness
L_f	length of one side of a rectangular flange
M	resistance to rotation
M_f	moment acting on bolt
M_r	moment acting on elastomeric isolator
n	number of rubber layers
n_b	number of fixing bolts
P	compressive force
P_0	design compressive force in absence of seismic action effects
P_{max}	maximum compressive force including seismic action effects
P_{min}	minimum compressive force including seismic actions effects
Q	shear force
Q_b	shear force at breaking
Q_{buk}	shear force at buckling
Q_d	characteristic strength
S_1	first shape factor
S_2	second shape factor
T	Temperature
T_L	minimum temperature
T_0	standard temperature, 23 °C or 27 °C where specified tolerance is ± 2 °C, it is standard laboratory temperature
T_r	total rubber thickness, given by $T_r = n \times t_r$
t_r	thickness of one rubber layer
t_{r1}, t_{r2}	thickness of rubber layer laminated on each side of plate
t_s	thickness of one reinforcing steel plate
t_0	thickness of outside cover rubber
$U(\gamma)$	function giving ratio of characteristic strength to maximum shear force of a loop
v	loading velocity
W_d	energy dissipated per cycle
X	shear displacement
X_0	design shear displacement

Table 1 (continued)

Symbol	Description
X_b	shear displacement at break
X_{buk}	shear displacement at buckling
X_s	shear displacement due to quasi-static shear movement
X_{max}	maximum shear displacement
X_d	shear displacement due to dynamic shear movement
Y	compressive displacement
Z	section modulus of flange
α	coefficient of linear thermal expansion
γ	shear strain
γ_0	design shear strain
γ_a	upper limit of the total of design strains on elastomeric isolators
γ_b	shear strain at breaking
γ_c	local shear strain due to compressive force
γ_d	shear strain due to dynamic shear movement
γ_{max}	maximum design shear strain during earthquake
γ_r	local shear strain due to rotation
γ_s	shear strain due to quasi-static shear movement
γ_u	ultimate shear strain
δ_H	horizontal offset of elastomeric isolator
δ_v	difference in isolator height measured between two points at opposite extremes of the elastomeric isolator
ε	compressive strain of rubber
ε_{cr}	creep strain
ε_T	tensile strain of elastomeric isolator
ε_{Tb}	tensile-breaking strain of elastomeric isolator
ε_{Ty}	tensile-yield strain of elastomeric isolator
ζ	ratio of total height of rubber and steel layers to total rubber height
θ	rotation angle of elastomeric isolator about the diameter of a circular bearing or about an axis through a rectangular bearing
θ_a	rotation angle of elastomeric isolator in the longitudinal direction (a)
θ_b	rotation angle of elastomeric isolator in the transverse direction (b)
λ	correction factor for calculation of stress in reinforcing steel plates
η	correction factor for calculation of critical stress
κ	correction factor for apparent Young's modulus according to hardness
$\Sigma\gamma$	total local shear strain
σ	compressive stress in elastomeric isolator
σ_0	design compressive stress
σ_B	tensile stress in bolt
σ_b	bending stress in flange
σ_{bf}	allowable bending stress in steel
σ_{cr}	critical stress in elastomeric isolator
σ_f	allowable tensile stress in steel
σ_{max}	maximum design compressive stress
σ_{min}	minimum design compressive stress
σ_{nom}	for building: nominal compressive stress recommended by manufacturer

Table 1 (continued)

Symbol	Description
σ_s	tensile stress in reinforcing steel plate
σ_{sa}	allowable tensile stress in steel plate
σ_{sy}	yield stress of steel for flanges and reinforcing steel plates
σ_{su}	tensile strength of steel for flanges and reinforcing steel plates
σ_t	tensile stress
σ_{te}	allowable tensile stress in elastomeric isolator
τ_B	shear stress in bolt
τ_f	allowable shear stress in steel
ϕ	factor for computation of buckling stability
ξ	factor for computation of critical stress

4.2 Cross-section of elastomeric isolator

A typical cross-section of the elastomeric isolator is given in [Figure 1](#).

iTeh Standards
(<https://standards.itih.ai>)
Document Preview

[ISO 22762-1:2024](#)

<https://standards.itih.ai/catalog/standards/iso/8d370ef4-4667-4cf2-969a-d62d95cc7a08/iso-22762-1-2024>

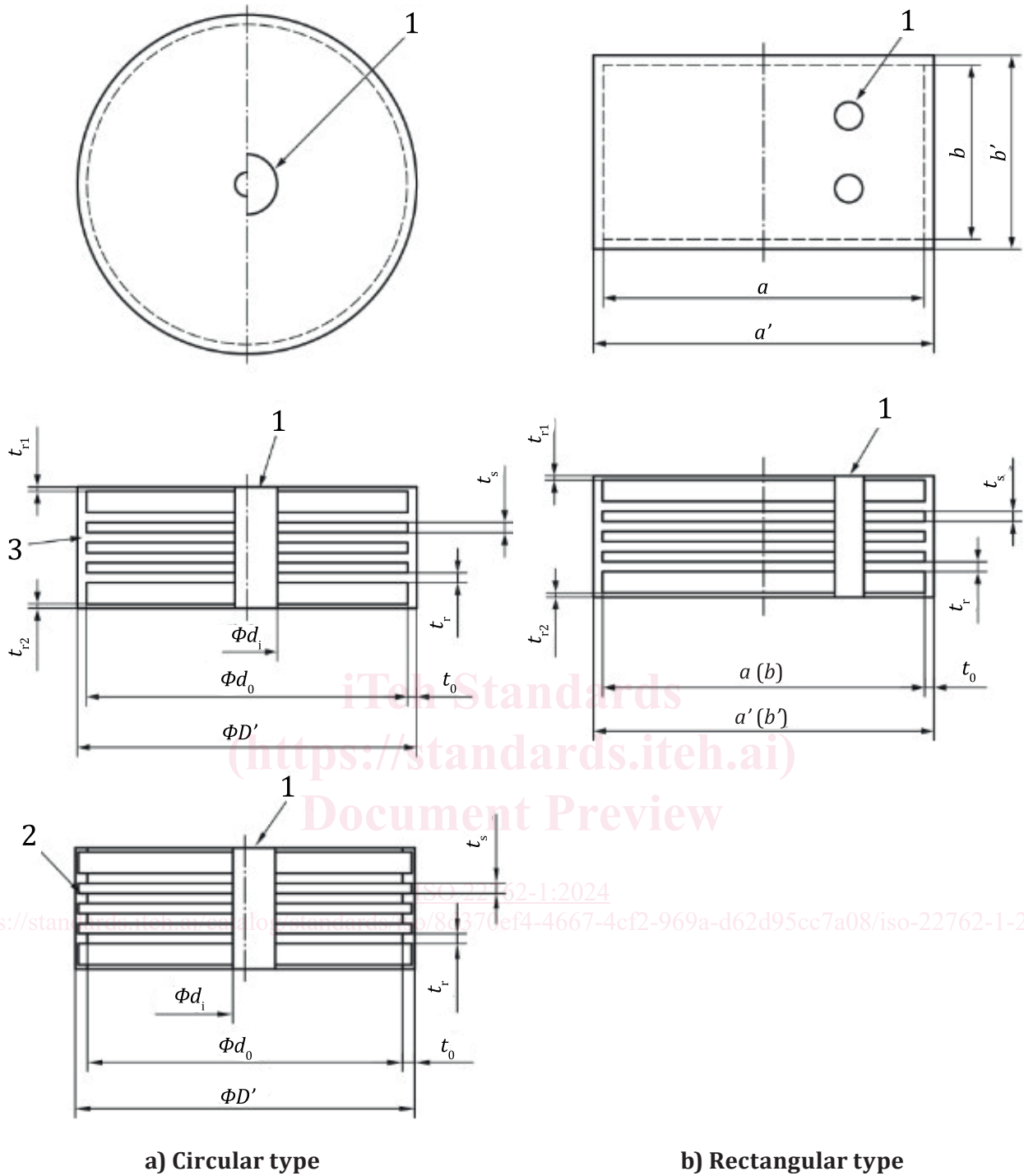

Key

- 1 lead plug
- 2 cover rubber added after elastomeric isolator cured
- 3 cover rubber cured with isolator

NOTE The left-hand side of the figure shows LNR and HDR, the right-hand side shows LRB.

Figure 1 — Cross-section of isolator