



Designation: ~~D2265~~—~~06~~ D2265 – 06 (Reapproved 2014)

Standard Test Method for Dropping Point of Lubricating Grease Over Wide Temperature Range¹

This standard is issued under the fixed designation D2265; the number immediately following the designation indicates the year of original adoption or, in the case of revision, the year of last revision. A number in parentheses indicates the year of last reapproval. A superscript epsilon (ϵ) indicates an editorial change since the last revision or reapproval.

This standard has been approved for use by agencies of the U.S. Department of Defense.

1. Scope

1.1 This test method covers the determination of the dropping point of lubricating grease.

1.2 *This standard does not purport to address all of the safety concerns, if any, associated with its use. It is the responsibility of the user of this standard to establish appropriate safety and health practices and determine the applicability of regulatory limitations prior to use.*

2. Referenced Documents

2.1 *ASTM Standards:*²

[D217 Test Methods for Cone Penetration of Lubricating Grease](#)

[D566 Test Method for Dropping Point of Lubricating Grease](#)

[D3244 Practice for Utilization of Test Data to Determine Conformance with Specifications](#)

[E1 Specification for ASTM Liquid-in-Glass Thermometers](#)

3. Terminology

3.1 *Definitions:*

3.1.1 *dropping point, n*—a numerical value assigned to a grease composition representing the corrected temperature at which the first drop of material falls from the test cup and reaches the bottom of the test tube.

¹ This test method is under the jurisdiction of ASTM Committee D02 on Petroleum Products—Products, Liquid Fuels, and Lubricants and is the direct responsibility of Subcommittee D02.G0.03 on Physical Tests.

Current edition approved May 1, 2006 Nov. 1, 2014. Published May 2006 November 2014. Originally approved in 1964. Last previous edition approved in 2000 2006 as D2265 D2265 – 06. DOI: 10.1520/D2265-06-10.1520/D2265-06R14.

² For referenced ASTM standards, visit the ASTM website, www.astm.org, or contact ASTM Customer Service at service@astm.org. For *Annual Book of ASTM Standards* volume information, refer to the standard's Document Summary page on the ASTM website.

3.1.1.1 Discussion—

In the normal and proper operation of this test method, the observed dropping point is corrected by adding to it a value representing one third of the difference between the oven block temperature and the observed dropping point temperature. This corrected value is recorded as the dropping point of the grease.

3.1.2 *lubricating grease, n*—a semi-fluid to solid product of a thickener in a liquid lubricant.

3.1.2.1 Discussion—

The dispersion of the thickener forms a two-phase system and immobilizes the liquid lubricant by surface tension and other physical forces. Other ingredients are commonly included to impart special properties. **D217**

3.1.3 *observed dropping point, n*—the value noted on the thermometer monitoring the internal temperature of the grease test cup when the first drop of material falls from the test cup and reaches the bottom of the test tube.

3.1.4 *thickener, n—in lubricating grease*, a substance composed of finely-divided particles dispersed in a liquid to form the product's structure.

3.1.4.1 Discussion—

Thickeners can be fibers (such as various metallic soaps) or plates or spheres (such as certain non-soap thickeners), which are insoluble or, at most, only very slightly soluble in the liquid lubricant. The general requirements are that the solid particles be extremely small, uniformly dispersed, and capable of forming a relatively stable, gel-like structure with the liquid lubricant. **D217**

4. Summary of Test Method

4.1 A grease sample in a grease test cup is supported in a test tube placed in an aluminum block oven at a preset constant temperature. A sample thermometer is placed in the tube and so positioned that it measures the temperature in the sample cup without coming in contact with the grease.

4.2 As the temperature increases, at some point a drop of material will fall from the cup to the bottom of the test tube. The reading on the sample thermometer is recorded to the nearest degree as the observed dropping point. At the same time, the temperature of the aluminum block oven is also recorded to the nearest degree.

4.3 One third the difference between the two values is the correction factor which is added to the observed value and recorded as the dropping point of the grease.

5. Significance and Use

5.1 The dropping point is useful to assist in identifying the grease as to type and for establishing and maintaining bench marks for quality control. The results are to be considered to have only limited significance with respect to service performance because dropping point is a static test.

5.2 Cooperative testing³ indicates that, in general, dropping points by Test Method D2265 and Test Method **D566** are in agreement up to 260°C. In cases where results differ, there is no known significance. However, agreement between the manufacturer and purchaser as to test method used is advisable.

6. Apparatus

6.1 *Dropping Point Assembly* (**Fig. 1**) consisting of the following:

6.1.1 *Grease Cup*, chromium-plated brass cup conforming to the dimensions shown in **A, Fig. 1**.

6.1.2 *Test Tube*, thin walled, soft glass test tube with rim, having dimensions shown in **B, Fig. 1**.

6.1.3 *Cup Support*, glass tubing as shown in **C, Fig. 1**.

6.1.4 *Thermometer*, thermometer 3C as prescribed in Specification **E1** and shown in **D, Fig. 1**.

6.1.5 *Accessories*, thermometer clamp as shown in **E-1**, bushings as shown in **E-2** and **E-3**, bushing support ring as shown in **E-4**, thermometer depth gage as shown in **E-5**, a metal rod as shown in **E-6**, and cup gage as shown in **E-7**, all of **Fig. 1**.

6.2 *Aluminum Block Oven*, aluminum block oven of the design and dimensions shown in **Fig. 2**. The block shall be equipped with an integral cartridge-type heater. Control of the current to the heater shall be used to obtain and maintain the desired oven temperature.

6.2.1 *Aluminum Block Oven Thermometer*, conforming to thermometer 11C in accordance with Specification **E1**.

7. Sampling

7.1 The sample presented for analysis should be large enough to make possible the selection of a representative portion for testing. Examine for any indication of non-homogeneity such as oil separation, phase changes, or gross contamination. If any abnormal conditions are found, obtain a new sample.

8. Preparation of Apparatus

8.1 Thoroughly clean the cup, cup support, and test tube with mineral spirits. (**Warning**—Flammable. Vapor harmful.)

8.2 Use only cups that are clean and free of any residue. When the interior plating of the cup shows indications of wear, discard.

8.3 When new cups are to be used, check their dimensions by using the cup plug gage (**E-7** of **Fig. 1**). To check the bottom opening of the cup a 2.78 mm rod should fit easily while a 2.82 mm rod should not.⁴ If the hole is undersize, ream to the correct size. If too large, discard. Cups of the proper dimensions need not be rechecked before each test run.

8.4 Test tubes shall be clean and free of residues and conform to the dimensions shown in **B, Fig. 1**. Inspect for chips or cracks and replace when necessary.

8.5 Sample thermometer bulb shall be clean and free of residues. Inspect bushings for cleanliness and be certain the thermometer clamp, **E-1, Fig. 1**, is sufficiently tight to hold the thermometer in position.

³ Supporting data have been filed at ASTM International Headquarters and may be obtained by requesting Research Report RR:D02-1164.

⁴ These are commonly available as a 7/64-in. drill and a No. 34 drill, respectively.

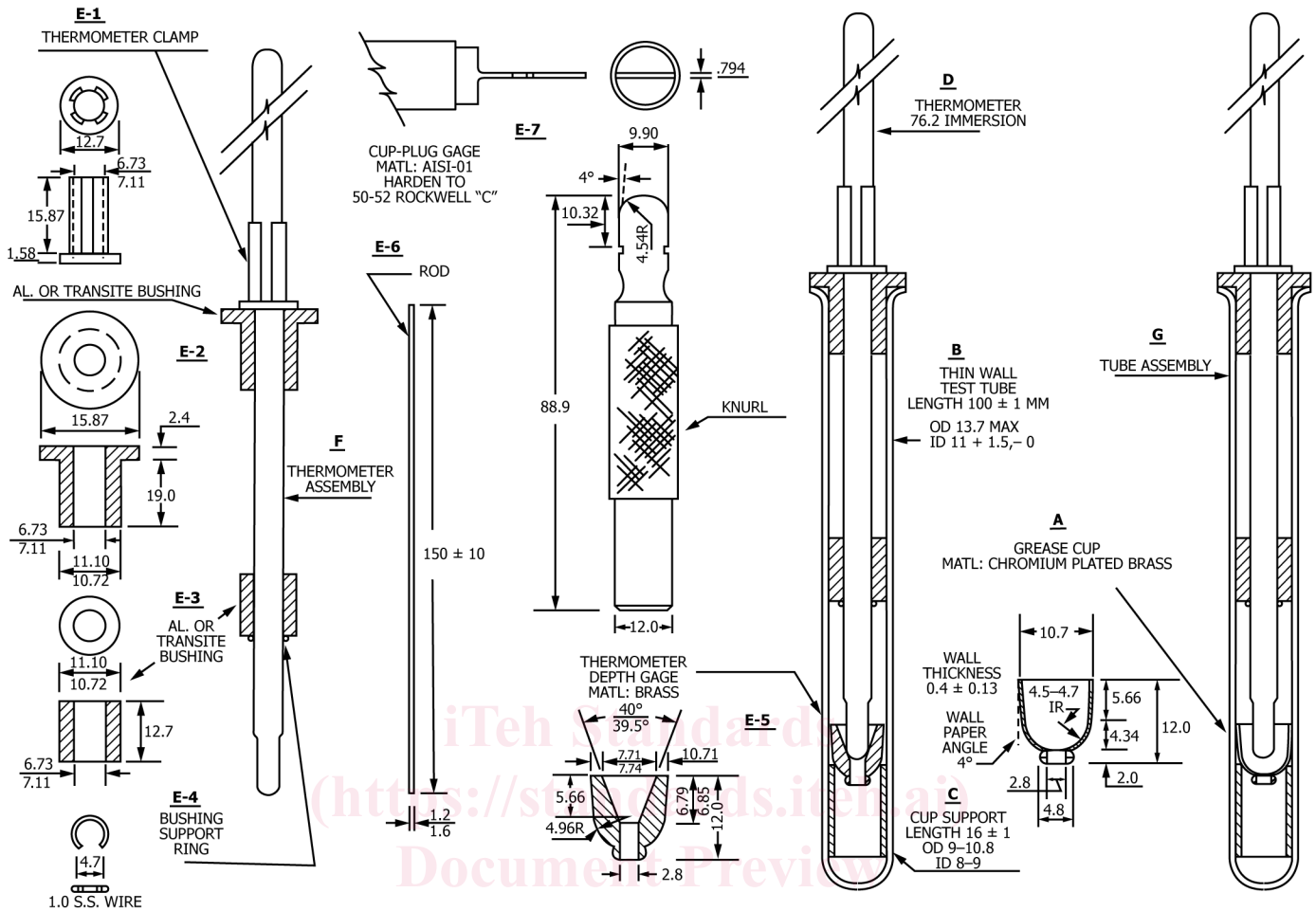

(a) Dimensions in millimetres.

FIG. 1 Apparatus for Dropping Point Test of Lubricating Grease

8.6 The glass sleeve used to support the cup shall be free of any cracks or chips, residue or stain, and conform to the dimensions shown in C, Fig. 1. Replace when necessary.

9. Procedure

9.1 Insert empty test tubes in every test tube well and a thermometer having a range from -5 to 400°C in the thermometer well of the oven.

9.2 Turn on the oven and select the lowest aluminum block oven temperature setting from the four listed below that will result in an observed dropping point at or below the corresponding maximum observed dropping point shown for that oven temperature setting.

Oven Temperature, $^\circ\text{C}$	Maximum Observed Dropping Point, $^\circ\text{C}$
121 ± 3	116
232 ± 3	221
288 ± 3	277
316 ± 3	304

9.3 Select and use test tubes and accessories E-1, E-2, and E-3 to minimize wobble of the thermometer. All components must be at room temperature prior to the test. Place the components E-1 through E-4 on the thermometer in the order shown by the thermometer assembly (F) Fig. 1. Adjust the bushing E-3 and the bushing support ring E-4 so that E-4 is about 25 mm from the tip of the thermometer. Place the cup support C in tube B. Insert the thermometer depth gage E-5 and the thermometer assembly in the tube. Position the thermometer so that the tip bottoms in the gage. Adjust the bushing E-2 and the thermometer clamp E-1 so that the bushing shoulders on the top edge of the tube.