



Designation: D3380 – 14

Standard Test Method for Relative Permittivity (Dielectric Constant) and Dissipation Factor of Polymer-Based Microwave Circuit Substrates¹

This standard is issued under the fixed designation D3380; the number immediately following the designation indicates the year of original adoption or, in the case of revision, the year of last revision. A number in parentheses indicates the year of last reapproval. A superscript epsilon (ϵ) indicates an editorial change since the last revision or reapproval.

1. Scope*

1.1 This test method permits the rapid measurement of apparent relative permittivity and loss tangent (dissipation factor) of metal-clad polymer-based circuit substrates in the X-band (8 to 12.4 GHz).

1.2 This test method is suitable for testing PTFE (polytetrafluorethylene) impregnated glass cloth or random-oriented fiber mats, glass fiber-reinforced polystyrene, polyphenyleneoxide, irradiated polyethylene, and similar materials having a nominal specimen thickness of $\frac{1}{16}$ in. (1.6 mm). The materials listed in the preceding sentence have been used in commercial applications at nominal frequency of 9.6 GHz.

NOTE 1—See Appendix X1 for additional information about range of permittivity, thickness other than 1.6 mm, and tests at frequencies other than 9.6 GHz.

1.3 The values stated in inch-pound units are to be regarded as standard. The values given in parentheses are mathematical conversions to SI units that are provided for information only and are not considered standard.

1.4 *This standard does not purport to address all of the safety concerns, if any, associated with its use. It is the responsibility of the user of this standard to establish appropriate safety and health practices and determine the applicability of regulatory limitations prior to use.*

2. Referenced Documents

2.1 ASTM Standards:²

- D150 Test Methods for AC Loss Characteristics and Permittivity (Dielectric Constant) of Solid Electrical Insulation
- D1711 Terminology Relating to Electrical Insulation

¹ This test method is under the jurisdiction of ASTM Committee D09 on Electrical and Electronic Insulating Materials and is the direct responsibility of Subcommittee D09.12 on Electrical Tests.

Current edition approved Nov. 1, 2014. Published November 2014. Originally approved in 1975. Last previous edition approved in 2010 as D3380 – 10. DOI: 10.1520/D3380-14.

² For referenced ASTM standards, visit the ASTM website, www.astm.org, or contact ASTM Customer Service at service@astm.org. For *Annual Book of ASTM Standards* volume information, refer to the standard's Document Summary page on the ASTM website.

D2520 Test Methods for Complex Permittivity (Dielectric Constant) of Solid Electrical Insulating Materials at Microwave Frequencies and Temperatures to 1650°C

D6054 Practice for Conditioning Electrical Insulating Materials for Testing (Withdrawn 2012)³

2.2 IPC Standards:⁴

IPC-TM-650 Test Methods Manual Method 2.5.5.5.

IPC-MF-4562 Metal Foil for Printed Wiring Applications.

2.3 IEEE Standards:⁵

Standard No. 488.1 Standard Digital Interface for Programmable Instrumentation.

Standard No. 488.2 Standards, Codes, Formats, Protocols and Common Commands for Use with ANSI and IEEE Standard 488.1.

3. Terminology

3.1 *Definitions*—See Terminology D1711 for the definitions of terms used in this test method. See also Test Methods D2520, D150, and IPC TM-650 for additional information regarding the terminology.

3.2 Definitions of Terms Specific to This Standard:

3.2.1 *D*—a symbol used in this test method for the dissipation factor.

3.2.2 ΔL —a correction factor associated with length which corrects for the fringing capacitance at the ends of the resonator element.

3.2.3 κ' —symbol used in this test method to denote relative permittivity.

3.2.3.1 *Discussion*—The preferred symbol for permittivity is Greek kappa prime, but some persons use other symbols to denote this property such as *DK*, *SIC*, or ϵ'_R .

3.2.4 *microstrip line, n*—a microwave transmission line employing a flat strip conductor bonded to one surface of a dielectric board or sheet, the other surface of which is clad with, or bonded to, a continuous conductive foil or plate which is substantially wider than the strip.

³ The last approved version of this historical standard is referenced on www.astm.org.

⁴ Available from IPC, 3000 Lakeside Drive, Suite 309S, Bannockburn, IL 60015.

⁵ Available from Institute of Electrical and Electronics Engineers, Inc. (IEEE), 445 Hoes Ln., P.O. Box 1331, Piscataway, NJ 08854-1331, http://www.ieee.org.

*A Summary of Changes section appears at the end of this standard

3.2.4.1 *Discussion*—Microstrip provides easier accessibility than stripline for attaching components and devices to the strip circuitry.

3.2.5 *microwave substrate, n*—a board or sheet of low-loss dielectric material that is clad with metal foil either on one or both surfaces, from which all metal is removed by etching prior to testing.

3.2.6 *stripline, n*—microwave transmission line using a flat strip conductor clamped, or bonded, between two substantially wider dielectric boards.

3.2.6.1 *Discussion*—The outer surfaces of both boards are bonded to, or in intimate contact with, conducting foils or plates (ground planes). Picture a stripline as a flattened version of cylindrical coaxial cable.

3.2.7 *stripline resonator, n*—a disconnected section of strip-line loosely coupled at each end by capacitive gaps to feed or probe lines.

3.2.7.1 *Discussion*—The strip becomes resonant at those frequencies at which the strip length, increased by an increment due to the fringing fields at the ends, is equal to an integral multiple of half-wavelengths in the dielectric. As frequency varies gradually, the power transmitted from the input to the output feed lines becomes maximum at resonance, and falls off sharply to essentially zero at frequencies which are a few parts per thousand above and below resonance.

4. Summary of Test Method

4.1 Substrate specimens, with metal cladding removed, become the supporting dielectric spacers of a microwave stripline resonator when properly positioned and clamped in the test fixture. The measured values of resonant frequency of the stripline resonator and the half-power frequencies are used to compute the relative permittivity (dielectric constant or κ') and the dissipation factor (D) of the test specimen. The test specimen consists of one or more pairs of test cards.

5. Significance and Use

5.1 Permittivity and dissipation factor are fundamental design parameters for design of microwave circuitry. Permittivity plays a principal role in determining the wavelength and the impedance of transmission lines. Dissipation factor (along with copper losses) influence attenuation and power losses.

5.2 This test method is suitable for polymeric materials having permittivity in the order of two to eleven. Such materials are popular in applications of stripline and microstrip configurations used in the 1 to 18 GHz range.

5.3 This test method is suitable for design, development, acceptance specifications, and manufacturing quality control.

NOTE 2—See Appendix X1 for additional information regarding significance of this test method and the application of the results.

6. Apparatus

6.1 The preferred assembly fixture shown in Figs. 1-3 is hereby designated Fixture A. This design of test specimen fixture provides advantages over the design of Fixture B, shown in Figs. 4-7.

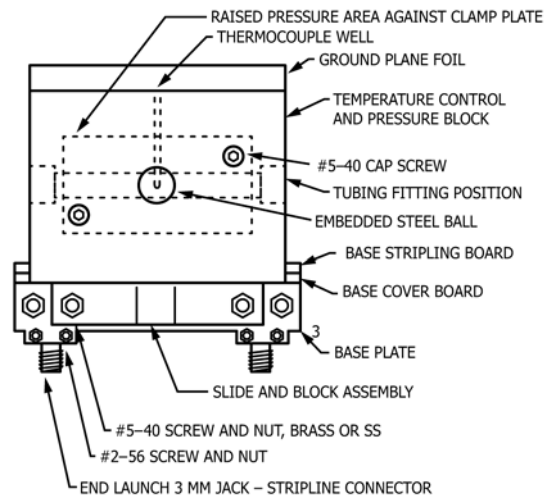

FIG. 1 Face View of Fixture Assembly

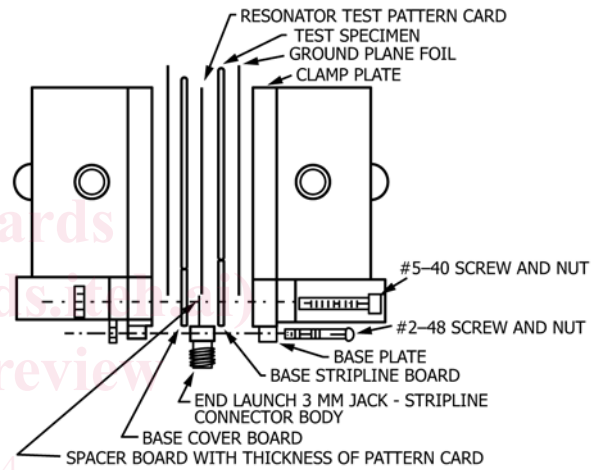

FIG. 2 Exploded Side View of Assembly

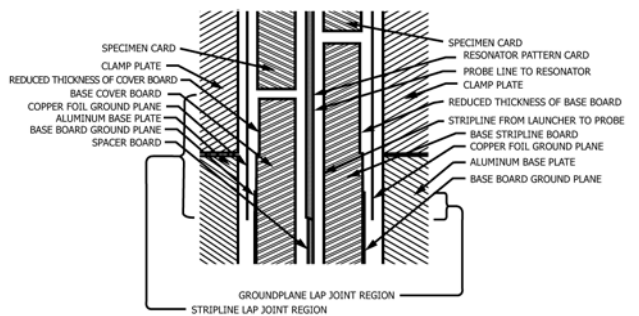
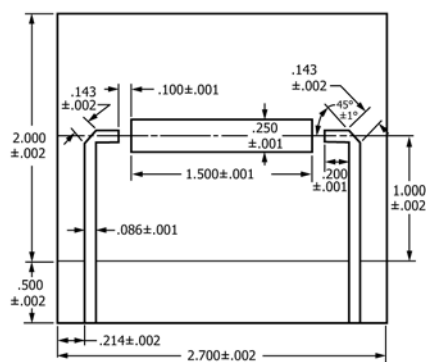

FIG. 3 Enlarged Exploded Side View Sectioned Through a Probe Line Showing Lap Conductor Joint for Fixture A

6.1.1 The Fixture B design has been included since this fixture has been, and still is, in service in numerous laboratories.

6.1.2 The Fixture B design relies upon close control of the room temperature in the laboratory for control of the test specimen temperature.

6.1.3 Changing of test pattern cards in the Fixture B design is less convenient than with the Fixture A design.



in.	mm
0.001	0.03
0.002	0.05
0.086	2.18
0.100	2.54
0.143	3.63
0.200	5.08
0.214	5.44
0.250	6.35
0.500	12.70
1.000	25.40
1.500	38.10
2.000	50.80
2.700	68.58

NOTE 1—Dimensions are in inches.

NOTE 2—Metric equivalents are given for general information only.

FIG. 4 Generalized Resonator Pattern Card for Fixture B Showing Dimensions of Table 1 and Made of Laminate Matching Nominal Permittivity of Material to be Tested

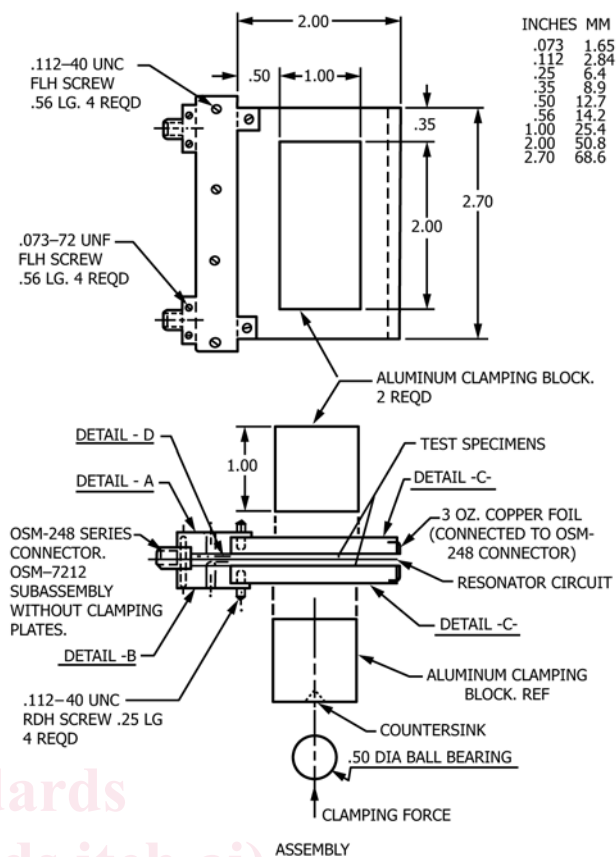

FIG. 5 Test Fixture Construction, Older Design (Fixture B)

6.1.4 For Fixture A, the preferred assembly for Resonator Card and Specimen uses a Lap Conductor Joint. See Fig. 3 for details.

6.2 *Fixture A*—The elements of the fixture include the following:

- 6.2.1 *Resonator Pattern Card* (see Fig. 8),
- 6.2.2 *Base Stripline Board* (see Fig. 9),
- 6.2.3 *Base Cover Board* (see Fig. 10),
- 6.2.4 *End-Launcher Bodies*, adapted (see Fig. 11),
- 6.2.5 *Aluminum Base Plates* (see Fig. 12),
- 6.2.6 *Aluminum Clamping Plates* (see Fig. 13),
- 6.2.7 *Aluminum Blocks*, for temperature control (see Fig. 14), and
- 6.2.8 *Sliders and Blocks* (see Fig. 15).

6.3 *Microwave Signal Source*, capable of providing an accurate signal. An accurate signal provides a leveled power output that falls within a 0.1 dB range during the required time period and over the range of frequency needed to make a permittivity and loss measurement, and maintains output within 5 MHz of the set value for the time required to make a measurement when the signal source is set for a particular frequency.

6.4 *Frequency Measuring Device*, having a resolution 5 MHz or less.

6.5 *Power Level Detecting Device*, having a resolution of 0.1 dB or less and capable of comparing power levels within a 3-dB range with an accuracy of 0.1 dB.

6.6 *Compression Force Gauge*,⁶ capable of measuring to 1100 lb (5000 N) with an accuracy of $\pm 1\%$ of full scale.

6.7 *Vise*, or a press, for exerting a controlled force of 1000 lb (4448 N) on the test fixture and having an opening of at least 5 in. (130 mm) to accept the force gauge and test fixture.

6.8 *Apparatus for Manual Test Setup:*

- 6.8.1 *Sweep Frequency Generator*.^{6,7}
- 6.8.2 *X-Band Frequency Plug-In Unit*.^{6,8}
- 6.8.3 *Frequency Meter*.^{6,9}

⁶ If you are aware of alternative suppliers, please provide this information to ASTM International Headquarters. Your comments will receive careful consideration at a meeting of the responsible technical committee,¹ which you may attend.

⁷ The sole source of supply of the Hewlett Packard (HP) 8350B or 8620C generator known to the committee at this time is Hewlett Packard. If you are aware of alternative suppliers, please provide this information to ASTM International Headquarters. Your comments will receive careful consideration at a meeting of the responsible technical committee,¹ which you may attend.

⁸ The sole source of supply of the Hewlett Packard (HP) 83545A or 86251A plug-in unit known to the committee at this time is Hewlett Packard. If you are aware of alternative suppliers, please provide this information to ASTM International Headquarters. Your comments will receive careful consideration at a meeting of the responsible technical committee,¹ which you may attend.

⁹ The sole source of supply of the Hewlett Packard (HP) X532B meter known to the committee at this time is Hewlett Packard. If you are aware of alternative suppliers, please provide this information to ASTM International Headquarters. Your comments will receive careful consideration at a meeting of the responsible technical committee,¹ which you may attend.

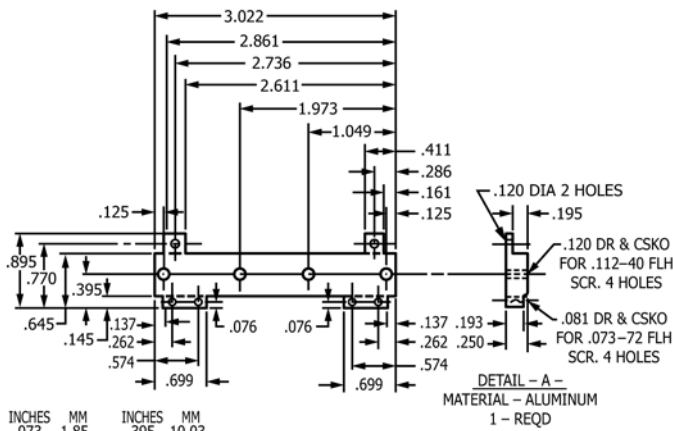

INCHES	MM	INCHES	MM
.073	1.85	.395	10.03
.076	1.93	.411	10.44
.081	2.06	.574	14.58
.112	2.84	.645	16.38
.120	3.05	.699	17.75
.125	3.18	.770	19.56
.137	3.48	.895	22.73
.145	3.68	1.049	26.64
.161	4.09	1.973	50.11
.193	4.90	2.511	66.32
.195	4.95	2.736	69.49
.250	6.35	2.861	72.67
.262	6.65	3.022	76.76
.286	7.26		

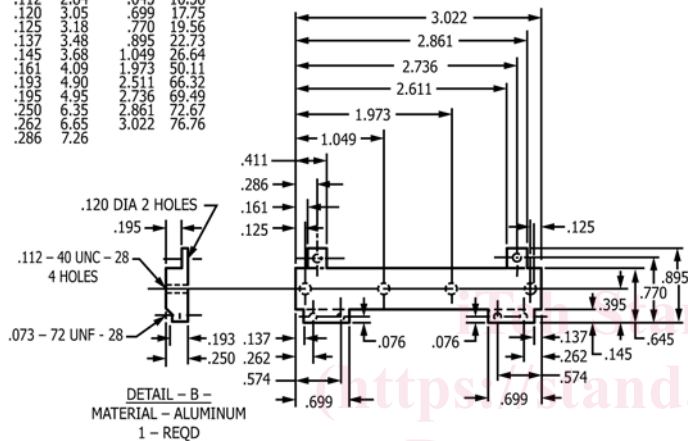
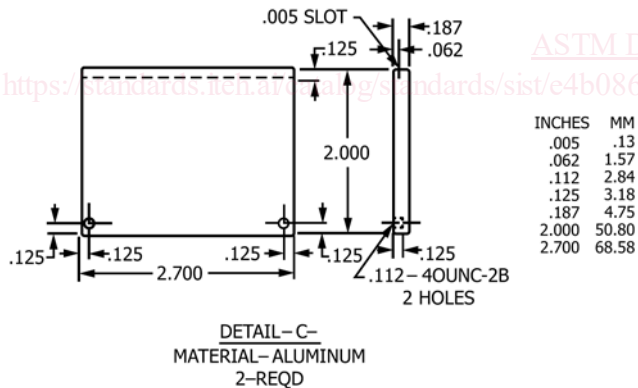
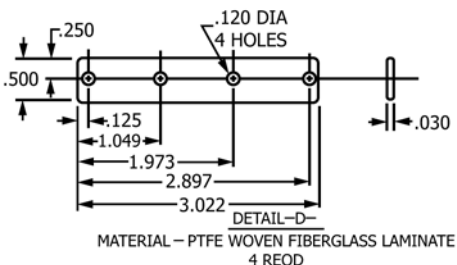

FIG. 6 Test Fixture Construction, Older Design (Fixture B)



INCHES	MM
.005	.13
.062	1.57
.112	2.84
.125	3.18
.187	4.75
2.000	50.80
2.700	68.58



INCHES	MM
.030	.76
.120	3.05
.125	3.18
.250	6.35
.500	12.70
1.049	26.64
1.973	50.11
2.897	73.58
3.022	76.76

FIG. 7 Test Fixture Construction, Older Design (Fixture B)

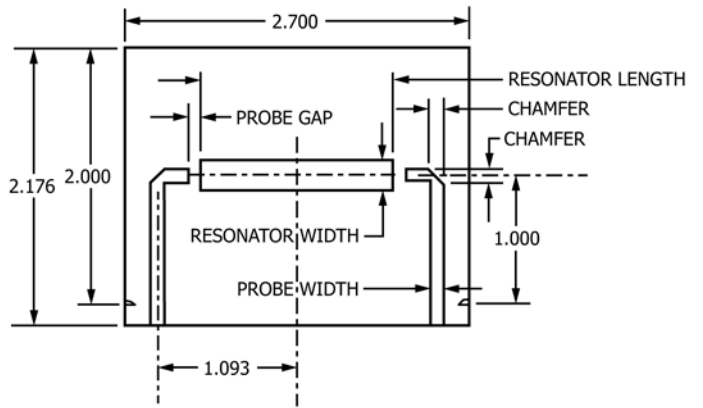

FIG. 8 Generalized Resonator Pattern Card for Fixture A Showing Dimensions of and Made of Laminate Matching Nominal Permittivity of Materials to be Tested

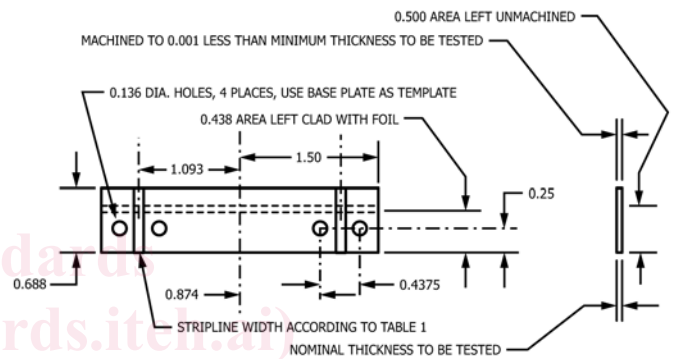

FIG. 9 Base Stripline Board with Copper Foil and Dielectric Matching Nominal Permittivity of Material to be Tested

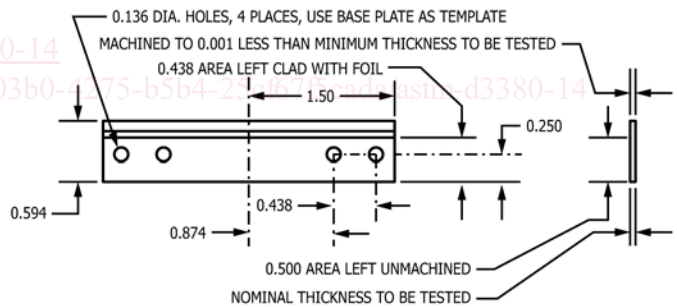

FIG. 10 Base Cover Board with Copper Foil Ground Plane

6.8.4 Crystal Detector;^{6,10} two required.

6.8.5 Matched Load Resistor;^{6,11} for one of the crystal detectors.

¹⁰ The sole source of supply of the Hewlett Packard 423B Neg. detector known to the committee at this time is Hewlett Packard. If you are aware of alternative suppliers, please provide this information to ASTM International Headquarters. Your comments will receive careful consideration at a meeting of the responsible technical committee,¹ which you may attend.

¹¹ The sole source of supply of the Hewlett Packard 11523A option .001 resistor known to the committee at this time is Hewlett Packard. If you are aware of alternative suppliers, please provide this information to ASTM International Headquarters. Your comments will receive careful consideration at a meeting of the responsible technical committee,¹ which you may attend.

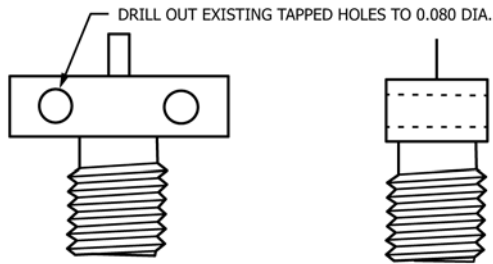

OMNI-SPECTRA MODEL NUMBER 249-25F, OR EQUIVALENT

FIG. 11 Detail of Supplied End Launcher Body Adapted by Boring Out Tapped Holes

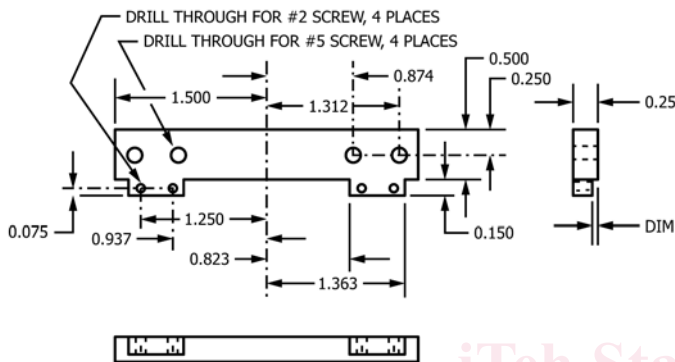

NOTE:
 NOMINAL THICKNESS 0.050 0.062
 DIMENSION 'A' 0.062 0.074

FIG. 12 Aluminum Base Plate for Clamping Base Cards and Connecting Launcher Bodies to Base Card

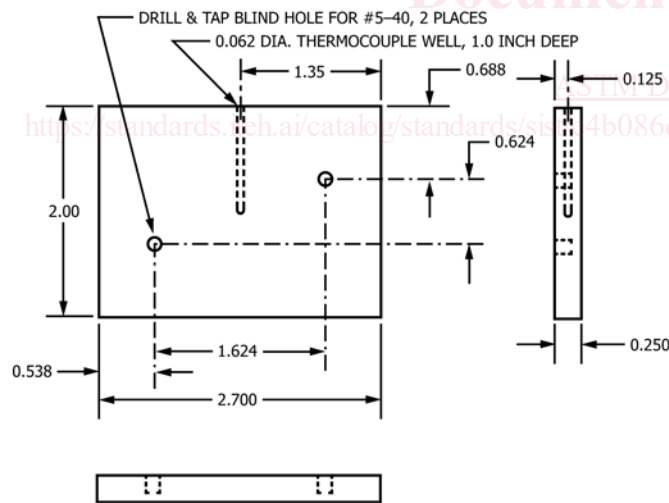

FIG. 13 Aluminum Clamping Plate Provided with Tapped Holes for Pressure Block and Thermocouple Well

6.8.6 Standing Wave Rectified (SWR) Meter,^{6,12} two required.

¹² The sole source of supply of the Hewlett Packard 415E meter known to the committee at this time is Hewlett Packard. If you are aware of alternative suppliers, please provide this information to ASTM International Headquarters. Your comments will receive careful consideration at a meeting of the responsible technical committee,¹ which you may attend.

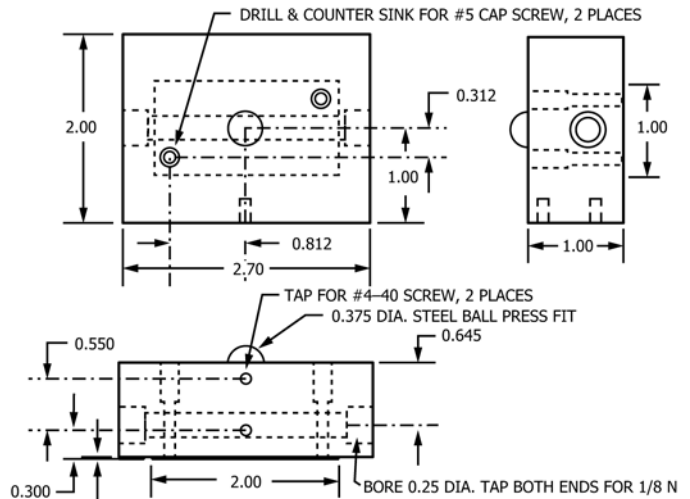
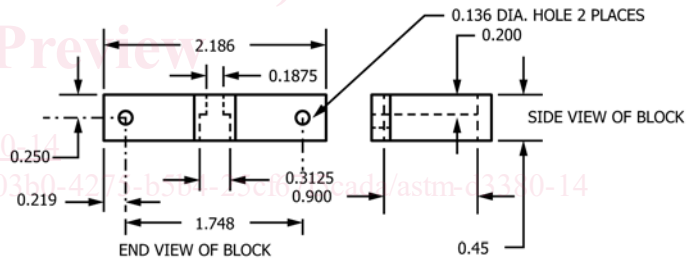
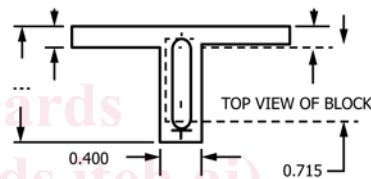

FIG. 14 Aluminum Block for Temperature Control and Transfer of Pressure to Clamp Plates, Fitted with Tapped Holes for Slide, Embedded Steel Ball, and Tapped for Tubing Fittings for Circulating Fluid



WHEN THE SLIDER IS PLACED INSIDE THE BLOCK AND FASTENED TO THE BOTTOM OF THE CLAMP BLOCK IT SHOULD ALLOW TOTAL MOVEMENT OF 0.010 VERTICALLY, 0.020 SIDEWAYS AND 0.10 ALONG THE SLIDER LENGTH

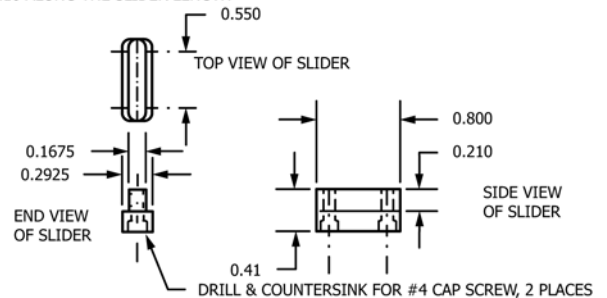

FIG. 15 Slider and Block for Connecting Pressure Block and Base Plate with Allowance for Opening Fixture

6.8.7 *Directional Coupler*.^{6,13}

6.8.8 *Attenuator*.^{6,14} rated at 10 dB.

6.8.9 *Semi-Rigid Coaxial Cable and Connectors*.

6.8.10 *Adapter*.^{6,15} for waveguide to coaxial interconnection.

6.8.11 The assembly of this equipment is shown schematically in Fig. 16.

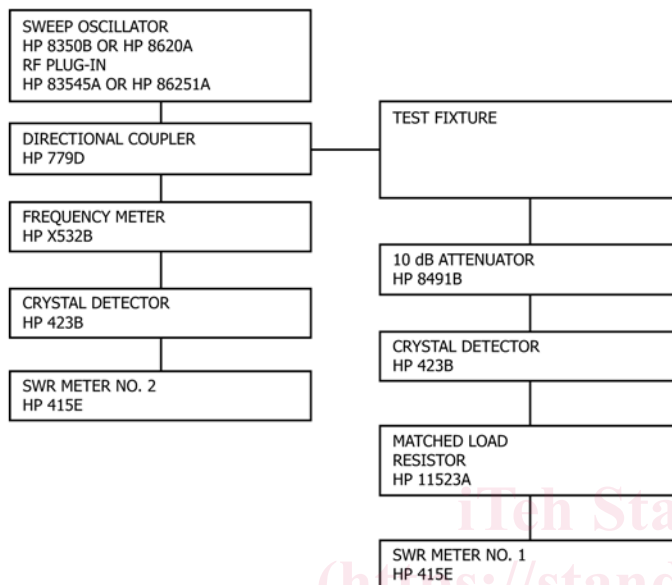

NOTE 1—All coaxial cable connections.

NOTE 2—It is acceptable to substitute equivalent makes and models of equipment where it can be shown that equivalent results are obtained.

NOTE 3—It is acceptable to use alternate test setups provided that equivalent results are obtained.

FIG. 16 X-Band Permittivity Test Setup

6.9 Apparatus for Computer Acquisition of Data—The following alternative equipment or its equivalent, when properly interconnected, has the potential to be used effectively with a computer-control program for automated testing:

6.9.1 *Sweep Frequency Generator*.^{6,16} see also 6.8.1.

6.9.2 *Radio Frequency (RF) Plug-In Unit*.^{6,17} having a range from 0.01 to 20 GHz.

NOTE 3—Significant cost savings are possible if a plug-in of a narrower frequency range (in the X-band from 5.9 to 12.4 GHz) is selected.^{6,18}

6.9.3 *Power Splitter*.^{6,19}

6.9.4 *Automatic Frequency Counter*.^{6,20}

6.9.5 *Source Synchronizer*.^{6,21}

6.9.6 *Attenuator*.^{6,22} 10 dB, see also 6.8.8.

6.9.7 *Programmable Power Meter*.^{6,23}

6.9.8 *Power Sensor*.^{6,24} having a range from -70 to +10 dBm.

6.9.9 *Controlling Computer*, with a General Purpose Interface Bus (GPIB) interface.

6.9.10 *IEEE 488 (GPIB) Cables, Adapters, and Coaxial Cables*, suitable for proper interconnecting of all of the components, as illustrated in Fig. 17 and described in 6.9.11.

6.9.11 *Interconnecting Instructions* (applicable to 6.9 only):

6.9.11.1 Connect the power splitter directly to the RF plug-in output. Connect one output of the splitter to the counter input using an RF cable. With another RF cable, connect the other output to the attenuator. Connect the attenuator to one of the test fixture probe lines.

6.9.11.2 Connect the counter and the synchronizer as specified by the manufacturer of this equipment. Connect the FM

¹⁷ The sole source of supply of the Hewlett Packard plug-in #83592A known to the committee at this time is Hewlett Packard. If you are aware of alternative suppliers, please provide this information to ASTM International Headquarters. Your comments will receive careful consideration at a meeting of the responsible technical committee,¹ which you may attend.

¹⁸ The sole source of supply of the Hewlett Packard plug-in #83545A known to the committee at this time is Hewlett Packard. If you are aware of alternative suppliers, please provide this information to ASTM International Headquarters. Your comments will receive careful consideration at a meeting of the responsible technical committee,¹ which you may attend.

¹⁹ The sole source of supply of the Hewlett Packard power splitter #11667A known to the committee at this time is Hewlett Packard. If you are aware of alternative suppliers, please provide this information to ASTM International Headquarters. Your comments will receive careful consideration at a meeting of the responsible technical committee,¹ which you may attend.

²⁰ The sole source of supply of the Hewlett Packard frequency counter #5343A known to the committee at this time is Hewlett Packard. If you are aware of alternative suppliers, please provide this information to ASTM International Headquarters. Your comments will receive careful consideration at a meeting of the responsible technical committee,¹ which you may attend.

²¹ The sole source of supply of the Hewlett Packard synchronizer #5344A known to the committee at this time is Hewlett Packard. If you are aware of alternative suppliers, please provide this information to ASTM International Headquarters. Your comments will receive careful consideration at a meeting of the responsible technical committee,¹ which you may attend.

²² The sole source of supply of the Hewlett Packard attenuator #8491B known to the committee at this time is Hewlett Packard. If you are aware of alternative suppliers, please provide this information to ASTM International Headquarters. Your comments will receive careful consideration at a meeting of the responsible technical committee,¹ which you may attend.

²³ The sole source of supply of the Hewlett Packard power meter #436A known to the committee at this time is Hewlett Packard. If you are aware of alternative suppliers, please provide this information to ASTM International Headquarters. Your comments will receive careful consideration at a meeting of the responsible technical committee,¹ which you may attend.

²⁴ The sole source of supply of the Hewlett Packard power sensor #8484A known to the committee at this time is Hewlett Packard. If you are aware of alternative suppliers, please provide this information to ASTM International Headquarters. Your comments will receive careful consideration at a meeting of the responsible technical committee,¹ which you may attend.

¹³ The sole source of supply of the Hewlett Packard 779D coupler known to the committee at this time is Hewlett Packard. If you are aware of alternative suppliers, please provide this information to ASTM International Headquarters. Your comments will receive careful consideration at a meeting of the responsible technical committee,¹ which you may attend.

¹⁴ The sole source of supply of the Hewlett Packard attenuator 8491B known to the committee at this time is Hewlett Packard. If you are aware of alternative suppliers, please provide this information to ASTM International Headquarters. Your comments will receive careful consideration at a meeting of the responsible technical committee,¹ which you may attend.

¹⁵ The sole source of supply of the Hewlett Packard adapter X281A known to the committee at this time is Hewlett Packard. If you are aware of alternative suppliers, please provide this information to ASTM International Headquarters. Your comments will receive careful consideration at a meeting of the responsible technical committee,¹ which you may attend.

¹⁶ The sole source of supply of the Hewlett Packard generator 8350B known to the committee at this time is Hewlett Packard. If you are aware of alternative suppliers, please provide this information to ASTM International Headquarters. Your comments will receive careful consideration at a meeting of the responsible technical committee,¹ which you may attend.