



Designation: **B851–04 (Reapproved 2009) B851 – 04 (Reapproved 2014)**

Standard Specification for Automated Controlled Shot Peening of Metallic Articles Prior to Nickel, Autocatalytic Nickel, or Chromium Plating, or as Final Finish¹

This standard is issued under the fixed designation B851; the number immediately following the designation indicates the year of original adoption or, in the case of revision, the year of last revision. A number in parentheses indicates the year of last reapproval. A superscript epsilon (ϵ) indicates an editorial change since the last revision or reapproval.

1. Scope

1.1 This specification covers the requirements for automated, controlled shot peening of metallic articles prior to electrolytic or autocatalytic deposition of nickel or chromium, or as a final finish, using shot made of cast steel, conditioned cut wire, or ceramic media. The process is applicable to those materials on which test work has shown it to be beneficial within given intensity ranges. It is not suitable for brittle materials. Hand peening and rotary flap peening are excluded specifically.

1.2 Shot peening induces residual compressive stresses in the surface and near-surface layers of metallic articles, controlling or limiting the reduction in fatigue properties that occurs from nickel or chromium plating of the article, or the fatigue properties of unplated articles.

1.3 The values stated in SI units are to be regarded as standard. No other units of measurement are included in this standard.

1.4 *This standard does not purport to address all of the safety concerns, if any, associated with its use. It is the responsibility of the user of this standard to establish appropriate safety and health practices and determine the applicability of regulatory limitations prior to use.*

2. Referenced Documents

2.1 ASTM Standards:²

[B183 Practice for Preparation of Low-Carbon Steel for Electroplating](#)

[B242 Guide for Preparation of High-Carbon Steel for Electroplating](#)

[B320 Practice for Preparation of Iron Castings for Electroplating](#)

[B322 Guide for Cleaning Metals Prior to Electroplating](#)

[B607 Specification for Autocatalytic Nickel Boron Coatings for Engineering Use](#)

[B650 Specification for Electrodeposited Engineering Chromium Coatings on Ferrous Substrates](#)

[B656 Guide for Autocatalytic \(Electroless\) Nickel-Phosphorus Deposition on Metals for Engineering Use \(Discontinued 2000\) \(Withdrawn 2000\)](#)³

[B689 Specification for Electroplated Engineering Nickel Coatings](#)

[B733 Specification for Autocatalytic \(Electroless\) Nickel-Phosphorus Coatings on Metal](#)

[E11 Specification for Woven Wire Test Sieve Cloth and Test Sieves](#)

[E165 Practice for Liquid Penetrant Examination for General Industry](#)

[E709 Guide for Magnetic Particle Testing](#)

2.2 Federal Standards:⁴

[QQ-N-290 Nickel Plating \(Electrodeposited\)](#)

[QQ-C-320 Chromium Plating \(Electrodeposited\)](#)

2.3 Military Standards:⁴

[MIL-S-851 Steel Grit, Shot, and Cut Wire Shot, and Iron Grit and Shot Blast Cleaning and Peening](#)

[MIL-S-13165 Shot Peening of Metal Parts](#)

¹ This specification is under the jurisdiction of ASTM Committee B08 on Metallic and Inorganic Coatings and is the direct responsibility of Subcommittee B08.02 on Pre Treatment.

Current edition approved Sept. 1, 2009/Nov. 1, 2014. Published December 2009/November 2014. Originally approved in 1994. Discontinued January 2004 and reinstated in 2004 as B851-04. Last previous edition approved in 2004/2009 as B851-04-09. DOI: 10.1520/B0851-04R09; 10.1520/B0851-04R14.

² For referenced ASTM standards, visit the ASTM website, www.astm.org, or contact ASTM Customer Service at service@astm.org. For *Annual Book of ASTM Standards* volume information, refer to the standard's Document Summary page on the ASTM website.

³ The last approved version of this historical standard is referenced on www.astm.org.

⁴ Available from Standardization Documents Order Desk, Bldg. 4 Section D, 700 Robbins Ave., Philadelphia, PA 19111-5094, Attn: NPODS.

MIL-C-26074 Coating, Electroless Nickel
 MIL-STD-45662 Calibration System Requirements

2.4 SAE Standards:⁵

SAE J441 Cut Steel Wire Shot

SAE J442 Test Strip, Holder and Gage for Shot Peening

SEA J827 Cast Steel Shot

SAE J1830 Size, Classification and Characteristics of Ceramic Shot for Peening

3. Terminology

3.1 Definitions:

3.1.1 *Almen strip*—UNS G10700 carbon steel specimens that are used to calibrate the energy of a shot peening stream (see Fig. 1).

3.1.2 *Almen strip holding fixture*—a fixture for holding Almen strips in suitable locations that represent the position and angular orientation of the surfaces of a part where intensity is to be determined and verified (see Fig. 2).

3.1.3 *arc height*—flat Almen strips, when subjected to a stream of shot moving at an adequate velocity, bending in an arc corresponding to the amount of energy transmitted by the shot stream. The height of the curved arc measured in millimeters is the arc height, measured by an Almen gage (see Fig. 3).

⁵ Available from Society of Automotive Engineers, 400 Commonwealth Drive, Warrendale, PA 15096.

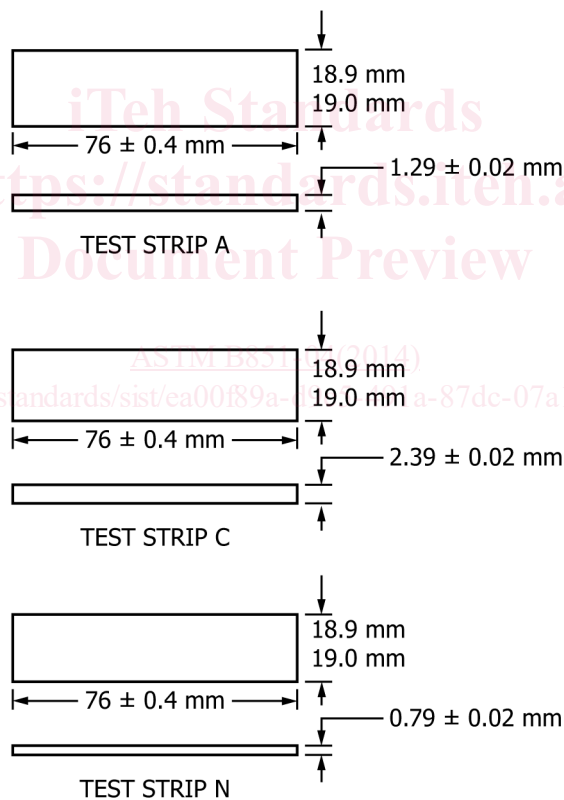

TEST STRIP SPECIFICATIONS

Analysis of stock - UNS G10700
 Cold rolled spring steel
 Square edge number one (on 76.2 mm edge)
 Finish - blue temper (or bright)
 Uniformly hardened tempered to 44 - 50 HRC
 Flatness C ± 0.038 mm arc height
 Flatness N and A ± 0.025 mm arc height

FIG. 1 Almen Test Specimen

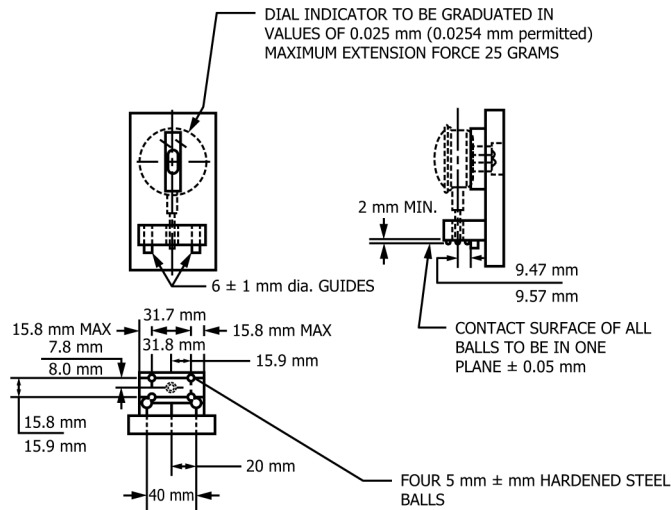

FIG. 2 Assembled Test Strip and Holder

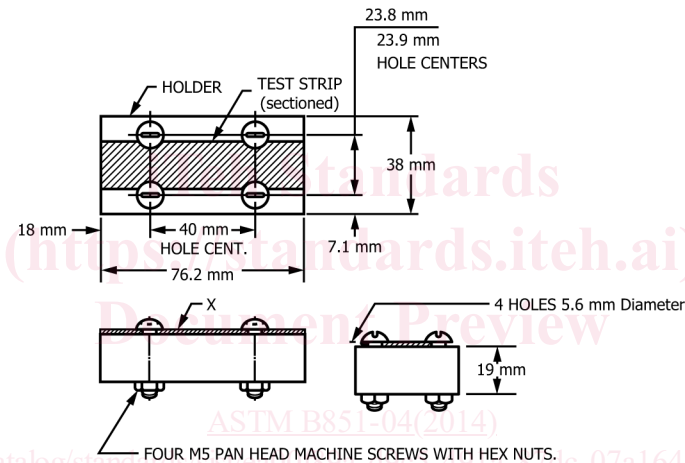

FIG. 3 Almen Gage

3.1.4 *automatic equipment*—shot peening equipment in which parts, fixtures, nozzles, and peening parameters are preset by hand or by locating fixtures and verified by inspection personnel. The peening time is monitored automatically, and the air pressure or wheel speed is set manually.

3.1.5 *compressive stresses*—cold working or stretching the surface beyond the elastic limit by shot peening, creating a layer in compression below the surface. The depth of compressive stresses is measured by the crown of the dimple to the depth.

3.1.6 *coverage*—the extent of obliteration of the original surface by dimples produced by impact from individual shot particles and expressed as a percentage. See [Note 1](#).

3.1.7 *depth of compressive stresses*—where the stress profile passes through 0 stress.

3.1.8 *intensity*—the Almen strip arc height at saturation. Arc height is not termed intensity correctly unless saturation is achieved.

3.1.9 *liquid tracer system*—a liquid coating material bearing a pigment that fluoresces under an ultraviolet light and removes at a rate proportioned to peening coverage.

3.1.10 *microprocessor-controlled equipment*—peening equipment that has nozzle holding fixtures and is computer controlled for processing, monitoring, and documentation of the peening parameters critical to process certification.

3.1.11 *nozzle holding fixture*—a fixture that holds the nozzles at the required location, distance, and angle in a locked position during the peening operation.

3.1.12 *process interrupt parameters*—for critical peening operations, parameters such as shot flow, air pressure, part r/min, oscillation rate, and cycle time that must be monitored within process requirements.

3.1.13 *saturation*—the minimum duration of peening necessary to achieve the desired Almen intensity which, when doubled, does not increase the Almen strip arc height by more than 10 %.

3.1.14 *saturation curve*—a curve that plots peening time on the Almen strip (abscissa) versus Almen strip arc height (ordinate) achieved for the peening time (see Fig. 4).

3.1.15 *surface obliteration*—the condition of a peened surface in which 100 % of the surface has been dimpled with shot impressions.

NOTE 1—A 100 % coverage is defined as that leaving unpeened 2 % or less of the original surface because the estimation of coverage of the impressions is difficult when this is approximately 98 % of the total surface. The 100 % coverage is a theoretical limiting value. Hence, the term complete coverage is preferred. Complete coverage usually requires increasing the base time, that is, the time of peening to reach 98 % coverage, by 15 to 20 %. Values of 200 %, 300 %, etc. are obtained by multiplying this run time by 2, 3, etc.

4. Ordering Information

- 4.1 When ordering articles to be shot peened, the purchaser shall state the following:
 - 4.2 ASTM designation.
 - 4.3 Type, size, and hardness of shot to be used (see 6.1).
 - 4.4 Number and frequency of the determinations of shot size and uniformity required, if other than those specified in 8.1.1.
 - 4.5 Peening intensity to be used at each location (see 8.2).
 - 4.6 Number, frequency, and locations of Almen test specimens to be provided for intensity verification and monitoring of the process if other than those specified in 8.2, 8.2.1, and 8.2.2.
 - 4.7 Areas on the part that are to be shot peened and those to be protected from the peening (see 7.5).
 - 4.8 Whether magnetic particle or penetrant inspection is required before peening (see 7.2).
 - 4.9 Amount (percent) of coverage required in the areas to be peened. A complete coverage is the minimum requirement (see 3.1.6 and 8.3).
 - 4.10 Method for measuring coverage (see 8.3.1).
 - 4.11 Type of equipment to be used, automated or computer-monitored microprocessor (see 6.3 and X1.10 – X1.12).
 - 4.12 Details of any post treatment such as corrosion protection (see 9.5).
 - 4.13 Requirements of certification and test records, as specified in Section 10.

5. Significance and Use

5.1 Shot peening is a process for cold working surfaces by bombarding the product with shot of a solid and spherical nature propelled at a relatively high velocity. In general, shot peening will increase the fatigue life of a product that is subject to bending or torsional stress. It will improve resistance to stress corrosion cracking. It can be used to form parts or correct their shapes. See Appendix X1 for additional information.

5.2 It is essential that the shot peening process parameters be controlled rigidly to ensure repeatability from part to part and lot to lot.

5.3 This specification covers techniques and methods necessary for proper control of the shot peening process.

6. Materials and Equipment

6.1 *Shot Material Composition:*

6.1.1 *Cast Steel*—Cast steel shot shall conform to the requirements of SAE J827.

6.1.2 *Cut Wire*—Cut wire shot shall be made from cold finished, round wire, conforming to SAE J441.

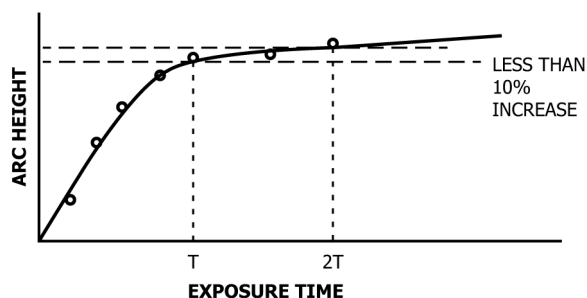

FIG. 4 Saturation Curve

6.1.3 *Ceramic Shot*—Ceramic beads shall conform to the chemical composition given in [Table 1](#) and to SAE J1830.

6.1.4 *Shot Form and Shape*:

6.1.4.1 *Cast Steel*—Cast steel shot shall be spherical in shape and free of sharp edges, corners, and broken pieces. It shall conform to the acceptable shapes given in [Fig. 5](#). The number of nonconforming shapes (see [Fig. 6](#)) shall not exceed the values given in [Table 2](#).

6.1.4.2 *Cut Wire*—Cut wire shot shall be spherical in shape. It shall be free of sharp edges, corners, and broken pieces. The number of nonconforming shapes shall not exceed the values given in [Table 2](#).

6.1.4.3 *Ceramic Shot*—Ceramic shot shall be spherical in shape and free of sharp edges, corners, and broken pieces. The number of nonconforming shapes shall not exceed the values given in [Table 2](#).

6.1.5 *Hardness*—The hardness of the media shall exceed that of the material to be processed.

6.1.5.1 *Cast Steel*—Cast steel shot shall have a hardness of HR_c 45 to HR_c 55. Special hard cast steel shot shall be used on products harder than HR_c 50 and shall have a hardness of HR_c 55 to HR_c 65.

6.1.5.2 *Cut Wire*—Cut wire shot shall have a hardness equal to or greater than that given in [Table 3](#).

6.1.5.3 *Ceramic Shot*—Ceramic shot shall have a minimum hardness of 560 HV₃₀ (30 kgf).

6.1.6 *Size*:

(1) The size of the media shall be capable of producing the required intensity in the required time.

(2) If a peened surface contains a fillet, the nominal size of the shot shall not exceed one-half of the radius of the fillet.

(3) If the shot must pass through an opening, such as a slot, to reach a peened surface the nominal diameter of the shot shall not exceed one-fourth of the width or the diameter of the opening.

6.1.6.1 *Cast Steel*—Cast steel shot charged into a machine shall conform to the screen requirements given in [Table 4](#) for the nominal size selected. When a machine has a completely new charge of cast steel shot, conditioning shall be conducted, to remove the oxide layers on the shots, by bombarding onto a hardened steel surface for a minimum of two passes. Conditioning may not be required if the addition to the charge already in the machine is below 25 %. If the addition of over 25 % is made to the charge, conditioning is required.

6.1.6.2 *Cut Wire*—The diameter of cut wire shot charged into a machine shall conform to the requirements given in [Table 4](#). Cut wire shot shall conform to the requirements of length and cumulative weight given in [Table 5](#). It is mandatory that only preconditioned cut wire shot be used.

6.1.6.3 *Ceramic Shot*—Ceramic shot charged into the peening machine shall conform to the screen requirements of [Table 6](#).

6.2 *Almen Strips, Blocks, and Gages*—Almen strips, blocks, and gages used shall meet the requirements of SAE J442.

6.3 *Equipment*—Shot peening shall be conducted in a machine that is designed for the purpose, propels shot at high speed against the product, moves the product through the shot stream in a way that ensures complete and uniform peening, and screens the shot continuously to remove broken or defective shot.

7. Pre-Peening Treatment

7.1 *Prior Operations*—Areas of parts to be shot peened shall be within dimensional requirements before peening. Except as otherwise permitted, all heat treatment, machining, and grinding shall be completed before shot peening. All fillets shall be formed, all burrs removed, and all sharp edges and corners that require peening provided with sufficient radii prior to peening, in order to result in complete coverage without any distortion, chipping, or rollover.

7.2 *Flaw and Crack Testing*—When required, magnetic particle, penetrant, ultrasonic, or other flaw or crack detection processes shall be completed prior to peening. See Test Method [E165](#) and Guide [E709](#).

7.3 *Corrosion and Damage*—Parts shall not be peened if they show evidence of invasive corrosion or mechanical damage on the surface.

7.4 *Cleaning*—Cleaning prior to peening shall be accomplished by vapor degreasing, solvent wiping, warm solvent spray, or an acceptable water-base nonflammable product, as required, to remove all soils, scale, and coatings from the surface areas to be peened. See Practices [B183](#), [B242](#), [B320](#), and [B322](#).

7.5 *Masking*—Surfaces designated on the drawing to be free of shot peening marks shall be masked or otherwise protected from the shot stream or indirect impingement by shot.

7.5.1 Suitable masking materials are adhesive tape, sheet rubber, etc. If adhesive tape is used, it shall be coated on one face with adhesive, and when the tape is removed from the surface it shall not show any evidence of corrosion or leave any residue on the surface. Areas not requiring peening and not required to be masked shall be considered optional.

TABLE 1 Composition of Ceramic Shot

ZrO ₂ , %	SiO ₂ , %	Al ₂ O ₃ , %	Fe ₂ O ₃ , %	Free Iron, %	Specific Gravity, g/cm ³
60.0–70.0	28.0–33.0	10.0 max	0.1 max	0.1 max	3.60–3.95

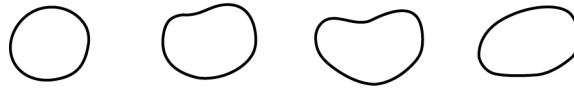

Not necessarily spheres but all corners rounded.

FIG. 5 Acceptable Shapes

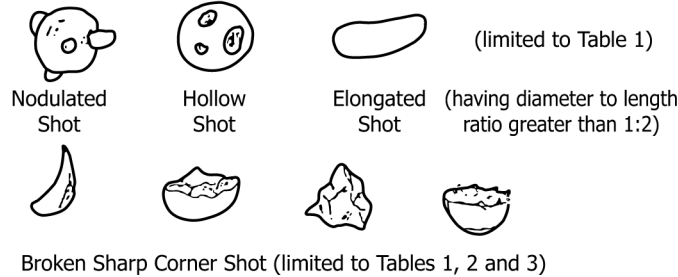

FIG. 6 Unacceptable Shapes

TABLE 2 Maximum Allowable Nonconforming Shapes—Cast Steel, Cut Wire, and Ceramic Shot (in accordance with Fig. 6)

Cast Steel Size	Cut Wire Size	Ceramic Size	Maximum Allowable Nonconforming Shapes per area 1 cm x 1 cm
930			5
780			5
660	CW62		12
550	CW54		12
460	CW47		15
390	CW41		80
	CW35		80
330	CW32	Z850	80
280	CW28		80
230	CW23	Z600	80
190	CW20		80
170		Z425	80
130			480
110		Z300	640
70		Z210	640

TABLE 3 Hardness Cut Wire Shot

Cut Steel Wire Shot (Shall Have the Following Minimum Hardness)	
Shot Size	Minimum Hardness, Rockwell C
CW 62	36
CW 54	39
CW 47	41
CW 41	42
CW 35	44
CW 32	45
CW 28	46
CW 23 and finer	48

8. Procedure

8.1 *Shot*—Shot charged into the peening machine shall be as specified by the purchaser and meet the requirements of 6.1 for the particular type, size, and material required. Unless otherwise specified, all shot shall be maintained in the machine so that it conforms to the requirements of Table 7.

8.1.1 *Uniformity Determination*—At least one determination for shot size and uniformity in accordance with Table 7 shall be made before and after each production run and after each 8 h of production on long runs, when using cast or cut wire steel shot. Ceramic shot size distribution shall be verified at least every 4 h of production and before and after each production run.

8.2 *Peening Intensity*—The peening intensity should be that specified by the purchaser as the arc height produced by the peening process at saturation, as measured on Almen strips placed in the required locations. Unless otherwise specified on the drawing or in the contract, the intensity of peening shall be as specified in Table 8 for the thickness involved.