

INTERNATIONAL
STANDARD

22
ISO
3537

Second edition
1993-07-01

**Road vehicles — Safety glazing materials —
Mechanical tests**

Véhicules routiers — Vitrages de sécurité — Essais mécaniques

iTeh STANDARD PREVIEW
(standards.iteh.ai)

ISO 3537:1993

<https://standards.iteh.ai/catalog/standards/sist/da448fd3-a7d5-43b3-8eae-a7e28cdda482/iso-3537-1993>



Reference number
ISO 3537:1993(E)

Foreword

ISO (the International Organization for Standardization) is a worldwide federation of national standards bodies (ISO member bodies). The work of preparing International Standards is normally carried out through ISO technical committees. Each member body interested in a subject for which a technical committee has been established has the right to be represented on that committee. International organizations, governmental and non-governmental, in liaison with ISO, also take part in the work. ISO collaborates closely with the International Electrotechnical Commission (IEC) on all matters of electrotechnical standardization.

Draft International Standards adopted by the technical committees are circulated to the member bodies for voting. Publication as an International Standard requires approval by at least 75 % of the member bodies casting a vote.

International Standard ISO 3537 was prepared by Technical Committee ISO/TC 22, *Road vehicles*, Sub-Committee SC 11, *Safety glazing materials*.

ISO 3537:1993

This second edition ~~replaces and cancels the first edition~~ (ISO 3537:1975), of which it constitutes a technical revision.

© ISO 1993

All rights reserved. No part of this publication may be reproduced or utilized in any form or by any means, electronic or mechanical, including photocopying and microfilm, without permission in writing from the publisher.

International Organization for Standardization

Case Postale 56 • CH-1211 Genève 20 • Switzerland

Printed in Switzerland

Road vehicles — Safety glazing materials — Mechanical tests

1 Scope

This International Standard specifies mechanical test methods relating to the safety requirements for all safety glazing materials in a road vehicle, whatever the type of glass or other material of which they are composed. Terms used are in accordance with ISO 3536.

2 Normative references

The following standards contain provisions which, through reference in this text, constitute provisions of this International Standard. At the time of publication, the editions indicated were valid. All standards are subject to revision, and parties to agreements based on this International Standard are encouraged to investigate the possibility of applying the most recent editions of the standards indicated below. Members of IEC and ISO maintain registers of currently valid International Standards.

ISO 48:1979, *Vulcanized rubbers — Determination of hardness (Hardness between 30 and 85 IRHD)*.

ISO 3536:1992, *Road vehicles — Safety glazing materials — Vocabulary*.

3 Test conditions

Unless otherwise specified, the tests shall be carried out under the following conditions:

Ambient temperature: $20\text{ °C} \pm 5\text{ °C}$

Atmospheric pressure: 86 kPa to 106 kPa
(860 mbar to 1 060 mbar)

Relative humidity: $(60 \pm 20)\%$

4 Application of tests

For certain types of safety glazing materials, it is not necessary to carry out all the tests specified in this International Standard, when the results, according

to the purpose of testing, can be predicted with certainty from knowledge of the properties of the safety glazing material concerned.

5 227 g ball test

5.1 Principle

Determination of whether the safety glazing material has a certain minimum strength and cohesion under impact from a small hard object.

5.2 Apparatus

5.2.1 Hardened steel ball, with a mass of $227\text{ g} \pm 2\text{ g}$ and a diameter of approximately 38 mm.

5.2.2 Means for dropping the ball freely from a height to be specified, or **means for giving the ball a velocity equivalent to that obtained by the free fall**.

When a device to project the ball is used, the tolerance on velocity shall be $\pm 1\%$ of the velocity equivalent to that obtained by the free fall.

5.2.3 Supporting fixture, such as that shown in figure 1, composed of two steel frames, with machined borders, 15 mm wide, fitting one over the other and faced with rubber gaskets about 3 mm thick and 15 mm wide, of hardness 50 IRHD, determined in accordance with ISO 48.

The lower frame rests on a steel box, about 150 mm high. The test piece is held in place by the upper frame, the mass of which is about 3 kg. The supporting frame is welded on a sheet of steel about 12 mm thick, resting on the floor, with an interposed sheet of rubber, about 3 mm thick, of hardness 50 IRHD.

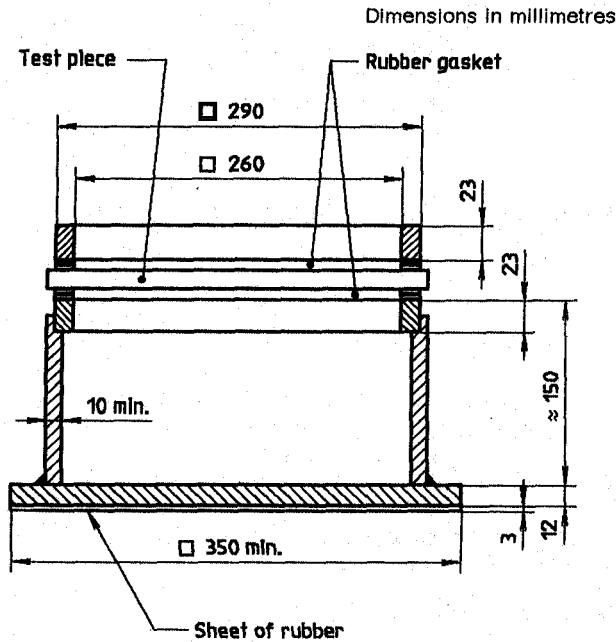

Figure 1 — Support for ball tests

5.3 Test piece

The test piece shall be a flat square with 3537:1993
300 mm ⁺¹⁰₀ mm sides.

5.4 Procedure

Condition the test piece at the specified temperature for at least 4 h immediately preceding the test.

Place the test piece in the fixture (5.2.3). The plane of the test piece shall be perpendicular, within 3°, to the incident direction of the ball. When necessary to retain the test piece in the fixture, it shall be clamped to ensure that the movement of the test piece during test will not exceed 2 mm at any point along the inside periphery of the fixture.

The point of impact shall be within 25 mm of the geometric centre of the test piece for a drop height less than or equal to 6 m, and within 50 mm of the centre of the test piece for a drop height greater than 6 m.

The ball shall strike the face of the test piece which represents the outside face of the safety glazing material when mounted on the vehicle. The ball shall be allowed to make only one impact.

5.5 Expression of results

Assess the type and extent of damage to the test piece. If fragments are detached from the test piece,

the total mass of the fragments and the mass of the largest fragment, detached from the side remote from impact, shall be weighed to the nearest 0,1 g.

6 2 260 g ball test

6.1 Principle

Evaluation of the penetration resistance of the safety glazing material.

6.2 Apparatus

6.2.1 **Hardened steel ball**, with a mass of 2 260 g ± 20 g and a diameter of approximately 82 mm.

6.2.2 **Means for dropping the ball** freely from a height to be specified, or **means for giving the ball a velocity equivalent to that obtained by the free fall.**

When a device to project the ball is used, the tolerance on velocity shall be ± 1 % of the velocity equivalent to that obtained by the free fall.

6.2.3 **Supporting fixture**, as described in 5.2.3.

6.3 Test piece

The test piece shall be a flat square with 300 mm ⁺¹⁰₀ mm sides or shall be cut out from the flattest part of a windscreen or other curved safety glazing material.

Alternatively, the whole windscreen or other curved safety glazing material may be tested. In this case, care shall be taken to ensure adequate contact between the safety glazing material and the support.

6.4 Procedure

Condition the test piece at the specified temperature for at least 4 h immediately preceding the test.

Place the test piece in the fixture (6.2.3). The plane of the test piece shall be perpendicular, within 3°, to the incident direction of the ball. When necessary to retain the test piece in the fixture, the test piece in the fixture shall be clamped to ensure that the movement of the test piece during test will not exceed 2 mm at any point along the inside periphery of the fixture.

The point of impact shall be within 25 mm of the geometric centre of the test piece. The ball shall strike the face of the test piece which represents the internal face of the safety glazing material when mounted on the vehicle. The ball shall be allowed to make only one impact.

6.5 Expression of results

If the ball passes completely through the test piece within 5 s after the impact, the result shall be recorded as a "penetration". If the ball remains on top of the test piece, or wedged in a hole, for 5 s or more, the result shall be recorded as a "support".

7 Abrasion test

7.1 Principle

Determination of whether the safety glazing material has a certain minimum resistance to abrasion.

7.2 Apparatus

7.2.1 Abrading instrument,¹⁾ shown diagrammatically in figure 2, and consisting of

- a horizontal turntable and centre clamp which revolves counter-clockwise at 55 r/min to 75 r/min;
- two weighted parallel arms, each carrying a special abrasive wheel freely rotating on a ball bearing horizontal spindle; each rests on the test specimen under the pressure exerted by a mass of 500 g.

The turntable of the abrading instrument shall rotate regularly, substantially in one plane (the deviation from this plane shall not be greater than $\pm 0,05$ mm at a distance of 1,6 mm from the turntable periphery).

The wheels shall be mounted in such a way that when they are in contact with the rotating test piece, they rotate in contrary directions so as to exert a compressive and abrasive action along curved lines over an annular area of about 30 cm^2 , twice during each rotation of the test piece.

1) A suitable abrading instrument is supplied by Teledyne Taber (USA).

This information is given for the convenience for users of this International Standard and does not constitute an endorsement by ISO of the product named. Equivalent products may be used if they can be shown to lead to the same results.

2) Suitable abrasive wheels may be obtained from Teledyne Taber (USA).

This information is given for the convenience for users of this International Standard and does not constitute an endorsement by ISO of the product named. Equivalent products may be used if they can be shown to lead to the same results.

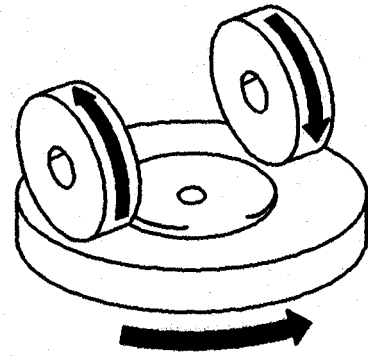

Figure 2 — Diagram of abrading instrument

7.2.2 Abrasive wheels,²⁾ each 45 mm to 50 mm in diameter and 12,5 mm thick, composed of special finely screened abrasive embedded in a medium-hard rubber. The wheels shall have a hardness of $72 \text{ IRHD} \pm 5 \text{ IRHD}$ measured at four points equally spaced on the centreline of the abrading surface with the pressure directly applied vertically along a diameter of the wheel, the readings being taken 10 s after full application of pressure.

The abrasive wheels shall be prepared for use by very slow rotation against a sheet of flat glass.

7.2.3 Light source, consisting of an incandescent lamp, the filament of which is contained within a parallelepiped $1,5 \text{ mm} \times 1,5 \text{ mm} \times 3 \text{ mm}$. The voltage at the lamp terminals shall be such that the colour temperature is $2\,856 \text{ K} \pm 50 \text{ K}$. This voltage shall be stabilized within $1/1\,000$. The instrument used to check the voltage shall be of appropriate accuracy for this application.

7.2.4 Optical system, consisting of a lens corrected for chromatic aberrations. The clear aperture of the lens shall not exceed $f/20$. The distance between the lens and the light source shall be adjusted in order to obtain a light beam which is substantially parallel.

A diaphragm shall be inserted to limit the diameter of the light beam to $7 \text{ mm} \pm 1 \text{ mm}$. This diaphragm shall be situated at a distance of $100 \text{ mm} \pm 50 \text{ mm}$ from the lens on the side remote from the light source.

7.2.5 Equipment for measuring scattered light (see figure 3), consisting of photoelectric cell with an integrating sphere of diameter 200 mm to 250 mm. The sphere shall be equipped with entrance and exit ports for the light. The entrance port shall be circular and have a diameter at least twice that of the light beam. The exit port of the sphere is provided with a light-trap or a reflectance standard respectively according to the procedure described in 7.4.3. The light-trap shall absorb the light when no test piece is inserted in the light beam.

The axis of the light beam shall pass through the centre of the entrance and exit ports. The diameter b of the light exit port shall be equal to $2a \tan 4^\circ$, where a is the diameter of the sphere.

The photoelectric cell shall be mounted in such a way that it cannot be reached by light coming directly from the entrance port or from the reflectance standard.

The surfaces of the interior of the integrating sphere and the reflectance standard shall be of substantially equal reflectance and shall be matt and non-selective.

The output of the photoelectric cell shall be linear within $\pm 2\%$ over the range of luminous intensity used. The design of the instrument shall be such that there is no galvanometer deflection when the sphere is dark.

The whole apparatus shall be checked at regular intervals by means of calibration standards of defined haze.

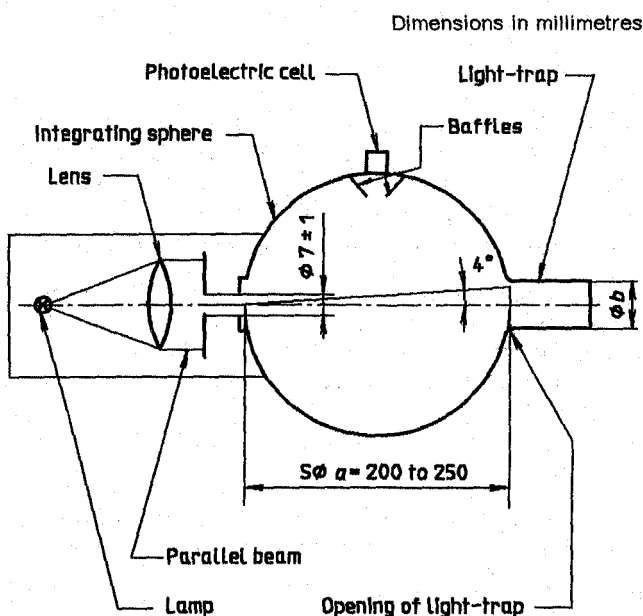

Figure 3 — Hazemeter

If haze measurements are made using equipment or methods differing from the above, the results shall be corrected in order to be in agreement with those obtained by the apparatus described above.

7.3 Test pieces

The test pieces shall be flat squares with 100 mm sides having both surfaces substantially plane and parallel, and optionally with a 6,3 mm diameter fixing hole drilled in the centre.

7.4 Procedure

The abrasion test shall be carried out on both inside and outside surfaces of the safety glazing material except in the case where both surfaces are comprised of glass. In this case they shall be carried out only on the outside surface.

7.4.1 Immediately before and after the abrasion, clean the test pieces in the following manner:

- wipe with a linen cloth under clean running water;
- rinse with distilled or demineralized water;
- blow dry with air or nitrogen;
- remove possible traces of water by dabbing softly with a damp linen cloth. If necessary, dry by pressing lightly between two linen cloths.

Any treatment with ultra-sonic equipment shall be avoided.

After cleaning, the test pieces shall be handled only by their edges and shall be stored to prevent damage to, or contamination of, their surfaces.

7.4.2 When testing glass surfaces of safety glazing materials, condition the test pieces prior to testing for a minimum of 48 h at $20^\circ\text{C} \pm 5^\circ\text{C}$ and $(60 \pm 20)\%$ relative humidity.

When testing plastics surfaces of safety glazing materials, condition the test pieces for a minimum of 48 h at $23^\circ\text{C} \pm 2^\circ\text{C}$ and $(50 \pm 5)\%$ relative humidity.

Condition the abrasive wheels, prior to testing, for a minimum of 48 h at the same conditions of temperature and relative humidity as the samples to be tested.

7.4.3 Immediately place the test piece against the entrance port of the integrating sphere. The angle between the normal to the surface of the test piece and the axis of the beam shall not exceed 8° .

Take the four readings indicated in table 1.

Table 1

Reading	With test piece	With light-trap	With reflectance standard	Quantity represented
τ_1	No	No	Yes	Incident light
τ_2	Yes	No	Yes	Total light transmitted by test piece
τ_3	No	Yes	No	Light scattered by instrument
τ_4	Yes	Yes	No	Light scattered by instrument and test piece

Repeat readings for τ_1 , τ_2 , τ_3 and τ_4 with additional specified positions of the test piece to determine uniformity.

Calculate the total transmittance:

$$\tau_t = \tau_2 / \tau_1 \quad \dots (1)$$

Calculate the diffuse transmittance τ_d as follows:

$$\tau_d = \frac{\tau_4 - \tau_3(\tau_2 / \tau_1)}{\tau_1 - \tau_3} \quad \dots (2)$$

Calculate the percentage haze, or light, or both, scattered as follows:

$$\frac{\tau_d}{\tau_t} \times 100 \quad \dots (3)$$

Calculate the initial haze of the test piece at a minimum of four equally spaced points in the unabraded area in accordance with formula (3). Average the results for each test piece. In lieu of the four measurements, an average value may be obtained by rotating the piece uniformly at 3 r/s or more.

For each safety glazing material, carry out three tests with the same load. For outside surfaces, use the haze as a measure of the subsurface abrasion after the test piece has been subjected to the abrasion test for 1 000 cycles. Simulate the surface abrasion by subjecting the test specimen to the abrasion test for 100 cycles.

For inside surfaces, subject the test piece to 100 test cycles to measure surface abrasion.

The abrasion test of safety glazing material shall be carried out under the same conditions as those

which were used to condition the test specimens and abrasive wheels prior to the abrasion test.

Measure the light scattered by the abraded track at a minimum of four equally spaced points along the track in accordance with formula (3). Average the results for each test piece. In lieu of the four measurements, an average value may be obtained by rotating the piece uniformly at 3 r/s or more.

7.5 Expression of results

Subtract the average initial haze from the average total light scattered, the difference representing the light scatter resulting from abrading the test piece. Also calculate this difference for the surface abrasion and subsurface abrasion.

8 Fragmentation test

8.1 Principle

Assessment of the ability of fragments of safety glazing material to cause injury in the event of fracture.

8.2 Apparatus

Instrument capable of causing the glazing material to break from the impacted surface, such as a hammer with a pointed head or an automatic punch.

8.3 Procedure

Fix the test piece tightly on top of second test piece of the same shape and dimensions by means of transparent adhesive tape on the periphery, placing a piece of photographic paper between the test pieces.

The exposure of the photographic paper shall start not later than 10 s after the impact and terminate not later than 3 min after it. Only the deepest lines, representing the initial fracture, shall be taken into consideration.

The impact points shall be situated as follows (see the examples in figure 4):

Point 1, 30 mm from the edge in one corner (in the sharpest corner, for irregularly shaped safety glazing materials).

Point 2, 30 mm from the nearest edge, on one of the medians.

Point 3, at the geometrical centre of the test piece, or, in the case of windscreens, at the centre of the primary vision area.

Point 4, for curved safety glazing materials, on the longest median at a point of maximum curvature. For curved safety glazing materials, the impacts shall be made from the convex side, or, if necessary, from the concave side.

8.4 Expression of results

Evaluate the ability of fragments of safety glazing material to cause injury by reference to their size,

shape, mass and distribution by inspection of the photographic record.

9 Head-form test

9.1 Principle

Assessment of the minimum strength and cohesion of the safety glazing material under impact from a blunt, bulky object. If required, tests can be performed on whole windscreens.

Dimensions in millimetres

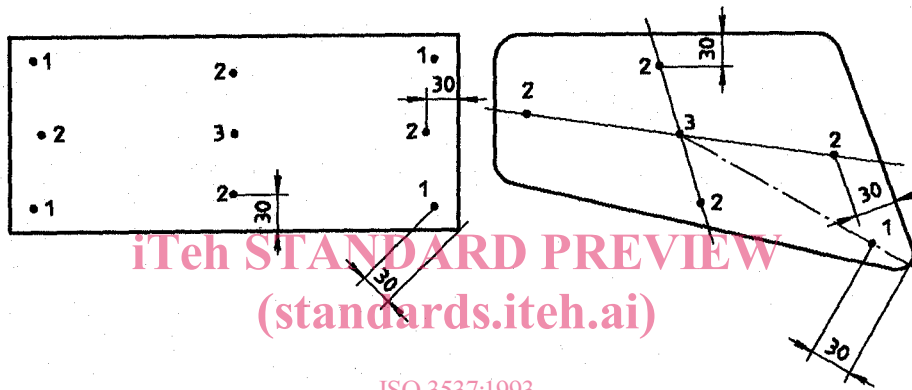

a) Flat or cylindrically curved safety glazing materials
<https://standards.iteh.ai/catalog/standards/sist/da448d5-a7d5-4363-8eac-a7e28cdda482/iso-3537-1993>

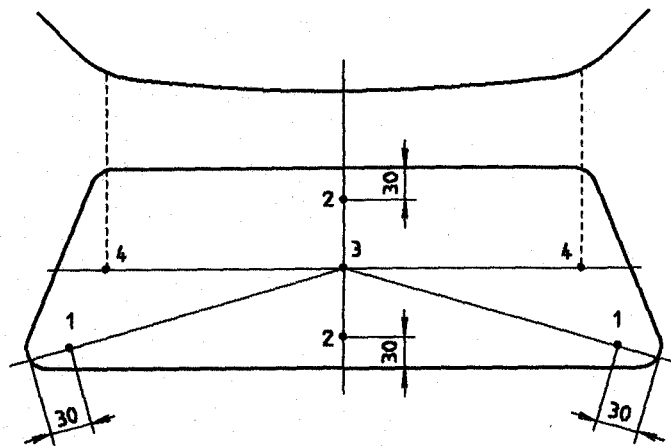

b) Complex-curved safety glazing materials

Figure 4 — Impact points

9.2 Apparatus

9.2.1 Head-form weight, with a spherical or semi-spherical head made of laminated hard wood covered with replaceable felt and with or without a cross-beam made of wood. Between the spherical part and the cross-beam, there is a neck-shaped intermediate piece and on the other side of the cross-beam, a mounting rod.

The dimensions shall be in accordance with figure 5.

The total mass of the apparatus shall be $10 \text{ kg} \pm 0,2 \text{ kg}$.

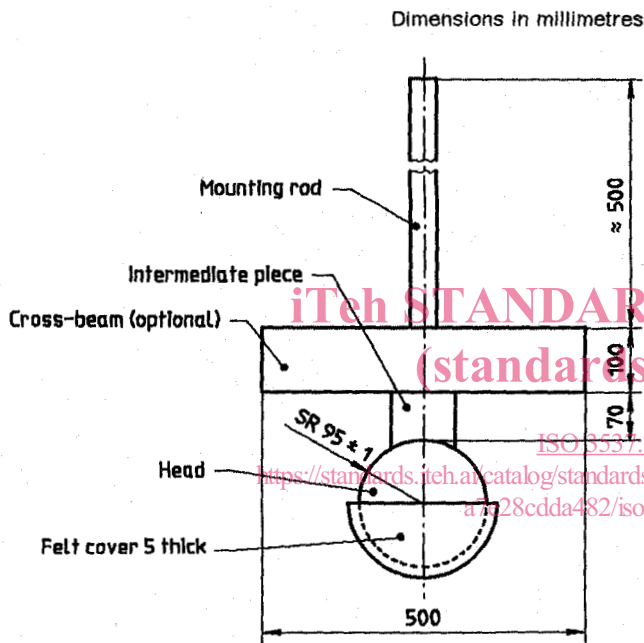

Figure 5 — Head-form weight

9.2.2 Means for dropping the head-form weight freely from a height to be specified, or means for giving the weight a velocity equivalent to that obtained by the free fall.

When a device to project the head-form weight is used, the tolerance on velocity shall be $\pm 1 \%$ of the velocity equivalent to that obtained by the free fall.

9.2.3 Supporting fixture, as shown in figure 6, for testing flat test pieces. The fixture is composed of two steel frames, with machined edges, 50 mm wide, fitting one over the other and faced with rubber gaskets about 3 mm thick, and $15 \text{ mm} \pm 1 \text{ mm}$ wide, of hardness 70 IRHD, measured in accordance with ISO 48.

The upper frame is pressed against the lower frame by at least eight bolts; the minimum recommended torque for M20 bolts is 30 N·m.

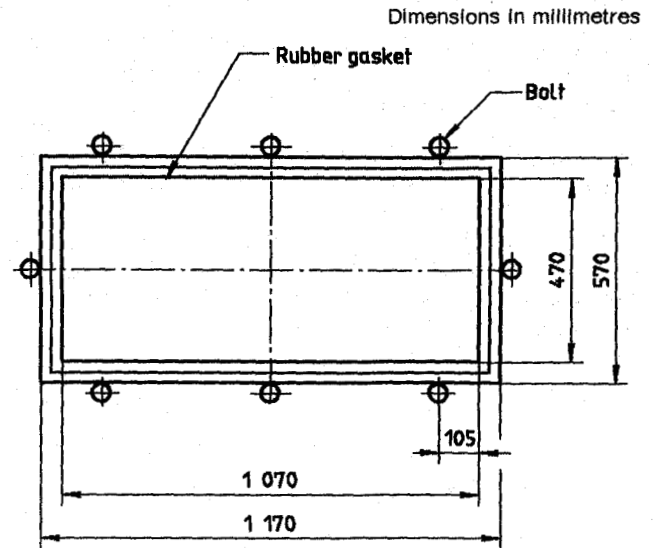

Figure 6 — Support for head-form tests

9.3 Procedure

9.3.1 Tests on flat test piece

The flat test piece, of length $1100 \text{ mm}^{+5}_{-2}$ mm and width 500 mm^{+5}_{-2} mm shall be kept at a constant temperature of $20 \text{ }^\circ\text{C} \pm 5 \text{ }^\circ\text{C}$ for at least 4 h immediately preceding the test.

Fix the test piece in the supporting fixture (9.2.3); the torque on the bolts shall ensure that the movement of the test piece during the test will not exceed 2 mm. The plane of the test piece shall be substantially perpendicular to the incident direction of the weight.

The weight shall strike the test piece within 40 mm of its centre on that face which represents the inside face of the safety glazing material when mounted on the vehicle, and shall be allowed to make only one impact.

The impact surface of the felt cover shall be replaced after 12 tests.

9.3.2 Tests on complete windscreen

These tests are used only for a drop less than or equal to 1,5 m.

Place the windscreen freely on a support shaped so that the head-form weight strikes that surface of the product which faces inward towards the passenger compartment when installed in the vehicle.